

**GENETIC STRUCTURE AND BIODEMOGRAPHY OF THE RAMA AMERINDIANS  
FROM THE SOUTHERN CARIBBEAN COAST OF NICARAGUA**

**By**

Copyright 2013

Norberto Francisco Baldi Salas

Submitted to the graduate degree program in Anthropology and the Graduate Faculty of the University of Kansas in partial fulfillment of the requirements for the degree of Doctor of Philosophy.

---

Dr. Michael H. Crawford (Chairperson)

Committee members:

---

Dr. Bartholomew C. Dean

---

Dr. Deborah Smith

---

Dr. John W. Hoopes

---

Dr. Brent E. Metz

Date defended: 4/5/2013

The Dissertation Committee for Norberto Francisco Baldi Salas certifies that this is the approved version of the following dissertation:

GENETIC STRUCTURE AND BIODEMOGRAPHY OF THE RAMA AMERINDIANS  
FROM THE SOUTHERN CARIBBEAN COAST OF NICARAGUA

---

Dr. Michael H. Crawford (Chairperson)

Date approved: 4/18/2013

## Abstract

This dissertation examines the evolutionary impact of recent historical events on the population structure of the Rama Amerindians who inhabit the southern Caribbean coast of Nicaragua, by analyzing the mitochondrial DNA (mtDNA) polymorphic variants and their biological relationship with, and ancestral divergence from other neighboring groups. Genetic profiles of 265 individuals from seven Rama communities revealed that the majority of individuals belong to haplogroup B2 (71%) or A2 (28%), with the remaining 1% of variation comprised by the maternal lineages C1 and L3. Based on multivariate analyses combined with median-joining networks, AMOVA, tests of selective neutrality and diversity, phylogeography, and surname isonymy analyses, it is proposed that the geographic distribution of the haplogroups among the Rama communities reflects the history of migration of this population after the European incursion into the Caribbean region of Southern Central America following the 16<sup>th</sup> century. Ethnographic and ethnohistorical accounts of sub-population fissions and subsequent forced migrations are congruent with these results, leading to the conclusion that the disruption of the Rama's traditional way of life led to changes in mortality patterns, reproductive dynamics and epidemiology, which ultimately impacted the genetic variation of this population.

Dedicated to my family and especially to my devoted mother Cecilia

## Acknowledgments

First of all I wish to thank my family for their love and support during my academic career, especially my brother Carlo Baldi and my mother Cecilia Salas, as well as Amy Quirin for her priceless help and kindness, and Joaquín Chaves for keeping me on track with his judicious advice

I would like to thank Dr. Michael H. Crawford for the guidance and support he has given me since the first day I knocked at his door. His opportune advice and knowledge have helped me to keep my academic spirit alive and to look to the future. I also extend my gratitude to my committee members: Dr Brent Metz, Dr. Deborah Smith, Dr. Bartholomew Dean, and Dr. John W. Hoopes for their counsel, teachings, and careful revision of this document. I am indebted to my academic colleague and collaborator Dr. Phillip Melton for his suggestions on this investigation, as well as to Dr. Ramiro Barrantes of the University of Costa Rica, and the researchers at the Laboratory of Biological Anthropology, particularly Orion Graf, Stephen Johnson, and Kristine Beaty. I would also like to thank Tiago Schaffrath for assisting me with the fieldwork in Nicaragua; his help was invaluable.

Thanks to the professors from the University of Costa Rica, Dr. Mauricio Murillo, Dr. Margarita Bolaños Arquín, Maureen Sánchez, M.A., Floria Arrea, M.A., for their support and friendship. I am especially grateful for the unconditional support of Dr. María Eugenia Bozzoli, whose passion for anthropology always has inspired me.

I would like to thank the Hoopes-Mattleman family for their kind support and for introducing me to the life and culture of the Midwestern United States. I am profoundly in debt to the Rama community in Nicaragua, especially to Mr. Cleveland, Lemon, and Jerry Macrea, as

well as Lorenzo Martinez for allowing me to explore their history and their land. Thanks to the epidemiologist Abraham Mayorga of MINSA for granting me access to primary demographic sources and to the Gobierno Regional Rama Kriol (GTR-K) for their interest and support of this investigation.

Lastly I wish to thank my close friends, whose enthusiasm, interest and support have given me the motivation to realize this achievement especially Shawn Maloney, Todd Rogers, Victor González, Amy Comfort, Dieter Schröder, Josu Galdos, Megan Migliazzo, Aida Ramos, and Luz Angelica Dean, and the Department of Anthropology office staff: Le-Thu Erazmus, Judy Ross, Carol Archinal, Kathleen Womack, and the department Chair Dr. Jane Gibson.

A scholarship from the office of International Affairs at the University of Costa Rica helped me to begin my academic journey to the United States. Additional financial support for this research came from the Tinker field research grant and the Charles Stansifer Fellowship awarded by the Center for Latin American Studies, the Summer Research Fellowship, and the Carroll D. Clark award from the Department of Anthropology of the University of Kansas.

# TABLE OF CONTENTS

<b>LIST OF FIGURES</b> .....	<b>x</b>
<b>LIST OF TABLES</b> .....	<b>xii</b>
<b>I-INTRODUCTION</b> .....	<b>1</b>
<b>II: POPULATION DYNAMICS OF SOUTHERN CENTRAL AMERICA</b> .....	<b>7</b>
<i>GEOLOGICAL AND ECOLOGICAL CONTEXT</i> .....	7
<i>THEORETICAL APPROACHES OF THE POPULATION DYNAMICS IN SCA</i> .....	9
<i>ARCHAEOLOGICAL DEMOGRAPHY OF SCA</i> .....	11
<i>MODELS OF THE PEOPLING OF SCA</i> .....	13
Human Colonization of the Caribbean Lowlands of Central America (11,000 - 5000 YBP).....	15
Archaeology of the Southern Caribbean Lowlands (4000-100 YBP).....	19
<i>DEMOGRAPHY AND RACIAL CLASSIFICATION IN THE 16TH CENTURY</i> .....	23
<i>ETHNO-LINGUISTIC DIFERENTATION IN SCA</i> .....	26
<i>NATIVE AMERICAN BIOLOGICAL VARIATION OF SCA</i> .....	29
Morphological-Classificatory Studies.....	30
Classical Polymorphisms and Microevolutionary Studies .....	32
Molecular Polymorphisms and Microevolutionary Studies .....	38
Pharmacogenetics.....	49
<i>SUMMARY</i> .....	52
<b>III- THE RAMA AMERINDIANS</b> .....	<b>54</b>
<i>SOCIO-CULTURAL AND DEMOGRAPHIC CHANGE</i> .....	55
European Influence in the Nicaraguan Mosquitia (16 <sup>th</sup> - 19 <sup>th</sup> centuries) .....	56
The Moravian Missionaries.....	58
Market Economy of the 20 <sup>th</sup> Century and Expansion of the Agricultural Frontier .....	59
<i>RAMA ORIGINS AND CULTURAL NICHE</i> .....	60
Origin of the Rama .....	60
Residence Relocation and Demography.....	63
Social Structure .....	65
Origin of the Rama Surnames .....	68
Language and Cosmography .....	69
Niche Construction and Means of Subsistence .....	71
Present-day Rama Communities .....	74
<i>SUMMARY</i> .....	78
<b>IV- MATERIALS AND METHODS</b> .....	<b>79</b>
<i>SAMPLE COLLECTION</i> .....	79
Participant Demographic Questionnaire .....	81

<i>DEMOGRAPHIC PROFILE</i> .....	82
Demographic Structure and Population Composition .....	82
Vital Statistics .....	83
Death Rates .....	83
Fertility Rates .....	85
Effective Population Size .....	87
Opportunity for Natural Selection .....	87
Population Change .....	89
Time Series Analysis.....	89
<i>SURNAME ANALYSIS BASED ON ISONYMY</i> .....	93
Genealogical Reconstructions .....	94
Migration, Kinship Networks, and Mate Choice Behaviors .....	94
Surname Distribution .....	95
Surname Variation within Subpopulations.....	96
Surname Variation between Subpopulations .....	98
Population Substructure (subdivision) .....	99
Consanguinity Estimates .....	100
Isolation by Distance.....	101
<i>DNA AND BLOOD GROUP POLYMORPHISM ANALYSIS</i> .....	103
DNA Extraction.....	103
mtDNA HVS-I Sequencing.....	104
RFLP and Haplogroup Testing .....	106
Classical Genetic Polymorphisms .....	107
<i>GENETIC ANALYTIC PROCEDURES</i> .....	108
Intrapopulation Variation .....	108
Interpopulation Variation .....	114
Chronometric Techniques .....	118
<i>SUMMARY</i> .....	120
<b>V- RESULTS</b> .....	<b>122</b>
<i>DEMOGRAPHIC PROFILE</i> .....	122
Age and Sex Structure.....	122
Population Change .....	125
Total Fertility and Reproductive Health.....	126
Specific and Crude Mortality and Fertility Rates.....	130
Effective Population Size ( $N_e$ ).....	133
Opportunity for Natural Selection.....	133
Health and Disease among the Rama .....	135
Age and Sex Structure at the Southern Atlantic Autonomous Region (RAAS) .....	138
Disease Prevalence at RAAS .....	140
Vector-borne Diseases at RAAS .....	142
Causes of Death at RAAS .....	143
Time Series Analysis on Mortality.....	145
ARIMA Time Series Model.....	148
<i>SURNAME ISONYMY</i> .....	151
Surname Distributions.....	151
Marital Migration and Mate Choice.....	154



Exogamic Relationships.....	157
Intra Population Variation.....	160
Inter Population Variation.....	161
Biodemographic Structure.....	166
Isolation by Distance.....	169
<b><i>GENETIC STRUCTURE OF THE RAMA</i></b> .....	<b>172</b>
Restriction Fragment Length Polymorphisms (RFLPs) and Haplogroup Characterization.....	172
HVS-I Sequencing.....	177
Haplotype Network and Chronometry.....	180
Multidimensional Scaling Plot.....	184
<i>R</i> -Matrix.....	185
Genetic Diversity and Neutrality Tests among Six Rama Subpopulations.....	186
Mismatch Distribution.....	187
Genetic Barriers and Phylogeographic Analysis.....	191
Analysis of Molecular Variance (AMOVA).....	193
<b><i>REGIONAL GENETIC STRUCTURE</i></b> .....	<b>195</b>
Gene Diversity and Neutrality Tests for Comparative Populations.....	196
Multidimensional Scaling (MDS) and <i>R</i> -matrix analyses.....	199
Heterozygosity Versus <i>rii</i> .....	203
Median Joining Networks.....	206
Regional Barriers of Gene Flow.....	213
Regional Genetic Structure Based on AMOVA.....	215
Genetic Chronometry.....	217
<b><i>SUMMARY</i></b> .....	<b>218</b>
<b>VI – DISCUSSION</b> .....	<b>220</b>
<b><i>GENETIC RELATIONS AND ETHNOGENESIS OF THE RAMA AMERINDIANS</i></b> .....	<b>220</b>
Mitochondrial Diversity.....	220
Regional Genetic Geography.....	225
<b><i>GENETIC STRUCTURE AND FORCES OF EVOLUTION</i></b> .....	<b>232</b>
<b><i>EVOLUTIONARY CONSEQUENCES OF RECENT HISTORICAL EVENTS</i></b> .....	<b>234</b>
Genetic Architecture of the Rama.....	234
Kin Structure Migration and Historical Origins of the Rama.....	240
Transition and Contemporary Dynamics of Kin Structure Migration.....	246
<b><i>CULTURAL AND ENVIRONMENTAL EFFECTS ON DEMOGRAPHIC STRUCTURE</i></b> .....	<b>247</b>
<b><i>SUMMARY</i></b> .....	<b>252</b>
<b>VII – CONCLUSION</b> .....	<b>253</b>
<b>BIBLIOGRAPHY</b> .....	<b>257</b>
<b>APPENDIXES</b> .....	<b>284-291</b>

## LIST OF FIGURES

Figure 1. Southern Central America (SCA) and contemporary Rama Amerindian territory.....	2
Figure 2. Geographic location of selected archaeological sites of SCA .....	17
Figure 3. Existing ethno-linguistic populations from SCA.....	28
Figure 4. Linguistic coalescence of Macro-Chibchan languages.....	29
Figure 5. Antropometric studies among Indigenous populations from Nicaragua .....	31
Figure 6. Minimum string network showing genetic relationships.....	35
Figure 7. Phylogenetic tree showing the ancient Chibchan divergence.....	37
Figure 8. Physical map of the mtDNA molecule .....	40
Figure 9. Time chart of biological and associated historical events .....	51
Figure 10. Rama territory and visited communities during fieldwork (2007/2009). .....	55
Figure 11. Kinship representation of a local group after fission.....	67
Figure 12. Annual rainfall in the southern Caribbean region of Nicaragua (2008) .....	72
Figure 13. Age-group distribution of Rama and Creole populations.....	124
Figure 14. Rama population pyramid (2005).....	125
Figure 15. Maternal care at Rama Cay .....	128
Figure 16. Diseases consulted in the clinic at Rama Cay and the <i>comarca</i> (1996-2005).....	136
Figure 17. Number of deaths according with the Moravian Church.....	138
Figure 18. RAAS Population pyramid (2012) .....	139
Figure 19. Prevalence of acute infections in the southern Caribbean region of Nicaragua .....	140
Figure 20. Less frequent injuries and maladies at RAAS. ....	141
Figure 21. Less frequent and new illness at RAAS. ....	142
Figure 22. Diagnosed cases of vector-borne diseases at RAAS. ....	143
Figure 23. Death rates at the southern Caribbean Nicaragua (RAAS).....	144
Figure 24. Less frequent causes of death (RAAS).....	145
Figure 25. Logarithmic transformation of population agregations. ....	146
Figure 26. Cross-correlations of mortality data .....	147
Figure 27. ACF for mortality records. Lines are between 5% confidence limits. ....	148
Figure 28. Secular trend of mortality and ARIMA .....	150
Figure 29. Ratios of premarital residence. ....	155
Figure 30. Neighbor Join tree of internal migration in the Rama territory .....	157
Figure 31. MDS of kinship networks.....	159
Figure 32. Isonymy values of seven Rama localities.....	160
Figure 33. MDS of Lasker's $R_i$ values .....	162
Figure 34. Map of Lasker's coefficient of Relationships ( $R_{ib}$ ).....	164
Figure 35. MDS of <i>a-priori</i> kinship between Rama subpopulations ( $\Phi_{ij}$ ).....	165
Figure 36. MDS coefficient of kinship ( $I_{ij}$ ) and unbiased Isonymy ( $I_{ii}$ ).....	165
Figure 37. Trends in $RP$ , $RP_r$ , and $RP-RP_r$ values. ....	168
Figure 38. Map of the geographical positions generated by MDS .....	170
Figure 39. 3-D MDS of Lasker's $D$ showing kinship relationships based on isonymy .....	171
Figure 40. MDS of Euclidian distances between Rama communities. ....	172
Figure 41. Median joining phylogenetic network of six Rama populations .....	182
Figure 42. MDS plot of mtDNA HVS-I pairwise genetic differences.....	184
Figure 43. PCA of the $R$ -matrix of the Rama subpopulations using mtDNA HVS-I. ....	185
Figure 44. Mismatch distribution for the Rama .....	189
Figure 45. Mismatch distribution for six Rama subpopulations. ....	191

Figure 46. Delaunay triangulation based on the Monmonier's algorithm..	192
Figure 47. Interpolated genetic landscape of six Rama localities.	193
Figure 48. MDS of mtDNA genetic distances among comparative populations.	200
Figure 49 MDS of nine Chibchan populations and one Oto-Manguean (Chorotega)	201
Figure 50. PCA of the $R$ -matrix of 24 comparative populations	202
Figure 51. Regression plot of heterozygosity values and distance from the centroid ( $r_{ii}$ )	206
Figure 52. Median Joining network for haplogroup A2 and associated linguistic groups.	207
Figure 53. Reduced median network of Haplogroup A2 and associated linguistic families.	208
Figure 54. Median joined network of haplogroup B2 and associated linguistic families.	210
Figure 55. Phylogenetic network of associated B2 haplotypes from Central and SA	211
Figure 56. Reduced median network of Haplogroup C1 and associated linguistic families.	212
Figure 57. Delaunay triangulation	214
Figure 58. Heuristic model based on the coalescence on mtDNA and historical linguistics.	231
Figure 59. Rama family members traveling by canoe ( <i>dori</i> )	239
Figure 60. Migratory history of the Rama (Voto)	245

## LIST OF TABLES

Table 1. Population estimates from different regions in pre-Hispanic Panama.....	12
Table 2. Population estimates at the beginning of the sixteenth century in CA. ....	25
Table 3. Mutations found in Chibchan speaking populations from SCA .....	37
Table 4. Documented population figures of the Rama .....	64
Table 5. Cosmography of the Rama.....	70
Table 6. Some hunted and gathered resources observed during fieldwork (2008/2009).....	74
Table 7. Study populations of six Rama communities.....	80
Table 8. Haplogroup and HVS-I associated sequences, primers, and annealing temperatures .....	105
Table 9. Population census according with the GTR-K (2005-2007).....	123
Table 10. Population change for RAAS and the <i>comarca</i> of Rama Cay between 2002 and 2007. ....	126
Table 11. General and specific fertility rates computed before 2008 .....	127
Table 12. Maternal health, children birth and mortality (2007-2008). ....	128
Table 13. Pregnancy records from the Rama Cay clinic, period 1997-2008. ....	129
Table 14. Regional maternal, fetal, and neonatal mortality rates (RAAS). ....	130
Table 15. Age structure and death rates of the <i>comarca</i> of Rama Cay.....	132
Table 16. Caused specific death ratios at the <i>municipio</i> , and the <i>comarca</i> of Rama Cay.....	132
Table 17. Death records according with the Moravian Church and the clinic at Rama Cay. ....	133
Table 18. Crow's indices. ....	134
Table 19. Rates of diseases at the clinic and the <i>comarca</i> of Rama Cay .....	135
Table 20. Analysis of variance and regression diagnostics.....	146
Table 21. Less frequent surnames in Rama communities.....	152
Table 22. Top thirty more frequent surnames in seven Rama communities.....	153
Table 23. Geographic positions and marital distances.....	154
Table 24. Migration Matrix for Rama subpopulations.....	156
Table 25. Exogamic relationships within Rama communities.....	158
Table 26. Probability matrix of kinship network between Rama communities.....	159
Table 27. Isonymy analysis of 7 Rama localities.....	161
Table 28. Matrix of coefficients of Lasker's relationships by Isonymy <i>Ri</i> .....	163
Table 29. Matrix of Lasker's coefficient of relationships between communities <i>Rib</i> .....	163
Table 30. Values of consanguinity and repeated pairs of seven Rama communities .....	167
Table 31. Mantel correlations .....	169
Table 32. Percentages of haplogroups among Rama subpopulations. ....	174
Table 33. Native American haplogroup frequencies of 33 comparative populations.....	176
Table 34. mtDNA sequences for six Rama subpopulations.....	179
Table 35. Most frequent satellite nodes among Rama communities.....	183
Table 36. Diversity and neutrality tests among Rama subpopulations .....	187
Table 37. Time estimates and neutrality test values for haplogroups A2 and B2.....	190
Table 38. AMOVA between all Rama subpopulations.....	194
Table 39. AMOVA for Rama subpopulations based on three geographic groupings.....	194
Table 40. AMOVA based on central and peripheral groups.....	195
Table 41. Diversity values and neutrality tests of 24 selected populations.....	198
Table 42. Allelic frequencies from segregating classical polymorphisms.....	204
Table 43. Haplogroup A2 and associated nodes .....	209
Table 44. Haplogroup C1 and associated nodes .....	213
Table 45. AMOVA based on geographical grouping .....	216

Table 46. AMOVA based on linguistic affiliation.....	216
Table 47. AMOVA based on four major cultural areas .....	217
Table 48. Time estimates for Chibchan populations.....	218

## I-INTRODUCTION

*“Men make their own history, but they do not make it as they please. They do not make it under self selected circumstances, but under circumstances existing already, given and transmitted from the past” (Karl Marx. Eighteenth Brumaire of Louis Bonaparte)*

The isthmus of Central America is an area of great anthropological significance because it enabled initial Amerind migration from North to South America as well as the settlement and microevolution of local indigenous populations. The fields of anthropological genetics, historical linguistics, and archaeology agree that long term isolation of this region shaped a particular sociocultural trajectory and population structure. However, integration of the extinct and extant Caribbean Amerindian groups within this framework of reference is incomplete and deserves more attention (Barrantes et al. 1990; Batista et al. 1998; Batista et al. 1995; Bieber et al. 1996; Constenla 1995; Constenla 2002a; Cooke and Ranere 1992a; Fonseca 1997b; Hoopes and Fonseca 2003; Kolman et al. 1995; Melton 2008). This study attempts to enhance biocultural studies of this region by characterizing the genetic history and the interplay of historical events on the population structure of the Rama, an indigenous group inhabiting the southern Caribbean coast and lowlands of eastern Nicaragua (Fig.1). This project builds on previous research in Southern Central America (SCA) (e.g., Barrantes et al. 1990; Batista et al. 1998; Bieber et al. 1996; Melton et al. 2010; Melton et al. 2007) and provides additional inferences on the population dynamics of the Rama within broad human geographical areas of Mesoamerica, the Caribbean, and Central and South America.

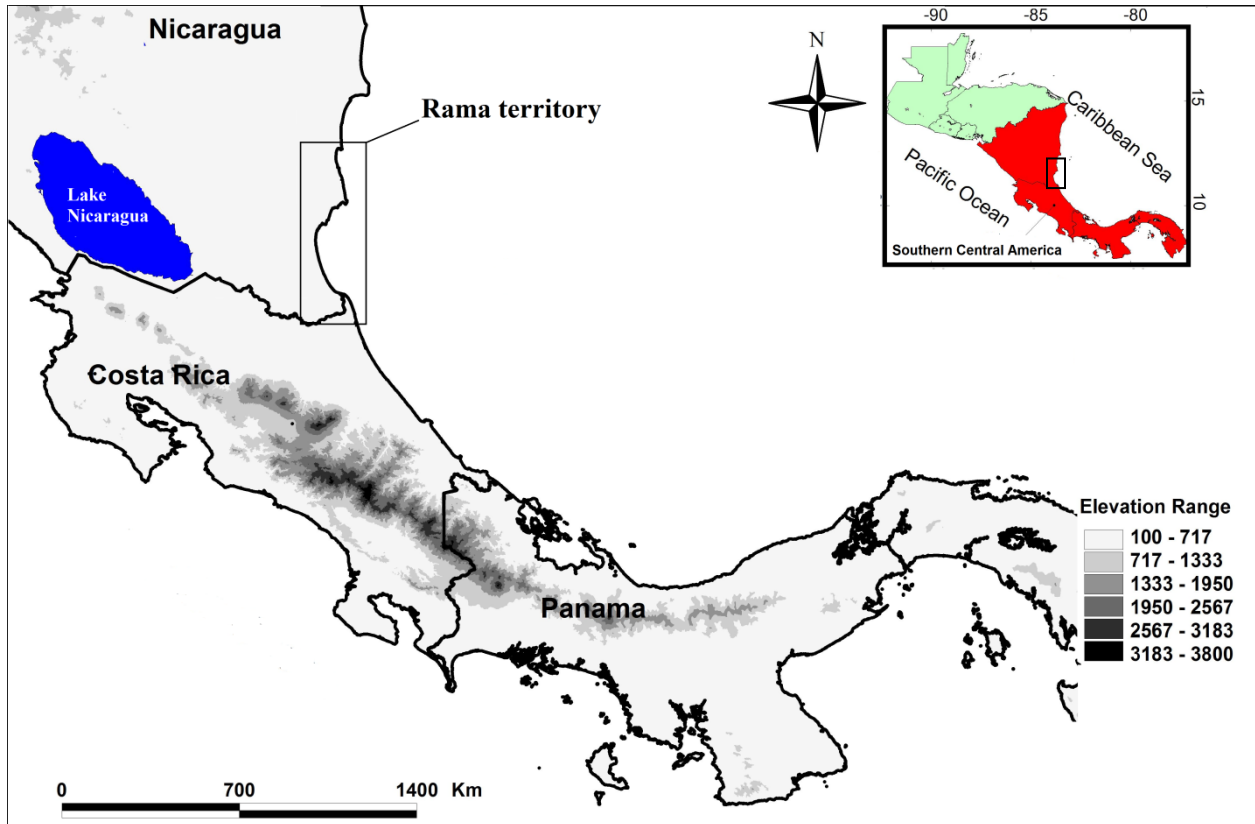

Figure 1. Southern Central America (SCA) and contemporary Rama Amerindian territory.

Beginning in the 16<sup>th</sup> century, Amerindian populations of SCA were described by explorers and settlers in accordance with European standards of the time. Interest in the human and cultural diversity of SCA indigenous groups intensified in the 19<sup>th</sup> century as a result of the application of scientific methodology; however, the study of demographic processes of pre-Columbian, colonial and post-colonial periods was centered on the Pacific side of SCA rather than on the Caribbean. Historical information about the west coast was readily available due to centuries of colonial control of native populations there, whereas on the Caribbean side,

torrential rainfall and vast wetlands retarded the European influx until the late 17<sup>th</sup> century (Romero 1995).

The relative isolation and the limited economic development of the Caribbean coast have been partially responsible for the slow advancement of anthropological studies in the area (Cooke 2005; Fonseca 1987; Lange 1984). While the Pacific and central highlands of SCA have been continually studied, in the Caribbean region, culture and demography have been reconstructed based mostly on a few ethnohistorical, bioanthropological, and archaeological studies (Conzemius 1938; De Stefano 1973; Drolet 1980; Gassiot and Estévez 2004; Helms 1969; Ibarra 2011a; Linares and Ranere 1980; Magnus 1974; Offen 1999; Offen 2002; Romero 1995; Smutko 1988; Snarskis 1992; Steward and Faron 1959; Stone 1966; West 1964). The vast majority of these approaches assume that environmental conditions in the Caribbean lowlands resulted in a low level of cultural development and that the area was instead populated or heavily influenced by waves of migrants from other regions. There is also an assumption that its cultures passed or fail to pass through similar phases of cultural evolution. Cross-cultural generalizations based on deductive models and recent “interpretative perspectives” fail to explain the internal dynamics of this region, perpetuating a misleading image of the role that culture and the environment play in molding evolutionary processes and constructed niches.

The scant bioanthropological research on contemporary indigenous groups from the Caribbean region of SCA demonstrates a limited understanding of intergroup relationships and genetic history. In addition, most recent molecular research highlights the effects of migration on vast continental regions rather than assessing population dynamics of individual groups that occupy their own changing niches. In SCA, few studies have focused on the microevolutionary consequences of cultural practices or the recent effects of historical events such as migration and



the selective forces that operate on the structure of small, isolated groups (Barrantes 1993; Barrantes et al. 1982).

The origin and history of migration of the Rama remain unresolved. Some hypotheses propose that the Rama are the remnant of the Votos who were reported to inhabit the lowlands of northern Costa Rica and Rio San Juan in the 16th century. Others propose their amalgamation with a number of other groups that were blended after the European incursion into the Caribbean (Riverstone 2004). Despite unresolved issues about their origin, they have been recognized as a culturally (Conzemius 1930; Loveland 1975), linguistically (Constenla 2008; Craig 1990), and biologically unique population among other Caribbean populations in Nicaragua (D'Aloja 1939; De Stefano 1973; Schultz 1926). Recent studies in anthropological genetics and historical linguistics suggest the Rama are related to other Chibchan speakers from SCA and northern South America (Constenla 2008; Melton et al. 2013), and were significantly impacted by gene flow from Europeans and neighboring Mesoamerican indigenous populations (Melton et al. 2013). These investigations, however, have not integrated factors that disrupted the traditional Rama way of life, social organization, and demographic events that sculpted the genetic structure of this group.

Distinctive genetic information has permitted exploration of the expected level of differentiation due to historical, political, and economic forces that had an impact upon the Rama's traditional ways of living, social organization, marital practices, and settlement patterns since European contact. This was accomplished by studying the population structure and their two interrelated components: demographic structure and genetic structure. Demographic structure consists of the associated processes of birth, death, and migration, and includes the mating system and life history of a population. Genetic structure is the observable difference in

gene frequency distributions resulting from previous human demographic events such as geographical isolation, cultural dynamics, and changes in a population's environment that affect mate choice (Crawford 2001; Donnelly and Foley 2001; Steele and Shennan 2009). Some of these factors can only be assessed by providing an anthropological context for the sample, that is, a geographic location along with ethnographic and bio-demographic information. By combining this demographic information with mitochondrial DNA (mtDNA), the probability of past demographic events can be modeled and the relationship between pairs populations established along with the levels of historical concordance with archeological, ethnohistorical, and linguistic events (Donnelly and Foley 2001; Weiss 1998).

The primary goals of this dissertation are to establish the biological relationship between the Rama and regional extant Amerindian populations and to explore the role of coastal populations in the peopling of SCA. This project expands the understanding the evolutionary history of the Rama while investigating the following questions:

1. What does genetic variation from mtDNA reveal about the population history of the Rama in a broad context of regional human geography?
2. What forces of evolution are impacting the Rama?
3. What is the relative influence of recent historical events on their population structure?
4. What are the consequences of cultural practices and the environment on the biodemography of the Rama?
5. Is there any correspondence among genetic, archeological, ethnohistorical, and linguistic events and the history of the Rama?

In this investigation, mtDNA polymorphic variants were used to examine the maternal genetic structure of the Rama, their biological relationship with, and their ancestral divergence from other neighboring groups. Blood protein markers were obtained from literature in order to

approximate bi-parental genetic transmission. Parental surnames taken from genealogies provided supplemental information on recent mating behaviors and allelic patterns of inheritance (Sanna et al. 2006). In addition, demographic information was collected during fieldwork and from official data sources.

This dissertation is subdivided into seven chapters. Chapter two describes the geographical context of SCA, emphasizing the Caribbean region and providing the reader with the contributions of different historical, archeological, linguistic, and ethnological disciplines relevant for the reconstruction of the demography, migration, and colonization of the Caribbean in pre-Columbian times and on the eve of the Spanish conquest. This chapter also presents a detailed historical review of the state of biological anthropological research in SCA since the beginning of the 20<sup>th</sup> century. Chapter three describes the ethnohistorical and ethnographical background of the Rama together with recent sociocultural and demographic changes in order to evaluate the effects of historical events on the Rama culture and genetic structure. Chapter four describes fieldwork and data collection methods, as well as methods for intra- and interpopulation analysis and construction of a biodemographic profile. Chapter five discusses the relevant results of this investigation, chapter six discusses the results, and chapter seven concludes and briefly addresses the implications of this research on future studies on the population dynamics studies in Central America.

## **II: POPULATION DYNAMICS OF SOUTHERN CENTRAL AMERICA**

This chapter is divided into three sections that contextualize demographic events that have shaped the genetic architecture of the Rama Amerindians and other contemporaneous indigenous populations of the Caribbean coast of Southern Central America: the first section provides a general geographic context of SCA with emphasis on the Caribbean lowlands and coast; the second, an historical overview of the demographic studies in SCA based on historical, archeological, and theoretical contributions; and the third, reviews the biological anthropological studies in SCA within historical context.

### ***GEOLOGICAL AND ECOLOGICAL CONTEXT***

Geologically, SCA emerged as a continental terrain through subduction, volcanism and sedimentary events between 3 and 6 million years ago (MYA). The formation of this landmass had important implications for biogeography, oceanography and the migration of humans and animals, and for the colonization of plants from North and South America (Barker 2007; Weir et al. 2009 ). In turn, the central volcanic spine, the major geographical feature dividing the Pacific and Caribbean regions, functioned as a barrier for marine species and isolated human populations, animals, and plants (Barrantes et al. 1990; Coates et al. 2003; Cooke 2005; Cropp and Boinski 2000; Janzen 1983; Rains 1997).

The separation of the Caribbean Sea and the Pacific Ocean by the Central American Isthmus is also responsible for differences in climate and marine ecology. In the Pacific, currents created by the northeast trade winds cause the rise of rich nutrients from the bottom waters and contribute to changes in rainfall, sea temperatures, biological productivity and seasonality.

Additionally, the sporadic upwelling of nutrients caused by ENSO (El Niño Southern Oscillation) (Jackson and D'Croz 1997; Rains 1997) sustained pre-Columbian populations from Panama's Pacific coast since 7000 YBP, making it one of the most studied areas in SCA (Cooke and Sanchez 2001).

In contrast, the Caribbean Sea is more stable in terms of its oceanography, climate, water movement, biological production (biodiversity), and construction (the assembly of biological structures). The Caribbean coasts of Costa Rica, Panama, Nicaragua and Honduras are dominated by coral reefs, mangrove swamps, inundated forests, and sea grass beds. From the Mosquitia region of the Nicaraguan coast to Panama, large rivers flow into swampy estuaries, and marsh and fresh water lagoons are interconnected by meandering coastal channels. Extensions of sea grass beds (*Thalassia sp.*) and coral reefs are critical spaces of marine biodiversity and are economically significant for contemporary coastal populations (Jackson and D'Croz 1997; Rains 1997).

Most of the Caribbean coast of SCA, including the Mosquitia in Nicaragua, Costa Rica, and Panama, were formed by marine sediments, some patches of volcanic rocks, and old subduction zones in north-eastern Panama. Geomorphically, the southern Caribbean coast of Central America incorporates Caribbean Honduras and the Mosquitia of Nicaragua; it is extended for 1000 km along the coast and lowlands in a swath 150 km wide (Maldonado-Koerdell 1964). The lowlands of the Talamanca Massif in Costa Rica and western Panama, as well as the Canal zone and Darien are also part of the Caribbean region of Central America (Rains 1997). Precipitation measures between 1600 and 7000 ml per year and most of the region is characterized by excessive humidity and water logged soils distributed in tropical and subtropical life zones (Hall and Perez-Brignoli 2003).

Sediment cores extracted from lakes in the Caribbean lowlands of Petén and Panama showed different paleo-ecological histories. Pollen, carbon particles, clay minerals and phytoliths indicate a long term change in the local ecology. According to this record, temperatures were cooler in glacial times by approximately 6 degrees (°C). With the transition to the Holocene and the increase of temperatures, the savanna-like region of the Petén was transformed into a tropical forest, whereas in lowland Panama, the evergreen forest of the Pleistocene endured through the transition to the Holocene with only minor changes (Colinvaux 1997; Colinvaux et al. 1996; Piperno and Pearsall 1998).

In terms of geology, ecology, and climate, the Pacific coast and the Caribbean coast have evolved differentially. The differences in environments and ecologies may have had important consequences for human niche constructions, demography, social organization, and biological evolution. However, the importance of the environmental uniqueness of the Caribbean region compared with the Pacific side deserves attention here and in future anthropological studies.

### ***THEORETICAL APPROACHES OF THE POPULATION DYNAMICS IN SCA***

In the absence of population estimates before and after the Spanish conquest, the evolutionist and diffusionist models were applied to approximate demography and estimate population dynamics and social change in SCA. Evolutionary models assume that societies evolve in a linear fashion and are based on predetermined cultural types —band, tribe, chiefdom, state— (Service 1962). Diffusionist models propose that the causes of social evolution were migrations and the circulation of ideas from more advanced innovation centers to the peripheries (Meggers 1998). Depending on the authors and their perspectives, these paradigms were

interrelated to a greater or lesser degree (Baudez 1970; Coe 1960; Haberland 1981; Snarskis 1992; Spinden 1917; Stone 1984).

The combination of diffusionist and evolutionist principles were used for interpreting social change and demographic processes that occurred in pre-Columbian SCA and the Central American Caribbean (Baldi 2010). External cultural influences and successive migrations were the most recurrent explanations for the apparent similarities of cultural, linguistic and physical characteristics among indigenous groups in SCA. Voyages of exploration to Central America undertaken by scholars and adventurers at the end of 19<sup>th</sup> century contributed to the spread of this idea (Stone 1984), a notion based on 16th century chroniclers such as Juan de Torquemada, who proposed that indigenous populations from southwest Nicaragua and the province of Guanacaste in Costa Rica (Gran Nicoya) were remnants of Mesoamerican migrations from Mexico (Torquemada 1975 [1615]). Furthermore, at the beginning of the 20th century, art historian Walter Lehmann proposed the similarity of Central American ceramic designs to those of Mesoamerica and South America (Lehmann 1920), and anthropologist J. H. Spinden divided a great part of Central America into cultural provinces based on such influences (Spinden 1917). Likewise, in recent decades influential archeologists such as Claude Baudez adopted the diffusionist paradigm to explain the Mesoamerican cultural and linguistic influence in the Gran Nicoya region (Baudez 1970).

On the other hand, cultural ecology, a predominant perspective in the mid-20th century, was the basis for a proposal that population density and social organization could be deduced from the geographical circumscription of populations (Baker and Sanders 1972; Steward 1948; Steward and Faron 1959). The Central American chiefdoms are used as an example of this

phenomenon because is a type of social organization that precede the statal organization according with this notion of cultural evolution (Steward 1948; Willey 1971).

After the nineteen-eighties, studies of population dynamics of SCA societies emphasized their endogenous development (Fonseca 1989; Fonseca and Cooke 1993). From this viewpoint, diffusion is thought to have transpired within the regional boundaries of the Isthmo-Colombian area, between eastern Honduras and Lake Maracaibo in Venezuela (Cooke 2005; Hoopes and Fonseca 2003). This area was defined on the basis of long-term social and biological affinity from Paleo-Indian times by reference to genetic descent and the linguistic coalescence of Chibchan speakers.

### ***ARCHAEOLOGICAL DEMOGRAPHY OF SCA***

In anthropology, demography is defined as the study of changes in the number of individuals in a population and the relationship between mortality, growth rate and age structure (Macbeth and Collinson 2002). Similarly, archeological demography investigates the structure and dynamics of past human populations using information provided by the traces of ancient human activities and remnants of material culture. Archaeological demography, despite not being fully developed in SCA, is one focus for studies on population dynamics, and it serves as a contextual background of the evolutionary factors that shape the genetic profiles of contemporary human populations.

In archeology, different types of data serve as proxies of ancient population distribution and density. This includes artifacts, sites and paleoenvironmental information, buried human remains and mortality patterns. Demography can be reconstructed by combining these sources of information (Chamberlain 2009; Drennan et al. 2003). In the archeology of SCA, the few



existing demographic studies have gravitated towards socio-political organization and social ranking themes (Cooke and Ranere 1984; Cooke and Ranere 1992a; Linares and Ranere 1980; Linares and Sheets 1980; Snarskis 1978; Snarskis 1992). Less frequently, investigations have attempted to reconstruct relative and absolute population numbers. Among the most important of these studies are concerned with the Barú Volcano region, of Western Panama (Linares and Sheets 1980), and the Central Pacific region of Panama (Cooke and Sánchez 2004; Hansell 1988) (Table 1).

Table 1. Population estimates from different regions in pre-Hispanic Panama (1400-400 YBP).

Site	Region/Period	Reference	Regional population (ind.)
Pitti-Gonzalez	Western Panama/ 1400 YBP	(Linares and Sheets 1980)	2,432
La Mula-Sarigua	Central Pacific/ 2200 - 1750 YBP	(Hansell 1988)	693-1,820
Escoria's sites	Central Pacific/ 1300 - 448 YBP	(Cooke and Sánchez 2004)	7,800

In Nicaragua, Salgado (1996), proposed a population explosion after 300 CE in the Southern Pacific region and calculated the number of inhabitants of the Sapoa phase (800-1350 CE) based on 16<sup>th</sup> century documentation and associated surface features and ceramics from archeological sites (Salgado 1996: 108; Salgado et al. 2007). More recent approaches have used mathematical modeling for inferring demographic sizes and other social variables in Costa Rica and Panama (Haller 2004; Menzies 2009; Murillo 2009; Palumbo 2009).

Skeletal material is another useful tool for identifying patterns of gene flow, genetic drift, and spatial structuring of populations (Fuselli et al. 2003; Pucciarelli et al. 2008; Pucciarelli et al. 2006). In a recent study by Pucciarelli, et al. (2008), human skulls from the Costa Rican Pacific and Honduras (700 – 600 YBP) were used for morphological comparisons in order to assess ancient migratory patterns in the Americas. However, skeletal material has not been used to assess other demographic aspects among pre-Columbian SCA populations. One important reason for this omission may be their poor preservation of osseous materials in tropical environments (Fonseca 1992; Sheets and McKee 1994). Therefore, the infrequent occurrence of this type of remains is a limiting factor while attempting regional bio-archeological research (Nagy 2008).

Osteological studies in Costa Rica and Panama have used isotope analysis to identify subsistence strategies as well as paleopathologies and their basic demographic profile —age and sex— (e.g., Briggs 1989; Diaz 1999; Hardy 1992; Nagy 2008; Norr 1991; Obando 1995; Vasquez 1984; Vasquez and Weaver 1980). Additionally, osteological evidence from mortuary contexts has allowed archeologists to infer aspects related to pre-Columbian wealth, social status, and the emergence of social ranking (Briggs 1989; Cooke et al. 2000; Lothrop 1937; Lothrop 1942).

### ***MODELS OF THE PEOPLING OF SCA***

In SCA, the Holocene epoch (~10,000 YBP) was accompanied by the transition of the hunting and gathering way of life to agriculture and sedentarism. This transition led to changes in social organization and diets, as well as to exploration and adaptation to new geographical areas. In order to understand the most plausible scenario of human adaptation to the emerging tropical conditions between the late Pleistocene (~12,000 - 10,000 YBP) and the early Holocene

(~10,000 - 5,000 YBP) in SCA, Piperno and colleagues have proposed a model based on the optimal foraging theory (Piperno 2006a; Piperno 2011; Piperno and Jones 2003; Piperno and Pearsall 1998). This model states that in the late Pleistocene, populations that inhabited the Pacific region of SCA took advantage of high ranked resources such as ground sloths (*Eremotherium*), giant capybaras (*Hydrochoerus*), toxodons (*Mixotoxodon*), mastodons (*Cuvieronius*), and others. This hypothesis states that a decline in the abundance of big game caused by environmental changes at the transition to the Holocene (Colinvaux 1997; Colinvaux et al. 1996; Webb et al. 1997) lead to the exploitation of lower ranked foods like small mammals and plants by the local populations on the Pacific, contributing to the development of agrilocality. In addition, this dietary switch opened the possibility for a more diverse diet that compensated for the decreased availability of animal protein previously obtained from large game. Dense and resilient foods such as tubers and roots common in the Pacific watershed allowed foragers increase their residence stability and their investment in storage and food processing, ultimately leading to an increase in population numbers (Piperno and Pearsall 1998).

The transition from moister forests to modern ever-wet tropical evergreen forests in the Caribbean was less dramatic than the Pacific side in terms of changes in precipitation, animal extinctions, and seasonality, causing little interference with the distribution and abundance of resources with potential profitability for humans. Furthermore, in this region, animals tended to be small, mostly arboreal, and lower in biomass. Potential edible plants were dispersed and low in calories. In accordance with this model, the “less favorable habitats” of the Caribbean made that area a less likely stage for the development of agriculture, which instead diffused from the Pacific region after its development there (Piperno 2006a; Piperno and Jones 2003; Piperno and Pearsall 1998).

This application of the optimal foraging theory is the most accepted hypothesis to date, since the preponderance of archaeological evidence has been gleaned from the Central Pacific region of Panama (Cooke and Ranere 1992b). Nevertheless, it should be taken into account that archaeological research has been recently developed in the Caribbean, allowing for the future possibility of locating more late Pleistocene and early Holocene sites there. As an alternative hypothesis, it may be proposed that the foraging economy was more diverse and widespread in different ecological zones than previously assumed. Hunter-gather populations that exploited a broad spectrum of resources from diverse environments including mountainous areas, forest, and coasts are thought to be less sensitive to climatic perturbations than those that are dependent on few or local resources (Messenger 1991). Some evidence exists to provide support for an early manipulation of forest environments in Panama, Venezuela, Colombia, Brazil, and Costa Rica. For example, early lithic techno-complexes have been located in different lowland areas in South America. This evidence, together with paleo-ecological information is detailed in the subsequent sections (Barse 1990; Gnecco and Mora 1997; Ranere and Cooke 1991; Roosevelt et al. 2002; Snarskis 1979).

### **Human Colonization of the Caribbean Lowlands of Central America (11,000 - 5000 YBP)**

Archaeological artifacts supply information about the colonization and adaptation of humans to different types of environments and their putative resources; however, their discovery depends on their selective preservation (Schiffer 1996). In the tropics, the materials most likely to survive are stone tools or products of pyro-technology (e.g., ceramics). Other sources for reconstructing paleo-environments and ancient diets are plant structures such as pollen, starch

grains, and phytoliths, which remain well preserved for thousands of years in the humid, typically unfavorable conditions found in the Caribbean (Piperno 2006b).

Stone spear points, skin scrapers, drills and other tools are among the few pieces of evidence that exist to show the presence of paleo-Amerindians in the tropics. Techno-complexes found in direct association with mega fauna are similar to those found in North America (Clovis) and South America (El Jobo, Fishtail) and have served as proxies to infer hunting strategies and other human behaviors at the end of the Pleistocene (Cooke 1997; Cooke 1998; Cooke and Fonseca 1994) due to the lack such associations in Central America (Roosevelt et al. 2002).

In Panama, Paleo-Indian fluted points —Clovis-like and Fishtail— were found at Lake Madden at the east side of the Panama Canal and at La Mula site at the Santa Maria Basin. These artifacts were indirectly dated between 11,500 and 10,500 YBP (Cooke 1997). At Cueva de los Vampiros, located at the mouth of the Santa Maria River, a fragment of Fishtail was retrieved and dated by association with a separate occupational stratum in cal.  $11,550 \pm 250$  YBP (Cooke and Pearson 2002; Cooke and Sánchez 2004). Jobo-like fragments were also found near the continental divide at the La Yeguada archeological site (Pearson 2002). Other evidence, such as tool pre-forms and early stage reduction of Clovis-like spear points, were associated with a paleo-Indian quarry/workshop in the Nieto site in the Azuero Peninsula (Pearson 2003). Among all these sites, Lake Madden is the only one located in the Caribbean lowlands (Fig.2).

In the Pacific side of Costa Rica, spear points typologically similar to Clovis points were reported for the first time in collections with no clear contextual associations by Carl Hartman of the Carnegie Museum of Pittsburgh (Swauger and Mayer-Oakes 1952). Clovis-like points were found in context in the Arenal Volcano region by Sheets (1994). Both Fish-tail and Clovis-like

spear points were also found in the Caribbean lowlands of Costa Rica (Leon 2007; Snarskis 1979; Valerio 2000).

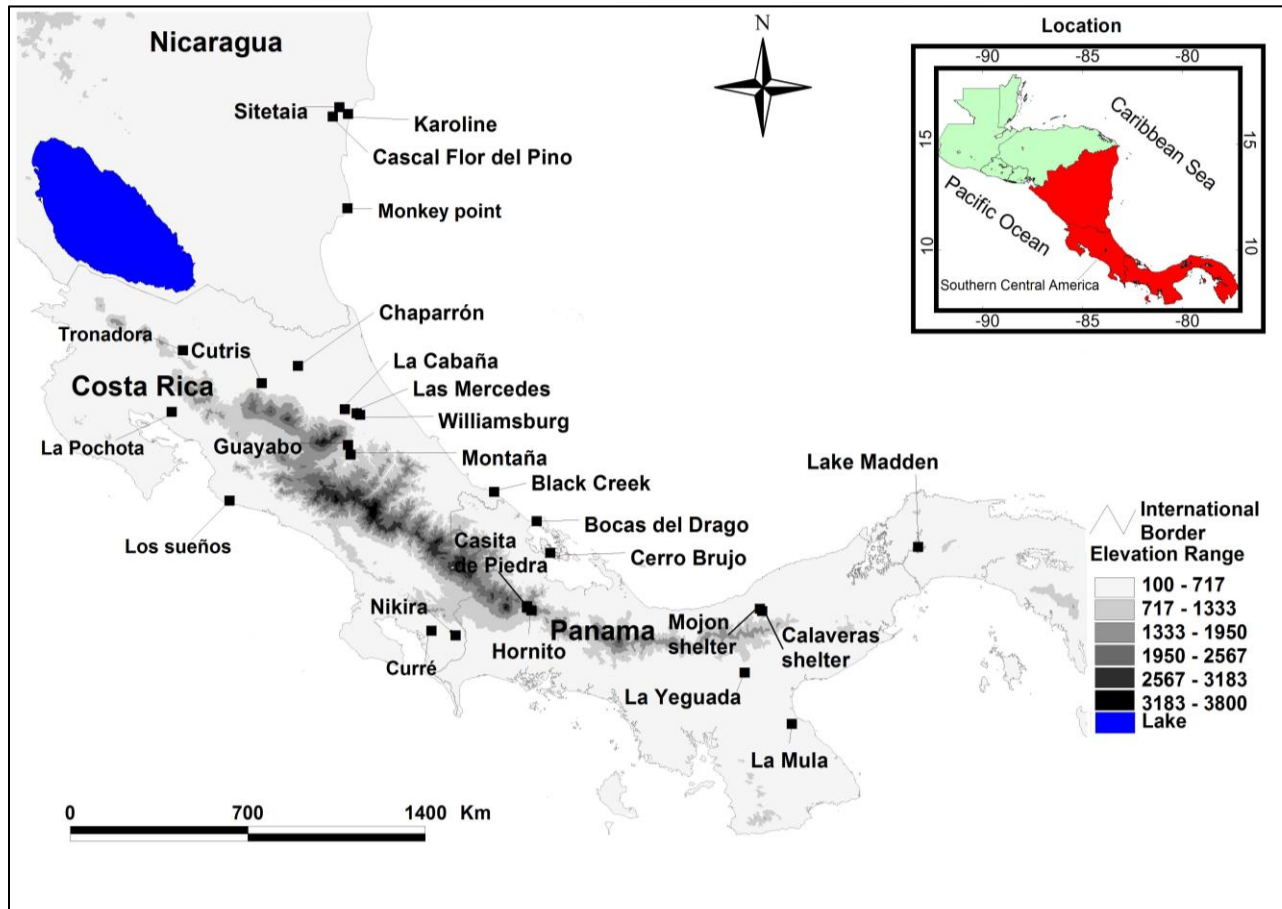

Figure 2. Geographic location of selected archaeological sites named in the text (11,500 - 700 YBP).

The Gigante rock shelter, an important paleo-Indian site located in the southwest highlands of Honduras in the far north of Central America, contains evidence of exploitation of a variety of ecosystems. The lowest levels of this site were carbon dated to the Early Archaic (cal. 9220 and 8750 BCE [2- $\delta$ ]). Recent analysis of this site shows the association with deposits

of lithic, macrobotanical, and faunal remains, and a variety of food items suggesting a mixed and flexible subsistence economy (Scheffler et al. 2012).

Early indications of paleo-Amerindians have been found in Belize. A climate warming linked with the Archaic period (~ 10,000 YBP) indicates a shift in subsistence and the transition from the hunting of Pleistocene species such as bears (Ursidae), peccary (Tayassuidae), and horses (Equidae), to the exploitation of riverine, lacustrine, and marine species (Lohse et al. 2006). The Lowe-ha and Sand Hill phases (11,000 - 7500 YBP) are associated with human adaptations to inland and littoral environments. In these phases, Fishtail spears and long blades were indirectly associated with big game hunting, and adzes were perhaps used for canoe construction. Stone bowls, choppers, grinding stones and other artifacts are also linked with seed collecting and processing of food in the Belize phase (7500 - 6500 YBP). Nevertheless, this evidence is poorly associated in surface contexts and limits archaeological interpretations. The use of aquatic resources in sites located on the Caribbean coast of Belize increased during the Melinda Phase (6500 - 5300 YBP) where net sinkers, scale scrapers, and Shumla-like points were interpreted as resulting from maritime and mixed economies (Hammond 1982).

As it is revealed by these studies, in the late Pleistocene and early Holocene pre-Columbian populations occupied different ecological zones and exploited of a variety of natural resources. The Caribbean lowlands were one of the regions that provided the oldest confirmation of human habitation; however, the association with ecofacts and activity areas is for the most part unknown. More data are necessary in order to make valid interpretations about the human past in the Caribbean lowlands of Southern Central America.

## **Archaeology of the Southern Caribbean Lowlands (4000-100 YBP)**

A number of scholars agree that the limited archaeological research on the Caribbean coast of Nicaragua, Costa Rica and Panama resulted from the difficulty in accessing a region dominated by wetlands and rain forests (Cooke 2005; Cooke and Sanchez 2001; Fonseca 1987; Lange 1984); therefore, the pre-Columbian history of the area is for the most part unknown in comparison to the drier lowlands of the Pacific.

Similar migratory hypothesis used for explaining the peopling of SCA were applied to the Caribbean region of Central America (e.g., Conzemius 1938; Fernandez-Guardia 1975; Pittier 1938; Stone 1966; West 1964); however, the increasing archeological investigations reveals a more complex process of colonization and adaptation to the coasts and lowlands of this region.

In Nicaragua, Costa Rica, and Panama, interest in Caribbean archaeology has been increasing since the nineteen-seventies. The most up to date research has primarily focused on chronological sequences, patterns in subsistence, and short—inland—and long distance—inter-Isthmus— contacts (Baldi 2001; Bray 1984; Chavez et al. 1996; Drolet 1980; Gassiot and Estévez 2004; Hoopes 2005; Linares and Ranere 1980; Magnus 1974; Wake et al. 2004).

Before the nineteen-nineties, only a few archaeological sites on the Caribbean coast of Costa Rica had been reported as a result of systematic excavations, surveys, and archaeological rescue projects (Chavez et al. 1996; Sol 2002; Vasquez et al. 1993). Among those, Black Creek yielded the earliest dates in the coast between cal. 3830 and 2355 YBP [2- $\delta$ ] (Baldi 2011). The presence of this coastal site suggests that the southern coast of the Caribbean Costa Rica had been settled long before the proposed migrations from the Chiriquí River after 1400 YBP, and was culturally connected to the Diquis sub-region in Southeast Costa Rica. This study is



consistent with the population dynamics in this region (Barrantes 1993) and with the hypothesis proposed by Constenla (1995) of an early fragmentation of Chibchan speakers between Costa Rica and Panama between 5000 and 4000 YBP.

The human colonization of the central Caribbean coast of Panama was first proposed by Sigve Linné, Matthew Stirling and associates. Based on ceramic and lithic fragments, they deduced that coastal populations were more primitive and marginal compared to those of the Pacific (Linné 1929; Stirling and Stirling 1964), and that they originated by successive migrations from either south or north America (Stirling 1953). Decades later, Robert Drolet suggested that the Caribbean coast of Panama was occupied by "Colombian" populations after 600 CE (current era) (Drolet 1980). The perspective of long-distance migrations is exchanged for an emphasis on the migration of geographically close populations. For example, John Griggs proposed that the Caribbean watershed in Central Panama was colonized by migrants from the Pacific around 5000 YBP. This inference is supported by the presence of Monagrillo ceramics at Calaveras shelter [LP-8] (Griggs 2005). The Monagrillo ceramics tradition is one of the oldest ceramics traditions in the region and was first reported on the Pacific side of Panama (~ 4500 - 3200 YBP) (Cooke 1995; Cooke 2005). According to Griggs (2005), evidence exists for earlier trans-isthmian contacts than was proposed by Cooke and Ranere (Cooke and Ranere 1992b). Griggs' hypothesis is also supported by similar lithic technology found in western and central Panama and by carbon dates at sites Pn-53 and Lp-8 (cal. 4785 BCE [before current era]). According to Griggs, the migration to the Caribbean was caused by population pressure, agriculture intensification, and decline of wildlife and other resources in the Pacific side (Griggs 2005).

Similar to Griggs' hypothesis, Linares and Ranere (1980) proposed that Bocas del Toro in Panama was populated by migrants from the Pacific side of Panama when corn agriculture made it possible to sustain large population numbers between 3000 and 2000 YBP. Maize agriculture tradition then spread to the highlands of the Chiriquí River where root-crop horticulture, hunting, and the exploitation of local resources such as palms and fruits had been previously established. The root-crops tradition started before 7000 YBP (cal. 7400-5600 YBP) in the Talamanca phase (Dickau et al. 2007). According to this hypothesis, the migration to the Caribbean occurred when corn farming spread in the highlands of the Chiriquí River between 2500-1400 YBP and was stimulated by population pressure and environmental changes caused by the explosion of the Baru volcano (Behling 2000).

This passive scenario of cultural influences has changed based on recent research that pointed out the existence of a complex network of trans-isthmus contacts across the Chiriquí region as early as the second millennium BCE (Baldi 2001; Chavez et al. 1996; Fonseca 1997a), and between Central Panama (Coclé) and northwestern Costa Rica between 1000 and 500 YBP (Chavez et al. 1996; Wake et al. 2012; Wake 2006; Wake et al. 2004).

The Caribbean coast of Nicaragua is the least archaeologically-studied region in Southern Central America (Barahona 1993; Lange 1984) however early archeological reports were provided by Frederick Boyle and Thomas Belt at the Chontales area and Cape Gracias a Dios in the 19<sup>th</sup> century (Stone 1984).

Along the coast of Nicaragua, shell middens, large deposits of shellfish mixed with other animal waste and artifacts, are the most characteristic archeological features. The middens, also served as structural foundations for housing. In 1969 Jorge Espinoza used carbon-14 [<sup>14</sup>C] in 1969 to estimate the antiquity of a shell midden in Monkey Point as between 7600 and 5500

YBP. According to Espinoza, this midden contained evidence of ancient hearths and fishing (Riverstone 2004). If confirmed in the future, these dates would be the oldest in the southern Caribbean coast of Central America. Metates and other sporadic findings have been reported as a result of pre-Hispanic cemetery looting (Riverstone 2004) and re-use by indigenous contemporaries.

Between 1971 and 1976, Richard Magnus analyzed pre-Hispanic evidence in the region, including the southern Caribbean of Nicaragua in Miskito villages, located in the southern part of Pearl Lagoon, Kukra Hill, Bluefields Lagoon and the river basin of Punta Gorda, and established four ceramic complexes based on ceramic types and radiometric dating. The oldest of these traditions was the South American associated tradition Siteioide (2400 – 2000 YBP) followed by the Smalloide (2000 – 800 YBP). These sites contained a large number of artefacts associated with marine and terrestrial game and pre-Columbian fisheries. The model proposed by Magnus established first, the existence of itinerant fishing stations along the rivers and second, in-land sedentary villages. However, these two types of settlement patterns might have changed after European contact when local indigenous populations such as the Miskito relocated to the coast in order to trade with pirates (Magnus 1974; Magnus 1978). In addition, Magnus proposed commercial networks along the northern coast of Central America and the Pacific of Nicaragua from 2500 to 800 YBP based on ceramic styles (Magnus 1974).

Since 1998, a number of archaeological sites in Nicaragua, lithic workshops, middens, and other cultural features have been further studied in the Bay of Bluefields, Pearl Lagoon and Kukra Hill (Clemente et al. 2007; Gassiot and Estévez 2004). In general, research shows intensive exploitation of coastal resources and agriculture since the Formative period (cal. 3070 - 121 YBP). These studies proposed that the richness of the coastal lowlands favored the

development of complex centralized villages similar to Mesoamerican ones such as the Coconut complex in Belize, or the Olmec tradition at La Venta, Honduras. This pre-Columbian pattern of centralized villages is interpreted as distinct from the dispersed villages of extant (and in some cases extinct) indigenous populations on the coast of Nicaragua (Gassiot and Estévez 2004).

### ***DEMOGRAPHY AND RACIAL CLASSIFICATION IN THE 16TH CENTURY***

Early colonial demographic estimates for SCA Amerindians were used to identify race, as a mechanism of social control. The classification of racial types began in SCA in the 16th century, and was based on visible morphological characteristics in the skin, the hair or the shape of the eyes. Populations were geographically located and the number of the inhabitants recorded, as well as reasons for growth or decline —e.g., mortality, migrations, baptisms, marriages—. This information has helped contemporary demographers to estimate demographic changes that have occurred since colonial times.

After the 16th century, Europeans began documenting the great diversity of indigenous groups in SCA (Frazer 1939). Descriptions of “racial types,” despite the strong pejorative charge they conveyed, contained a general view about the demography, the ethnic mosaic, languages, customs and cultural practices in the region. The mix of different ethnic groups in the region included Spaniards, Africans and indigenous people. This mix, in turn, was further diversified with the arrival of more ethnic groups to the region. Indigenous people were identified by their physical and cultural characteristics; Spaniards were both those of Iberian origin as well as the “criollos” or Spaniards born in America; “Ladinos” were the result of different ethnic groups mixing, although they were culturally Spanish; and finally the resulting admix with people of African origin (Hall and Perez-Brignoli 2003). Racial descriptions were founded on the

Spaniards' worldview and on the external appearance of the indigenous people (e.g., Fernandez de Oviedo 1959 [1535-1557 and 1851-1855]). The delineation of the pre-Columbian human geography was continued in the 19<sup>th</sup> and early 20<sup>th</sup> centuries by scholars such as Henri Pittier, Anastasio Alfaro, and Jorge Lines who established the first divisions of "races", for example in Costa Rica (e.g., Fernández-Guardia 1921; Fernández 1975; Lines 1952; Peralta 1883; Peralta 1886; Peralta 1898; Pittier 1938); however, these classifications lacked scientific rigor and diachronic perspective of social and biological evolution.

Among the most important chroniclers of the Spanish Conquest are Gonzalo Fernández de Oviedo y Valdez and Fray Bartolomé de las Casas, who compiled important descriptions of the region's population (Carmack 1994). In addition, the chroniclers of the 18<sup>th</sup> and 19<sup>th</sup> centuries include information about settlement patterns, as well as of the cultural and economical practices of the indigenous populations (Fernández-Guardia 1921; Fernández 1975; Gonzalez and Zeledon 1999; Ibarra 1986; Peralta 1883; Roberts 1978 [1827]; Solorzano 2000). Some sources, such as Bartolomé de las Casas and Juan López de Velazco, are of particular relevance since they were among the first to estimate the size of native populations, their spatial distribution and their associated customs. The shortcoming of these works, however, is that they only represent a gross approximation of the native populations (Denevan 1976b). Population estimates have also been re-examined by contemporary researchers (Table 2), but these studies are highly descriptive and population numbers vary depending on the author's own research. Recently, the combination of different historical sources with ecological variables such as carrying capacities are improving the demographic estimates in SCA (Tous Mata 2002).

Table 2. Population estimates at the beginning of the sixteenth century in Central America.

Author	Reference	Estimate population (16th century)
Steward and Faron	(Steward and Faron 1959)	736,500
Angel Rosemblat	(Rosemblat 1954)	800,000
William Sherman	(Sherman 1979)	2,250.000
Alfred Kroeber	(Kroeber 1992 [1939])	3,000.000
William Denevan	(Denevan 1976c)	5,650.000
Karl Sapper	(Sapper 1924)	5,000.000 - 6,000.000

Between 1500 and 1680, the Central American indigenous populations declined drastically, with mortality remaining on the rise for the next 200 years due to exposure to new pathogens for which the native population had little to no immunity. Recently introduced diseases such as smallpox, typhus, measles, chicken pox, malaria, and cholera, contributed to the extinction of thousands of indigenous peoples in a few years (Crawford 2001; Denevan 1976a; Hall and Perez-Brignoli 2003; Solorzano and Fonseca 2006). Also, the decline in population was aided by slavery, malnutrition, military action, and mistreatment. For instance, under the rule of governor Pedrarias Dávila in 1516, slavery became the most important economic activity in Nicaragua, and remained so until 1540 (Denevan 1976b). Slavery displaced over 500,000 indigenous people from their places of birth to Peru and Panama at the beginning of the 16th century (between 1527 and 1536), and resulted in the death of between 400,000 and 600,000 individuals due to different maladies. The western region of Nicaragua also suffered a steep decrease in population, going from 100,000 inhabitants in 1503 to 10,000 within a period of less than ten years. The documented number of indigenous slaves has served as an indicator of the size of the population in Nicaragua during the early stages of the Conquest (Radell 1976). An increase in the indigenous population in this country and the rest of Central America occurred from the 18th century onward, made possible by mixing with other ethnic groups of mostly European and African descent (Denevan 1976a; Hall and Perez-Brignoli 2003).

Demographic estimates in Panama during the 16th century vary considerably. Castellero (1995) estimated a population of between 150,000 and 225,000 inhabitants; and Steward and Faron (1959) between 225,000 and 250,000 inhabitants. On the other hand, Sauer (1966) proposed that the population may have been as large as 600,000. The same problems arise in Costa Rica, where some references point to a small indigenous population of 8281 inhabitants scattered throughout the territory (Hall 1984) while other authors, such as Ferrero (2001) and Fernández de Oviedo (1959 [1535-1557 and 1851-1855]), estimated 350,000 and 400,000 inhabitants respectively. Over all, these figures are unreliable since colonial archives did not include regions such as the Costa Rican and Nicaraguan Caribbean until much later (e.g., Peralta 1883; Peralta 1898). Recent studies, however, have estimated 40,000 individuals living in the Nicaraguan Mosquitia at the eve of the European contact based on the carrying capacity of the environment (Newson 1987).

### ***ETHNO-LINGUISTIC DIFERENTATION IN SOUTHERN CENTRAL AMERICA***

Since Steward and Faron (1959) hypothesized that Amerindian languages are correlated with cultural areas, this relationship has been increasingly used in anthropological genetics to test hypotheses of genetic structure and the correlation of gene and language evolution (Croft 2008).

The classification of the American Indian languages widely used by anthropologists is based on Greenberg's hypothesis of the peopling of the Americas. The three wave model distinguishes three stocks: Amerind, Na-Dene, and Aleut-Eskimo. The first of these covers almost all of the New World. The second, Na-Dene, is found in southern Alaska and northwestern Canada. The third, Aleut-Eskimo, is found in the northern extreme of North America. The three groups are hypothesized as representing the settlement of the New World by

successive migrations from Asia (Greenberg et al. 1986). This model was not without criticism due to the lumping of several linguistic groups into only three major categories (Nettle 1999); however, recent genetic evidence has supported Greenberg's hypothesis (Reich et al. 2012).

The Amerind linguistic group was subdivided into linguistic families including the Chibchan family, the most extended in SCA (Fig.3) (Holt 1997-1998). Several hypotheses have been put forward to account for the origins and relationships of the Chibchan languages. In 1955, Swadesh proposed that Mesoamerican populations dispersed into Central America about 7000 years ago following the fragmentation of Uto-Aztecs and Macro Mayan speakers. This was followed by the fission and migration of Chibchan speakers to SCA (Swadesh 1955a; Swadesh 1955b). Other linguistic groupings have been established, such as the phylum Macro-Chibchan which includes a number of related languages from South America to SCA, but the proposed extent of this phylum varies among authors (Greenberg 1987; Kaufman 1990).

Constenla (2005) on the other hand, proposed a linguistic coalescence of the Proto Lenmichí linguistic group around 10,000 YBP that was subsequently subdivided around 8000 and 7000 YBP into the antestral linguistic lineages of the today's Lencan, Misumalpan, Payan, and Chibchan speakers (Fig.4). Constenla (1991; 2002a; 2008) hypothesized that Chibchan populations originated on the lower isthmus of Central America and that an early fragmentation of the proto-Chibchan languages occurred around 5000 YBP with the introduction of agriculture, when farmers migrated from two hypothetical centers between southern Costa Rica and Panama:

“The distribution of the languages suggests that the ancestor of Family A (Teribe [Tiribí], Bribri, Cabecar; Boruca, Movero, Bocota) occupied the Atlantic coast of Southeast Costa Rica and Western Panama, while the ancestor of B (Paya, Rama, Guatuso; Dorasque, Changuena) was distributed along the Pacific coast, with the geographical barrier established by the



mountain range of Talamanca possibly being the factor causing this division” (Constenla 1991: 42-43, our translation).

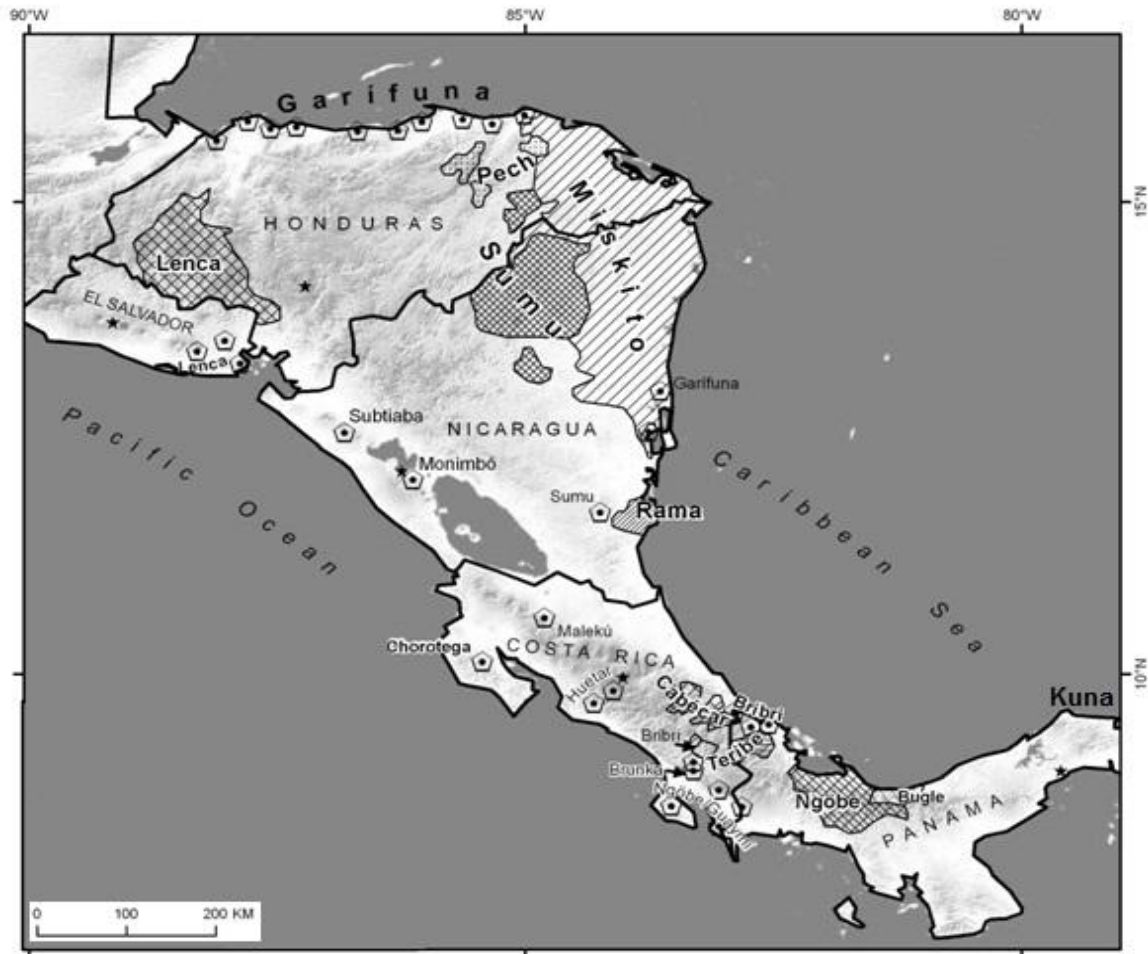

Figure 3. Existing ethno-linguistic populations from Southern Central America. Chibchan speakers: Kuna, Buglé, Ngöbé, Teribe, Brunka (Boruca), Bribri, Cabecar, Huetar, Maleku, and Rama. Modified from Herlíhy (1997).

This expansion was followed by the movement of indigenous populations out to the neighboring regions in Eastern Honduras and Northern South America.

The adoption of land-based agriculture and the long-term permanence of the populations within a geographic area stimulated fragmentation and regionalization of populations and

languages and contributed to the movement of populations and the development of communication networks within the Intermediate Area (Constenla 1991).

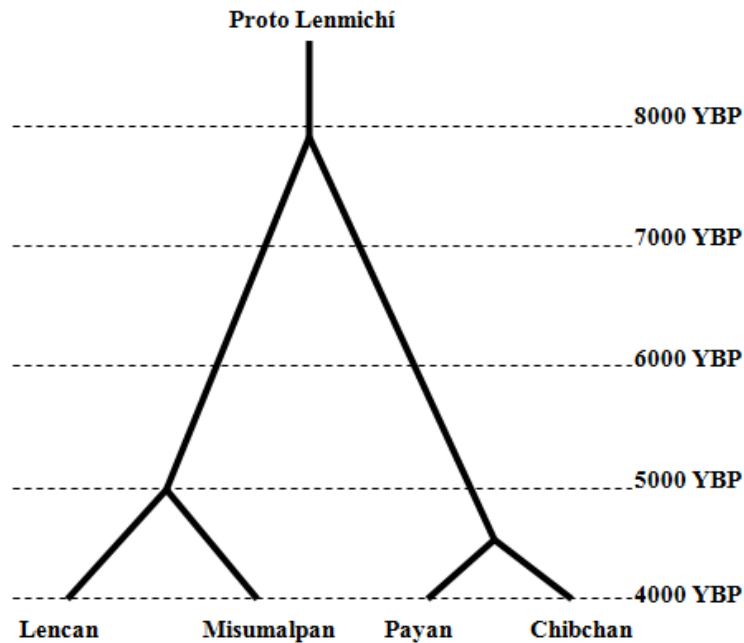

Figure 4. Linguistic coalescence of Macro-Chibchan languages according with Constenla (2005).

### ***NATIVE AMERICAN BIOLOGICAL VARIATION OF SCA***

In order to approximate the genetic variation and population dynamics of indigenous groups in SCA, studies of biological anthropology have gone through different periods, each reflecting the intellectual environment of the time. In this section, studies on human diversity and genetic structure are organized in three historical phases: a) studies that focused on morphology and human classification, b) studies on microevolution and phylogenetic relationships based on classical genetic traits, c) studies on molecular genetics that emphasize patterns and consequences of human variation and evolution.

## **Morphological-Classificatory Studies**

Before the discovery of the blood-groups systems, protein, enzyme polymorphisms or DNA analysis, anthropologists described human variation by using quantitative traits such as anthropometrics and dermatoglyphics (Rolethford 2007). In SCA, anthropometric studies among the Sumo and Rama Amerindians were conducted in 1924 by Schultz (1926) when he took part in an expedition organized by the John Hopkins Medical School in eastern Nicaragua. Similar studies were done by Hrdlicka (Hrdlicka 1926) with the Kuna of Panama, and by Laurencich de Minelli among the Boruca, the Guaymí, the Bribrí and the Cabecar groups in Costa Rica (Laurencich 1966; Laurencich 1968; Laurencich 1974). Also, Mexican-Italian Ada D'Aloja developed demographic and anthropometric research between 1937 and 1939 among indigenous groups from Nicaragua, El Salvador, Honduras and Guatemala (D'Aloja 1939; D'Aloja 1940). These investigations relied mostly on the typological paradigm first proposed by Carolus Linnaeus (1707-1778) and adapted for human studies by J.F. Blumenbach, and other founders of biological anthropology in the 18<sup>th</sup> century. This perspective was based on the segregation of human groups according to their external —morphological— characteristics and their geographic location (Fig.5).

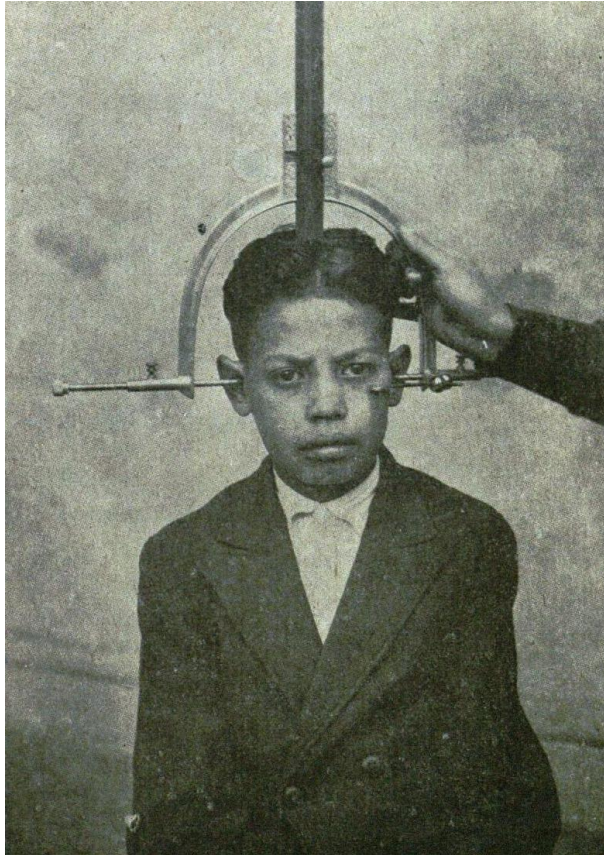

Figure 5. Antropometric studies among Indigenous populations from the east coast of Nicaragua. Photograph taken by Ada D'Aloja (1939).

Although quantitative anthropometric methods and knowledge of human anatomy improved during the 19th century, the typological paradigm continued during the 20th century, focusing on Mendelian genetics by means of the ABO blood-system frequencies (Mielke et al. 2006). The work of Gian Franco de Stefano and Jorge Jenkins in Nicaragua was the first attempt to understand the biological and cultural causes of variability in local indigenous populations in SCA. The researchers based their interpretations on anthropometric and genetic data —blood groups— obtained among Rama, Miskito, Sumo, Subtiba and Ladino populations between 1969 and 1971 (De Stefano 1970-1971; De Stefano 1973; De Stefano et al. 1979; De Stefano and

Jenkins 1970-1971; De Stefano and Jenkins 1972; De Stefano and Jenkins 1972-1973; De Stefano and Jenkins 1974; De Stefano and Jenkins 1976). Apart from the biological information, De Stefano and Jenkins included linguistic affiliation, population history, geographical location and demographic relationships among native populations from Nicaragua. These studies show that the Sumo, Rama, and Miskito from the Mosquitia region are more closely related to one another than they are to the Subtiaba and the Ladinos from the western region. The authors concluded that such biological affinities reflect not just geographic relationships but similar social structures, culture, and language.

A second series of morphological studies that emphasized population structure was developed within the context of the research conducted by Barrantes and his colleagues among the Bribri, Cabecar, and Guaymí Amerindians from Costa Rica and Panama after the 1970's (Barrantes 1993). This research used dermatoglyphics and demonstrated its applicability for inferring population structure at the tribal level (Quesada and Barrantes 1983; Quesada and Barrantes 1986; Quesada and Barrantes 1991; Wang and Barrantes 2008), as did dental morphology of Chibchans from Costa Rica (Brenes and Barrantes 1983; Brenes and Barrantes 1986).

### **Classical Polymorphisms and Microevolutionary Studies**

Since Lardsteiner developed the ABO blood-system in 1900, there has been an increased interest in collecting and studying the distribution of the different blood groups around the world, particularly in the Americas (Crawford 2001; Mielke et al. 2006; Neel 1978; Neel and Salzano 1964).

The assessment of Amerindian genetic variation was possible through the development of electrophoretic methods using primarily blood cell proteins and enzymes referred to as “classic genetic markers” (ABO, Rhesus, MNS, Duffy, and others) (Crawford 2007). Based on serologic analysis and blood group frequencies, William Boyd (1952) proposed the distinctiveness of the American Amerindians, and then blood cells were collected among indigenous populations in the Americas. In SCA, the compilation of genetic variations in classical blood markers was done by Albin. G. Matson and other researchers during the 1970s. This was followed by studies of genetic population structure by Barrantes and colleagues. The studies on indigenous SCA biological anthropology were a continuation of the research that James V. Neel had begun in the middle of the 20<sup>th</sup> century among the Xavante in Brazil and the Yanomamo in Venezuela (Neel 1978; Neel and Salzano 1964; Neel and Salzano 1967). Neel wanted to understand how the conditions regulating survival and reproduction had changed from “pre-civilized” indigenous groups to modern populations, and what evolutionary forces operate in shaping the genetic structure of populations (Neel 1994). Field work and the collection of demographic and ethnographic data was important for testing such models *in vivo* (Ventura 2003).

Classical polymorphism was the first genetic system used for evaluating the origins of the Amerindian populations, the number of migrations and the chronology of events (Crawford 2001); however, these types of studies began to emerge in Central and South America in the nineteen sixties with Fuentes (1961) among the Guatuso Amerindians in northern Costa Rica, and Matson and Swanson (Matson and Swanson 1963b; Matson and Swanson 1965a; Matson and Swanson 1965b) who systematized the genetic frequencies of several indigenous populations by using different polymorphic systems (ABO, MNS, P, Diego, Duffy, Kell, haptoglobulins, transferins and hemoglobins). The Manson and Swanson studies were mostly

descriptive and aided by chi-square ( $X^2$ ) and tables of gene frequencies. Admixture estimates were discussed on the assumption that the frequency of A and B blood groups and other haplotypes were non American in origin. Manson's methodology was criticized for its sampling method (Barrantes 1993). Despite this criticism, Mason's data is still a useful reference for establishing phylogenetic relationships of indigenous populations from Central and South America (Melton 2008; Post et al. 1968).

When Fitch and Neel (1969) analyzed blood samples of several of these SCA populations, they proposed the close genetic relationship between the Guaymí from western Panama and the Yanomamo from southern Venezuela. This hypothesis was later tested by Spielman, et al. (1979) who did not find evidence of any such relationship, but instead discovered two new private polymorphisms (DH\*BGUA and ACP\*BGUA) among the Guaymí and the absence of Albumins in the Yanomamo (Tanis et al. 1977). Based on new data collection that included blood samples, anthropometrics, and linguistics within different Guaymí villages, Spielman and colleagues found substantial differences between the Yanomamo and the Guaymí, arguing that these two groups were not "recently biologically related" as was previously assumed. Instead, they claimed, they had diverged around 4000 years ago. Crawford (1979) acknowledged the importance of this research as among the first in Latin America that combined genetics, linguistics, and anthropological methods in the studying of human variation and evolution.

These works heeded new comparative studies on indigenous groups of similar linguistic phyla. The work of Barrantes et al. (1982) is the first attempt to establish the intra-population variation between two Guaymí communities from Costa Rica (Limoncito and Abrojo) and their relationship with other Chibchan speaking populations from Southern Central America and

Northern South America. Barrantes and colleagues analyzed three systems: blood group, plasma proteins, and erythrocyte proteins from previously published sources and original data obtained from the field (Barrantes 1993). A total of 42 loci were analyzed, and genetic distances were performed on 10 alleles using a minimal string network. The authors found a coherent relationship for three geographically separated groups: Central [B], Northern South American [A], and Chocoan speaking population [C]. Most of the indigenous Chibchan speaking populations cluster together (Fig.6), however, using a bigger sample size of 22 Chibchan populations from Colombia and Central America and 25 polymorphisms, Layrisse, et al. (1995) did not find clear philogenetic relations among these populations.

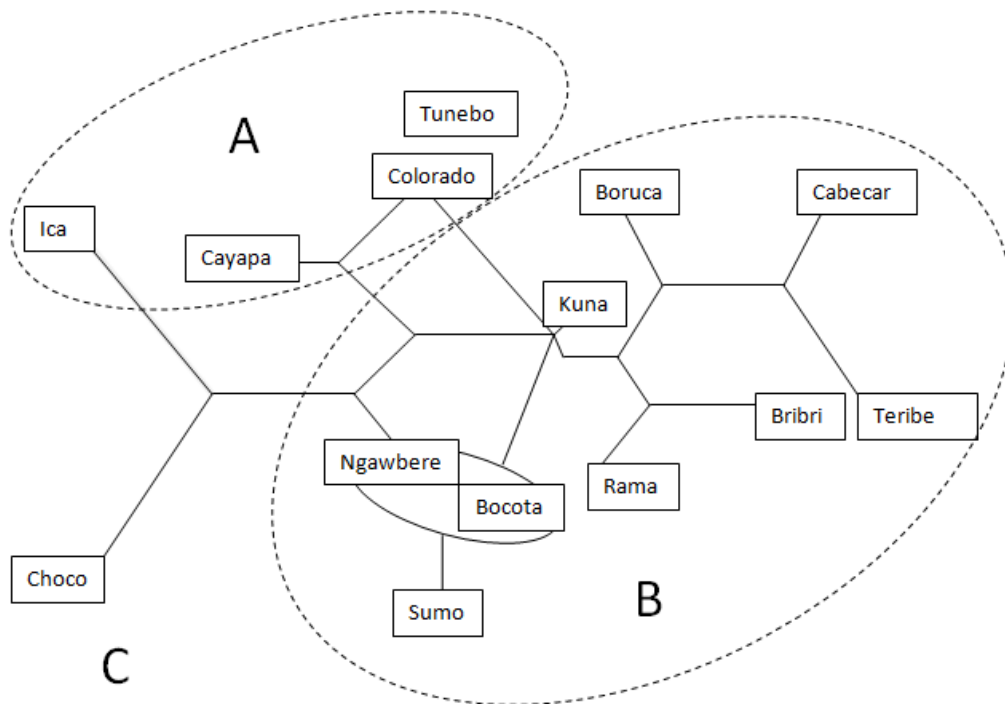

Figure 6. Minimum string network showing genetic relationships among: South American Chibchan Populations A, Central American Chibchan populations [except of Sumo] B, Chocoan speaking population, C. Modified from Barrantes, et al. (1982).



Barrantes, et al.(1982) proposed that the fission-fusion process, or radiations and aggregations, of populations among Ngawbé was responsible for their population structure. Subsequent publications (Azofeifa et al. 1998; Azofeifa et al. 2001; Barrantes 1993; Barrantes 1998; Barrantes et al. 1990; Bieber et al. 1996) revealed that a hierarchical organization, an east-west pattern, of Chibchan speaking populations was likely influenced by social structure, environmental conditions, and geographic isolation. The combination of these factors generated higher frequencies of transferines D-Chi, the 6PGD allele, and the absence of the Diego A\* allele (DiA\*), as well as regionally restricted polymorphic variants (Table 3). The genetic differentiation of Chibchan populations in SCA (Fig.7) underpins the hypothesis of an *in situ* development of Chibchan populations and their divergence around 7000 YBP. The local development model also implies the absence of genetic influx by relatively recent pre-Columbian migration from Mesoamerica and South America. The hypothesis of the *in situ* microevolution of Chibchan populations was tested by Thompson, et al. (1992) who proposed that the frequency and antiquity of such mutations were attributed to the ancient divergence of Chibchan speakers and their permanence in the territory for thousands of years.

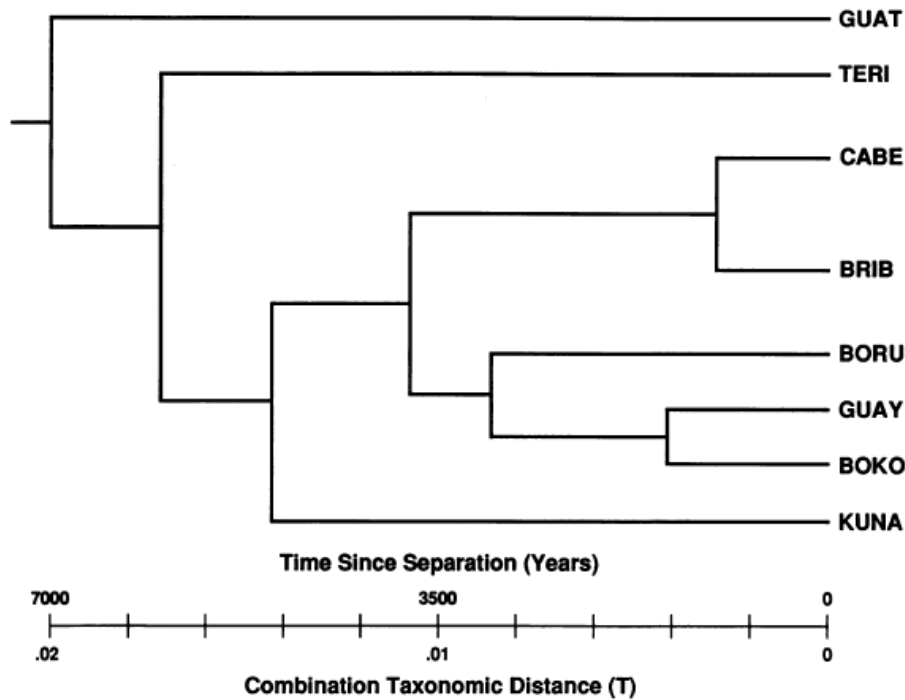

Figure 7. Phylogenetic tree showing the ancient Chibchan divergence around 7000 YBP and cluster relationships among eight SCA indigenous populations. From Thompson et al. (1992).

Table 3. Mutations found in Chibchan speaking populations from Southern Central America. Modified after Barrantes (1998).

Recent mutations	LDH*GUA ESA2*BOK DI*A 6PGD*C
Intermediate mutations	TF*GUA ACP*GUA TP13*BRI GOTS*3 6 BP del. HUET.
Ancient mutations (<7000 YBP)	GOTS*2 PEPA*KUN TF*DCHI

Studies on classical genetic markers provide a gross approximation of the complexity and the genetic history of the indigenous populations in SCA; however, they paved the way for later studies of greater evolutionary resolution such as investigations of molecular markers. In addition, microevolutionary studies based on classical markers provide the foundation for testing the hypothesis of the coevolution of culture and genetics in the Isthmo-Colombian area (Arias et al. 1988b; Barrantes 1993; Constenla 1991; Cooke and Ranere 1992a; Fonseca 1998; Hünemeier et al. 2012).

### **Molecular Polymorphisms and Microevolutionary Studies**

After Watson and Crick broke the genetic code, revolutionary techniques with applications for the study of human variation in SCA became available for research in Anthropological Genetics (Crawford 2007). Unlike the indirect investigation of biochemical markers such as protein and enzyme polymorphisms, four principal discoveries have permitted the direct study of the DNA molecule in the last thirty years. Restriction enzymes make it possible to cleave strands of DNA in specific positions; DNA hybridization techniques facilitate the comparison of different species through the similarity or difference of their nucleotide constitution; Polymerase Chain Reaction (PCR) creates “copies” of DNA sequences in geometric progression; and finally, automated DNA sequencing permits the rapid characterization of the human genome (Rubicz et al. 2007). These inventions established the genetic variability and worldwide phylogenetic relationships among and within human populations by facilitating the study of several DNA polymorphisms (i.e. SNPs, RFLPs, VNTRs, STRs, mtDNA), the non-recombining portion of the Y-chromosome (NRY), and autosomal DNA (Bhasin and Walter 2007). This so-called molecular revolution opened new avenues to anthropological studies on

major demographic expansions, modern human origins, the peopling of the Americas, evolutionary relationships between *Homo sapiens* and other hominids, and microevolutionary processes of small-geographic-scale populations (Crawford 2007a; Jobling et al. 2004).

The human genome is constituted of 22 pairs of autosomal chromosomes and two sex chromosomes (XX and XY), and mitochondrial DNA (mtDNA). The mtDNA is a circular, 16,569 bp long molecule (Fig.8) that does not recombine with other DNA molecules and is transmitted matrilineally. The pattern of inheritance of the mtDNA makes it possible to trace the evolutionary history of female lineages as far back in time as ~150,000 – 250,000 YBP (Ingman et al. 2000).

The major part of this molecule is constituted by the coding region where 13 polypeptides are responsible for the oxidative phosphorylation, the metabolic pathway in the cell that uses energy by the synthesis of adenosine triphosphate (ATP). In the mtDNA molecule two particularly informative regions are the subject of anthropological interest, the hyper variable region I (HVS-I) and the hyper variable region II (HVS-II). Both regions are located side by side in a non-coding-region or D-loop that is ~1200 bp long. Another advantage of the mtDNA molecule is that the non-coding region accumulates mutations at a higher rate, averaging  $2-3 \times 10^{-7}$  per nucleotide per generation and around 0.043 mutations per generation in the coding region, allowing the reconstruction of evolutionary events in a relatively short time scale (Meyer et al. 1999; Tishkoff and Gonder 2007).

In SCA, studies on mtDNA polymorphisms consist of Restriction Fragment Length Polymorphisms (RFLPs) analysis and the sequence of HVS-I and HVS-II of the mtDNA control region and whole genome sequence. RFLPs are also used to characterize small nucleotide polymorphisms (SNPs) and 9-base paired deletions (9-bp) located in the coding region of the

mitochondrial molecule. These polymorphisms define the major haplogroups present in America (A, B, C, D, and X) and other continents inherited by the maternal side (Rubicz et al. 2007). Haplogroups are groups of related haplotypes defined by a set of shared RFLPs mutations that are specific to human populations (Mielke et al. 2006) and are correlated with cultural affiliation, linguistic family and geographic location (O'Rourke et al. 2000).

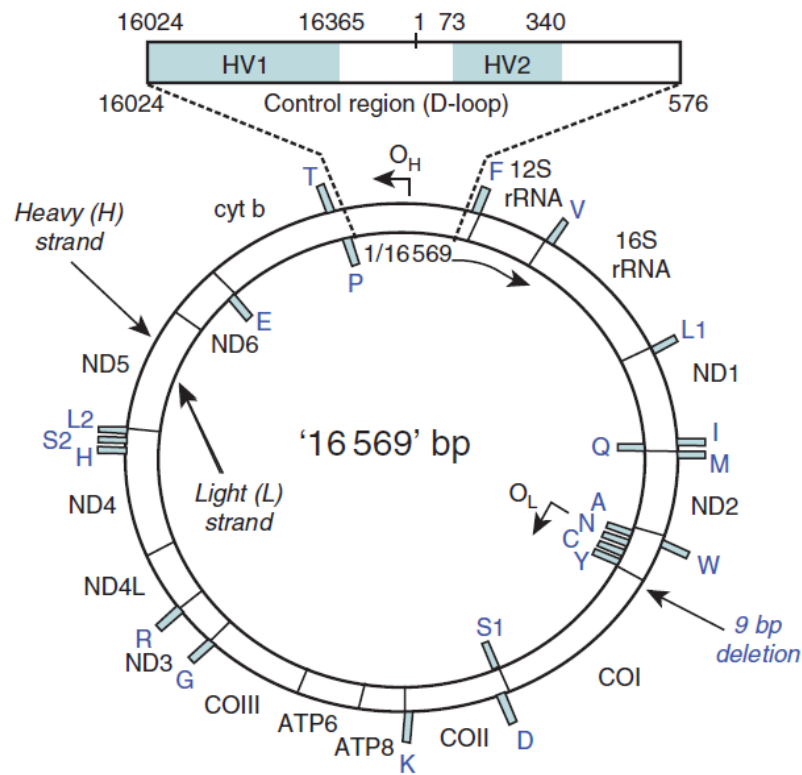

Figure 8. Physical map of the mtDNA molecule after Butler (2005).

At the continental level, studies on mtDNA have increased the amount of resolution by sequencing the complete mitochondrial genome or/and the control region and SNP typing, augmenting the basal haplogroup classification and adding up to ten monophyletic sub-

haplogroups of four major clades (A2, B2, C1b, C1c, C1e, C4c, D1, D2a, D3, and D4h3a) (Achilli et al. 2008; Bandelt et al. 2003; Ebenesersdóttir et al. 2011; Malhi et al. 2010; Perego et al. 2009; Tamm et al. 2007).

Compared to the X chromosome, autosomal, and the mtDNA, the NRY has lower levels of genetic diversity, due to its low effective population size ( $N_e$ ) and its proclivity for genetic drift. Despite low levels of genetic diversity and abundant polymorphisms, this genetic system is suitable for studying variation across ethnically diverse groups. Differences in effective population sizes between the mtDNA and NRY systems provide two genetic histories regarding the time of the most common ancestor (TMCA) (Tishkoff and Gonder 2007).

The forces of evolution, the pattern of inheritance, and the effective population size of both systems (NRY and mtDNA) provide two genetic perspectives on population structure and diversity of human populations. The determinant factor for the spread of genes across population boundaries is accessibility to mates, which in turn is related to the degree of geographic isolation. The less the physical distance between populations, the greater the chance of gene flow. In addition, matrilineal or patrilineal residence impact the patterns of mtDNA and Y-chromosome diversity (Jobling et al. 2004).

### ***Mitochondrial DNA (mtDNA) Markers***

After the sequence and organization of the mtDNA were published (Anderson et al. 1981) and the mitochondrial Eve hypothesis proposed (Cann et al. 1987), an increasing number of mtDNA genetic studies in SCA attempted to achieve four distinct aims: first, to model the first human migrations to the American continent; second, to test hypotheses of the genetic relationships between Chibchan populations from SCA; third, to understand the relationship of

Chibchan populations within a broader Central and Northern South American context and the evolutionary implication of these relationships; and fourth, to look at the indigenous and non-indigenous genetic component within national gene pools.

In order to investigate possible scenarios of the early migration to and colonization of the Americas, Torroni, et al. (1993) proposed the phylogenetic relationship between Native American tribes and Asian populations by studying the D-loop section of the mtDNA. This study found a high incidence of private mtDNA polymorphisms and a limited proportion and distribution of shared mutations among populations caused by their geographical isolation and tribal fragmentation. The calculation of the time divergence of the four major haplogroups present in Native American tribes indicated that the more likely upper limit for the peopling of the Americas was between 40,000 and 20,500 YBP. Within this study, Chibchan speaking populations were used for comparative purposes. Subsequent mtDNA variation analysis tested the hypothesis of the early tribalization and microevolution of indigenous populations from Panama and Costa Rica (Torroni et al. 1994). Based on the molecular clock, this study estimated the separation of Chibchan speakers from other linguistic groups around 10,000 YBP. This was followed by the accumulation of distinctive mutations before the group split into discrete tribes. A subsequent examination of the haplotype diversity of the Ngöbé Amerindians from Panama (Kolman et al. 1995) detected lower diversity values at the HVS-I and II regions in comparison with the Nuu-Chah-Nulth and the Haida from the Pacific Northwest and with the Mapuche from Chile. Only two (A and B) of the four major haplogroups were found among the Ngöbé. According to this study, the expansion of the Ngöbé (~ 6800 YBP) coincides roughly with the ethnogenesis of the Chibchan populations (10,000 – 7000 YBP), followed by their estimated expansion around 4000 YBP with the spread of specialized agriculture (Kolman et al. 1995). The

low levels of mitochondrial diversity values found among the Kuna from western Panama were also concordant with the values obtained among the Ngöbé and the Huetar in previous studies (Batista et al. 1998; Batista et al. 1995). Furthermore, the Kuna carried only two (A and B) of the four major founding lineages in the Americas. The study concludes that modern Chibchan-speaking populations experienced a population bottleneck occurring ~10,000 YBP, and/or by the European colonization (Batista et al. 1998; Batista et al. 1995).

While examining the genetic variability of the Huetar from the Central Valley of Costa Rica, Santos, et al. (1994) discovered a distinctive 6-bp deletion in the control region HVS-II between nucleotide pairs (np) 106 and 111. This mutation was named the “Huetar deletion” and it corresponds with the *MspI* site loss at nucleotide position 104 within the haplogroup A2 that appears in some Chibchan-speaking populations of Central America, including the Teribe, Bribri, Cabécar, Boruca, Guaymí (Ngöbé and Buglé), Kuna (Santos and Barrantes 1994; Santos et al. 1994; Torroni et al. 1994; Torroni et al. 1993), and Chorotega (analysis in progress). The Huetar deletion is also wide spread among contemporary Panamanians and considered a marker of the lineage A2af by Perego et al. (Perego et al. 2012).

Kolman and Bermingham (1997) carried out the first study that combined mtDNA (HVS-I and HVS-II), nuclear, and Y-chromosome genetic markers between two Chocó-speaking populations from eastern Panama, the Emberá and Wounan and the Chibchan Kuna and Ngöbé. The authors concluded that patterns among the Chocoans differ from the reduced diversity found among Chibchan populations. This trend supports the scenario of endogenous cultural development, regionalization and microevolution of SCA populations.

A number of recent studies have attempted to understand the genetic structure and diaspora of Chibchan speakers from Central and South America. Melton, et al. (2007) examined



the hypothesis of biological relationships between Chibchan populations of SCA and northern Colombia in relation to the peopling of South America with three Chibchan populations (Kogi, Arsario, and Ijka), and one Arawak speaking population (Wayuu). In this study, Melton and colleagues detected a shared number of HVS-I Chibchan genetic characteristics: low haplotype diversity ( $H$ ) estimates among groups, positive Fu's  $FS$  indicating population drift and low  $M$ -values that showed reduced heterozygosity. In this case, the absence of shared mtDNA haplotypes is indicative of a linguistic separation from an ancient stock during the Pleistocene/Holocene transition. The human diaspora from Central America to northern South America happened, according to the mitochondrial clock, between 14,000 and 8000 YBP. Due to the climatic and subsistence shift from hunting and gathering to a horticulture (10,000 - 7000 YBP), Chibchan populations remained geographically isolated between SCA and northern South America. The transition to the Holocene facilitated the exploitation and adaptation to a variety of microenvironments, allowing sedentarism and relative genetic homogeneity due to reduced genetic flow from other regions. According to this model, the population growth in the Central American isthmus blocked subsequent migrations from the north, forcing populations from northern South America to move further south. This study also found a genetic relationship in the distant past with Mayan populations from Central America. The genetic affinity between these populations provides a more complex scenario than the *in situ* microevolutionary hypothesis proposed by the Barrantes group.

A second study (Melton et al. 2013; Melton 2008) examined Y-chromosome and mitochondrial DNA genetic variation of 230 individuals from five populations (Rama from Nicaragua, and Huetar, Maleku, and Guaymí from Costa Rica). The main objective of this study was to determine the evolutionary history and genetic relationships among Chibchan-speakers

and neighboring populations. Looking at the mtDNA, this study found biological relationships between the Chorotega and SCA Chibchan groups, but also to the K'iche' Maya from Mesoamerica based on haplogroup D1. The absence of this haplogroup in most of the Chibchan populations and its presence among the Chorotega and Huetar has two possible explanations: its presence may be the result of gene flow between Mesoamerican migrants and Chibchan populations inhabiting the Guanacaste and the central region of Costa Rica approximately 1200 YBP, while its absence among most of the Chibchan populations may be a result of genetic drift that led to the loss of D1.

Chibchan populations are also differentiated from eastern South American and Andean populations. Low mtDNA diversity values and positive neutrality tests indicate genetic drift that contrasts with high values at the Y-chromosome level mainly due to genetic the influx of Mesoamerican and Europeans males. In addition, coalescent dates based on haplogroup A2 indicate the divergence of Chibchan groups from Paleoindian populations between 10,000 and 8000 YBP and the early separation and isolation of Lower-Central from North and South American populations. This fragmentation is coupled with a genetic discontinuity that was detected south of the Lake Nicaragua (Cocibolca) (Melton 2008). According to Bergoening and Protti (2006), this region of extensive wetlands was formed during the mid- and late-Pleistocene.

### ***Y-Chromosome (NRY)***

To date only three studies in SCA have attempted to place indigenous populations within a phylogenetic context using NRY markers (Ascunce et al. 2008; Melton 2008; Ruiz-Narvaez et al. 2005), and two studies combined different polymorphisms for the genetic characterization of

Mestizos in Nicaragua and indigenous populations in Panama (Kolman and Bermingham 1997; Nuñez et al. 2010).

Y-chromosome, mtDNA, and the X-chromosome markers of the Emberá and the Wounan were compared with the Ngöbé and Kuna from Panama by Kolman and Bermingham (1997). This study did not find signs of population structure at the nuclear DNA and the Y-chromosome level. It was proposed that the large genetic variance of the Y-loci was caused by the effect of polygamy since it is a common marriage practice among Panamanian indigenous groups.

A subsequent NRY study by Ruiz-Narvaez et al. (2005) established the phylogenetic relationship between five Chibchan speaking populations from Costa Rica and Panama and other non-Chibchan South American populations. The dendrogram of this study shows a cluster relationship between the Cabecar, Huetar, Teribe, and Bribrí from SCA linked to the Gãviao from Brazil and Cayapa from Ecuador; all of them are separated from the Guaymí. The close relationship between the Chibchan groups and the non-Chibchan Gãviao is enigmatic; nevertheless, the relationship between the Central American Chibchan populations and the Cayapa is plausible since they belong to the same linguistic stock. The more genetically diverse group was the Huetar (0.942) possible due to their high level of interethnic admixture. In contrast, the least diverse group was the Guaymí (0.679), a more isolated population. The genetic variation of the Y-chromosome was greater within tribes than between tribes. Comparatively, with the mtDNA restriction data, there was no evidence of differential structuring between maternally and paternally inherited lineages. Based on mismatch distributions of the Q-M3 haplogroup, the coalescence time between 3,113 and 13,243 is for the most part concordant with the origin of Chibchan groups and with historical linguistics and archeology.

A third study examines the haplotype variation of 13 STRs among four indigenous populations from Panama: Ngöbé, Kuna, Emberá, and Wounan (Ascunce et al. 2008). Ascunce and colleagues found that the four tribes shared the typical Amerindian haplogroup Q-p36, and only two Wounan men had the R-P25 haplogroup of European intrusion. All four populations showed high degree of differentiation among them at both the Y-chromosome and the mitochondrial level. The population structure of these populations is the result of the reduced gene flow between them, despite their linguistic relatedness and geographic proximity. These findings contradict previous interpretations of the non-existence of genetic structure at the NRY level by Kolman and Bermingham (Kolman and Bermingham 1997).

Melton (2008) investigated the Y-chromosome gene diversity of eight STRs and corresponding SNPs in five Chibchan speaking populations from Nicaragua (Rama) and Costa Rica (Maleku, Ngöbé [Guaymí], Huetar, and Chorotega). This data was compared with 17 Central and South American populations. Y-chromosome lineages present among the five SCA populations include the Native American haplogroup Q and Q3, European derived haplogroup R1b, G2a, and I1b, and the African haplogroup E3. The study also found a close relationship between Chibchan-Votic populations from Northern Costa Rica and Southeast Nicaragua (Rama, Huetar, and Guatuso) to Mesoamerican Pipil from El Salvador populations, whereas Chibchan-Isthmic speakers (Huetar, Bribri, Guaymí -Abrojo-, Cabecar and Teribe) are related to South American populations. AMOVA analysis of Y-STRs data indicates significant genetic differentiation of male lineages within populations ( $F_{st} = 0.204$ ) and within groups ( $F_{sc} = 0.158$ ), but not among South American, Mesoamerican, and Chibchan groups. This suggests a high degree of gene flow among males from Central America. High Y-chromosome variation values among Chibchan populations are related to two major demographic events: first, the

movement of Mesoamerican populations from Central Mexico with the rise of the Toltec empire around 1200 YBP; and second, the arrival of European populations and other foreign ethnic groups at the beginning of the 16<sup>th</sup> century. In addition, the author did not find significant correlation between Y-chromosome and mtDNA.

### *Autosomal Markers*

In order to study the initial peopling of the Americas, 678 autosomal microsatellite markers were analyzed from 24 Amerindian populations (Wang et al. 2007). The analysis included Chibchan and Paezan speakers. In general, this study proposed a single migration entering the continent and moving southward along the Pacific coast. This hypothesis is supported by the high frequency (36.4%) of the allele D9S1120 among Amerindians and the decrease in genetic diversity from the Bering Strait. Other findings were a relative lack of differentiation between Mesoamerican and Andean populations, and a close relationship between Cabecar and Guaymí populations from SCA with populations of eastern South America. Future studies will need to clarify whether these relationships were caused by ancient or more recent population events (Wang et al. 2007).

Contrary to the scenario of a single migration with subsequent tribalization of Native American populations, Reich et al. (2012), in a study based on 364,470 SNPs of 57 populations, proposed that extant Native Americans descend from at least three migratory events that were defined in Greenberg's linguistic hypothesis (Greenberg et al. 1986). According with Reich and associates, after the initial peopling of South America 15,000 YBP, Chibchan speakers from SCA experienced a reverse gene flow resulting from "recent migrations [that]... contributed most of these populations' ancestry" (Reich et al. 2012: 373). This new evidence and future

genetic studies will elucidate the most parsimonious population history of the Chibchan populations.

### **Pharmacogenetics**

Pharmacogenetics investigations in SCA have studied differences in metabolic pathways that affect individual responses to drugs (Klotz 2007). The response to drug oxidation varies among different ethnic groups as a consequence of human evolution, thus several genetic polymorphisms have been identified and their clinical relevance established (Bertilsson 1995; Gut et al. 1986). A common study of genetic variation of drug oxidation is a test for the absence or deficiency of cytochrome P-450, an isozyme that is related to the debrisoquine/sparteine type polymorphism, a major determinant of therapeutic and toxic responses to a variety of important drugs (Gut et al. 1986).

In order to understand the genetic micro-differentiation of SCA populations, pharmacological research has been conducted to discover the frequency of drug metabolizers in various SCA groups. Clinical tests were given to two Chibchan speaking populations, the Kuna and the Ngöbé from Panama (Arias et al. 1988a; Arias and Jorge 1989; Arias et al. 1988b; Jorge et al. 1993; Petersen et al. 1991). These studies found that the Kuna are deficient metabolizers of sparteine, which may possibly be due to their evolutionary divergence from other SCA populations (Arias et al. 1988b), whereas the Ngöbé showed a microevolution for the sparteine metabolic pathway (Arias et al. 1988a; Arias and Jorge 1989). It has been established that the cytochrome P-450 mediates the metabolism of debrisoquine and sparteine which in turn is associated with several RFLP patterns involving the CYP2D6 gene. Petersen et al. (1991) found that the Bam HI, a polymorphic variant, was correlated to the enzyme deficiency present in poor

metabolizers (PMs) in the Ngöbé population. The study also suggests that this RFLP might represent a founder effect that has occurred in this Amerindian tribe between 20,000 and 30,000 YBP. This metabolic variation is consistent with their demographic history and population genetics (Jorge et al. 1993). Arias et al.(1988a) also suggest that after the divergence of these two populations, selective pressures acted differently resulting in a decrease or an increase of PMs. This may be caused by the food adaptation of the ancestral Kuna to more forested areas, and by the adaptation of the Ngöbé to savanna-like environments.

Figure 9 summarizes the most relevant pre-Columbian and historical events responsible for shaping the population structure of Chibchan speaking groups in SCA according to the information provided in this chapter.

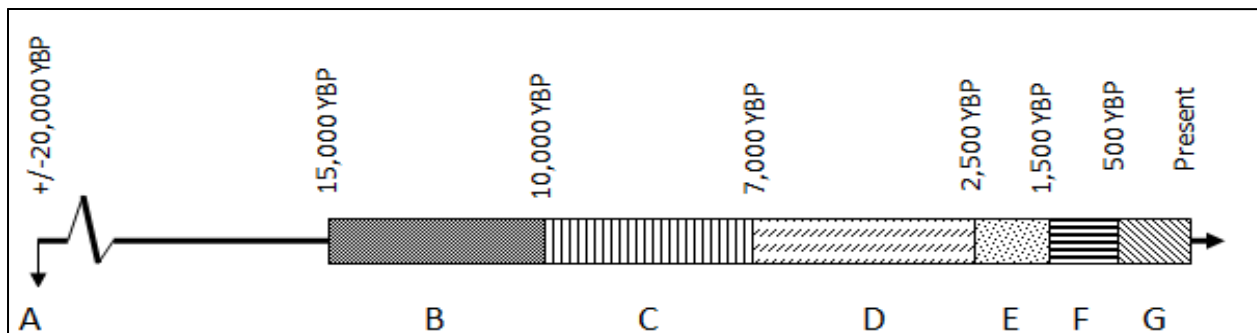

A. According to mtDNA and Y-Chromosome evidence, the peopling of the Americas occurred by migrations along the Pacific coast of North America and South America. The entrance to the Americas caused a major bottleneck during human expansion outward from Africa as well as the spread of the private polymorphism D9S1120 and haplogroups A, B, C, D and X.

B. Late Pleistocene/early Holocene: Initial settlement and dispersal of small and mobile groups (Paleo Amerindians) across the Isthmus. Evidence of Clovis-like and other techno-complexes. Extinction of megafauna and dramatic environmental changes occurred.

C. Stabilization of coasts and colonization of Holocene fauna and flora. Transition from hunter-gathering to early agriculture. Early evidence of plant manipulation (incidental domestication) and environmental disturbance. Fragmentation and geographic isolation of Chibchan speaking populations in SCA. Period in which groups evolved into Chibchan speaking tribes and accumulated unique genetic variants. Possible separation of the Proto-Lenca, Proto-Misumalpa and Proto-Chibchan (Proto-Lenmichí) in Central America followed by the migration and isolation of splitting populations to northern South America. The exposure to different environments and diets of some Chibchan populations resulted in the evolution of characteristic metabolic pathways.

D. Demographic growth and complexity of Chibchan populations (proto-Guaymí, proto-Talamanca, proto-Kuna, etc). Emergence of specialized plant domestication, agro-ecology, and pyrotechnology. Evidence of regional symbolic expressions on ceramics and tool kits for different purposes (cultural zones).

E. Origin of complex social organizations and stratification (*cacicazgos*), as well as specialized agriculture. Diversity of material culture and symbolism. Regional cultural identity is represented in different media such as architecture, sculpture, and ceramics. Possible coexistence and continuation of other types of social organizations and networks.

F. Sociopolitical organization is linked to kinship. Sophistication of ritual and symbolic expressions. Intensive agriculture, hunting, fishing and marine exploitation (mollusks, fish). Evidence of domesticated animals (dogs, turkeys). Settlement and nuclearization and consolidation of *cacicazgos*.

G. Slavery, war, and epidemics associated with European conquest caused population bottleneck. Population growth and admixture occurred after the 18th century with other non-Amerindian populations (Europeans, Africans, and others).

Figure 9. Time chart of biological and associated historical events among Chibchan speaking populations from Southern Central America.



## ***SUMMARY***

The development of studies on human diversity in relation to demographic changes experienced in SCA has followed historical trends, from the emphasis on the classification and description of human types to the modern studies of genetic micro-evolution. The information obtained through anthropological research is largely in agreement about the possible co-evolution of language, culture, and biology of indigenous populations of SCA since their geographical isolation after the late Pleistocene epoch. In addition, the bulk of the most recent studies use genetic data for modeling possible scenarios of migration to the Americas and very few of them pertain to understanding the causes and the genetic consequences of recent historical events or the effect of sociocultural practices on the genetic makeup of existing indigenous populations.

Biological anthropologists, ethnographers, and archaeologists have been increasingly interested in studies on human diversity and demography of SCA; however, the understanding of the demographic changes has been largely deductive as evidenced by cultural ecological and evolutionary-diffusionist models, or has been based on ambiguous sources of evidence (e.g diffusion of ceramic styles).

Before demographic studies had a scientific emphasis in SCA, the colonial and postcolonial administrators were responsible for gathering demographic data. Despite the disagreement among researchers on the size of the SCA population, colonial records verify the impact of diseases, economics, and political activities on the decrease of indigenous populations. Furthermore, demographic information has been largely based on the reevaluation of colonial documentation from the Pacific lowlands and highlands of SCA where sources were historically more abundant compared to the Caribbean region.

The following chapter will provide more in depth ethnohistorical, biological, and ethnographical information on the Rama in the Caribbean region of Nicaragua.

### III- THE RAMA AMERINDIANS

As a continuation of the preceding overview of the Chibchan human geography of SCA, this chapter provides the general background on the origin, culture, economic activity, and demographic changes of the Rama in the Caribbean Nicaragua (Fig.10). In order to document the genetic structure of the Rama caused by recent demographic events, the information provided here is supplemented with personal observations from three field seasons (Baldi 2007/2009) and supplemental ethnographic accounts from literature.

Geographically, Nicaragua is divided in three main zones: The Pacific lowlands, the highlands, and the Caribbean that in turn is separated in two autonomous regions, the Northern Atlantic Region (RAAN) and the Southern Atlantic region (RAAS). RAAS starts at the Matagalpa Rio Grande in the north and it extends as far as Rio Indio in the South, it has a territorial extension of 27,260.02 Km<sup>2</sup> subdivided by nine *municipios*. The Rama territory is located between Bluefields, the most important port and *municipio* of southern Nicaragua, and San Juan de Nicaragua (Greytown) (INIDE 2008b).

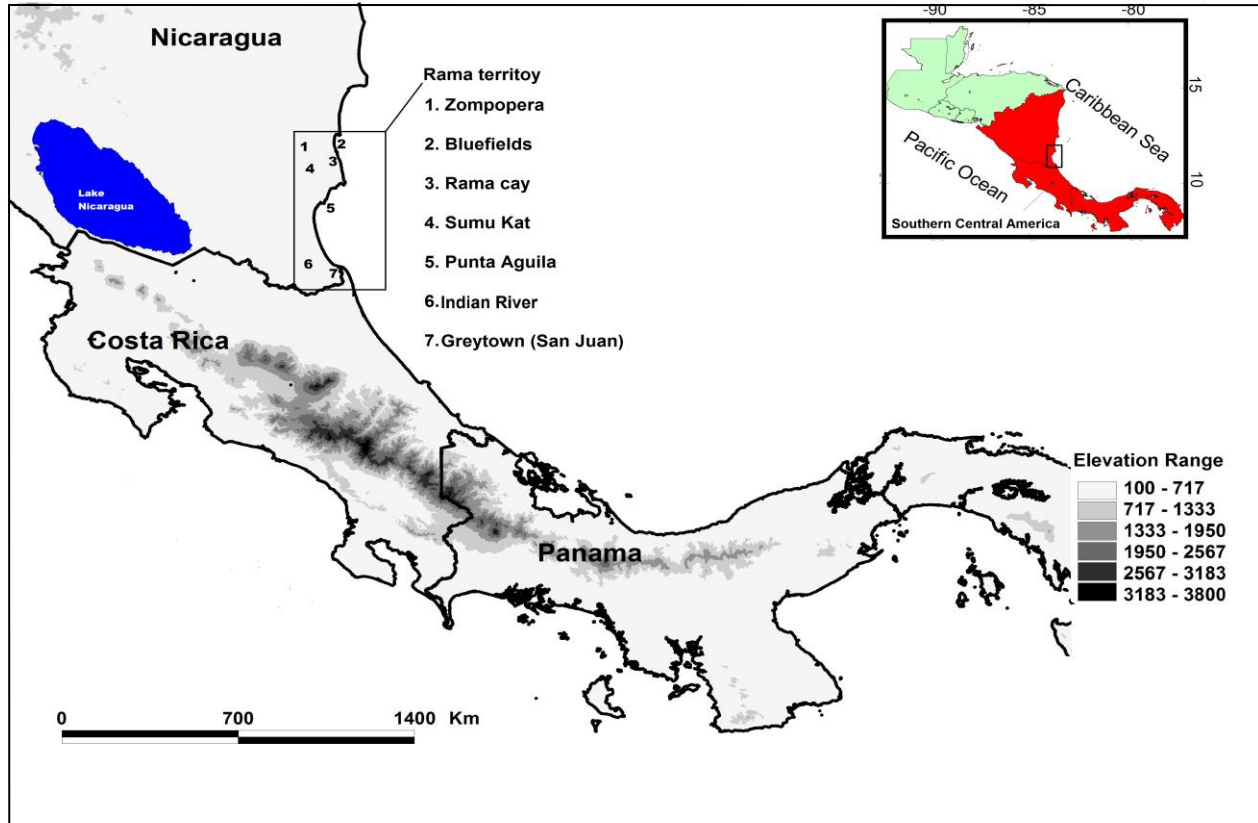

Figure 10. Rama territory and visited communities during fieldwork (2007/2009).

### ***SOCIO-CULTURAL AND DEMOGRAPHIC CHANGE***

Three important forces of socio-cultural and demographic change have affected the Rama: first, European colonization between the 16<sup>th</sup> and 19<sup>th</sup> century; second, the forced acculturation carried out by the Moravian Missionaries; and third, the expansion of the agricultural frontier and the market economy of the 20<sup>th</sup> century. Each of these factors will be discussed in the following sections.

## **European Influence in the Nicaraguan Mosquitia (16<sup>th</sup> - 19<sup>th</sup> centuries)**

The eastern Caribbean coast between Trujillo in Honduras, and Matina in Costa Rica, was discovered by Columbus in 1502. This was followed by continuous European settlement on the Caribbean coast of Nicaragua from 1631 when British colonists established commercial relationships with diverse ethnic groups. The exchange of European goods with Amerindians began in Cape Gracias a Dios and intensified in the following decades. Between 1640 and 1700 these commercial affairs led the British colonists to expand their influence in several parts of the Mosquitia (Newton 1913).

Among all of the populations located in the Mosquitia at the beginning of the 16<sup>th</sup> century, the Miskito were the most dominant and influential. The political and economic relationships established in 1632 between the Miskito and the Providence Island-based British Puritan colony located off the coast of Nicaragua improved with the integration of Jamaica into the British Empire in 1655, which helped to consolidate these relationships for the following 200 years (Fonseca and Cooke 1993). This period is also known for the increase in pirate attacks against Spanish positions in Central America and elsewhere. In this context, the Miskito acted as middlemen between Europeans and became involved in the trade of natural products and Indian slaves. The geopolitical and military dominance of the Miskito over other indigenous populations allowed them to expand their population, causing rival groups to retreat inland to submit to Miskito power, or to be incorporated into other populations (Olien 1988; Romero 1995).

One of the populations that managed to survive was the Voto or Boto then known by some as the Rama, whose presence in the southern Caribbean coast of Nicaragua and northern Costa Rica was documented as early as the 16<sup>th</sup> century by travelers, merchants, bureaucrats, and

buccaneers (Incer and Perez-Valle 1999; Kemble 1884b; Roberts 1978 [1827]; Romero 1996; Squier 1891).

Scattered information about the Rama is also found in Harrower (1825), Roberts (1978 [1827]), Lehmann (1920), Pim and Seeman (1869), Wickham (1872), and Williams (1815). Other sources concerning the Rama are official documents produced by British and North American geographers, diplomats, and Moravian Missionaries (Bell 1862; Kemble 1884b; Mueller 1932; Von Oerstzen and Wunderrich 1990).

Since the beginning of the twentieth century, anthropological studies regarding local customs, material culture, cultural change, assimilation, and biology as well as other aspects of anthropological relevance, were gathered by various individuals interested in the Rama. Among the most pertinent were Conzemius (1927; 1930; 1932; 1938) Loveland (1975), Nietschmann (1969; 1972; 1974), Schultz (1926), D'Aloja (1939), De Stefano (1970-1971; 1973), and Schneider (1989). These studies highlight the cultural uniqueness and morphological differences of the Rama in relation to other populations from the area, noting their characteristic cultural practices, cosmology, mythology, and social organization (Loveland 1975).

In the 16<sup>th</sup> century, the movement of merchants and troops along the San Juan River was an important disruptive factor for the Voto-Rama and other Caribbean populations. In their efforts to control the area, the Spanish caused changes in settlement patterns, demographic decline, and even the disappearance of populations such as the Suerre. Conflict forced local indigenous populations to flee and relocate in other regions, or to establish commercial or military alliances with the Europeans (Incer and Perez-Valle 1999; Romero 1995). This problematic period continued in the 17<sup>th</sup> and 18<sup>th</sup> century due to the presence of buccaneers of different nationalities, loggers, planters, as well as Miskito Indian demands for tribute. Two

centuries of foreign occupation disrupted the social organization and forced the relocation of Rama communities, causing the outbreak of epidemics and demographic changes. This was especially pronounced in those populations inhabiting the San Juan River and its tributaries, and less dramatic in the Punta Gorda River region (GTR-K 2007).

### **The Moravian Missionaries**

Among the most influential forces of cultural change were the Moravian missionaries from Herrnhut in Saxony, who settled in the Caribbean coast of Nicaragua in 1848 (Olien 1988). This religious denomination was in part responsible for the modification or disappearance of traditional cultural practices among local indigenous groups from the Mosquitia (Bataillon and Galindo 2007). When the Moravians arrived on the island of Rama Cay in the Bay of Bluefields in 1858 some islanders ran away to avoid being baptized, but the majority were converted in a short period of time (Loveland 1975; Schnaider 1989). The missionaries' world view, ethics, and morality contrasted with those of the Rama islanders. Cultural practices such as rituals, infanticide, and polygamy were abolished and delegitimized by missionaries as a way to eradicate "moral aberration and vice" (Jurgensen 1858: 8) and for the attainment of "civilization" (Schneider 1989), the ultimate goal of societies according to the 19<sup>th</sup> century Eurocentric perceptions. In order to reach this goal, the missionaries established a set of strict rules among the islanders. Shamanic practices of the *turmali* were forbidden as well as the consumption of rum and any other intoxicating beverages (Schneider 1989). The Rama language was abolished and English was promoted. In addition, the missionaries influenced the architecture, traditional clothing, and child rearing practices (Loveland 1976; Mueller 1932; Nietschmann and Nietschmann 1974). Other rules were reinforced in order to control the population at Rama Cay

and prevent intermarriage with other non-Ramas, for example, Amerindians born outside the island were not permitted to live at Rama Cay or to leave the island without permission, nor were outsiders permitted to visit. Movement remained fluid among Rama communities despite these efforts to control it on Rama Cay (GTR-K 2007).

### **Market Economy of the 20<sup>th</sup> Century and Expansion of the Agricultural Frontier**

In the context of the exploitation of natural rubber in southern Nicaragua between 1880 and 1930, banana plantations were established at El Rama, Bluefields, and Kukra River regions. US companies such as Bluefields Rama Banana and the United Fruit Co. controlled banana production and mahogany lumber operations at Punta Gorda River. For this reason some families relocated to Rama Cay in order to avoid epidemics, physical abuse, and the loss of territory (GTR-K 2007; Riverstone 2004). Despite their relocation, the Rama population was affected by cholera (1901, 1904, and 1907), measles, (1902, 1925, and 1940) and yellow fever: people under 20 years of age and the elderly were the most impacted. Epidemic cycles occurred between August and November each year with the hurricane and rainy season (GTR-K 2007; Moravian-Church 1858-2009)

Between the 1930s and the Second World War, logging and banana companies from western Nicaragua and the US expanded their commercial interest in the Caribbean lowlands, causing a new influx of migrants (Mordt 2002). In the 1960s, the colonization of Caribbean lands from the west was coupled with their privatization, resulting in the transformation of forests into cattle ranches and banana plantations. The presence of new land owners and the privatization of segments of the Rama territory restricted movement across the region. These settlers avoided hostilities with their Rama neighbors; however, they were responsible for the majority of the



reduction of forests and associated resources due to their agriculture practices. A more hostile migration from the west occurred after the 1970s and in subsequent years as a result of the Sandinista's agrarian reform (GTR-K 2007). Multiple authors agree that these events added to the displacement of Rama populations (Muller 2001; Riverstone 2004; Schnaider 1989). For example, to Zompopera and Rama Cay (GTR-K 2007).

The advancement of the colonists continued in the mid 1980s when the Caribbean region was part of the combat front between the Sandinistas and the Revolutionary Democratic Alliance (ARDE). In fact, during the 1980s and the 1990s, migration of poor peasants (*campesinos*) accelerated, resulting in less available land for hunting, fishing and other Rama subsistence activities (Riverstone 2004). All these migratory events caused important changes in co-residence patterns, subsistence and reciprocity systems, language, and the Rama's belief system (Loveland 1975; Schneider 1989). For this reason, new institutional forms of political representation have emerged, such as the Rama and Creole Regional Government (Gobierno Regional Rama Kriol, GTRK), in order to legislate and look after indigenous land rights and emerging proposals of large scale transportation projects and foreign tourism developers, as well as to combat drug trafficking, and physical violence against the Rama and the neighboring Creole population at Monkey Point (Riverstone 2004).

## ***RAMA ORIGINS AND CULTURAL NICHE***

### **Origin of the Rama**

There are at least two major hypotheses that account for the peopling of the Caribbean coast of Nicaragua. The first hypothesis stated that migrants from Panama and Colombia populated this region around the 11<sup>th</sup> century (Conzemius 1932; Floyd 1967; Lehmann 1920),

the second hypothesis claims that in the formative period (~4000 YBP) an early Chibchan migrants came from North America and populated the central highlands and later the Caribbean lowlands (Chapman 1958; Smutko 1988). In the context of these proposals the pre-Columbian origin of the Rama remains uncertain, and conflicting historical accounts compiled by different sources are contradictory (Riverstone 2004; Smutko 1988). Some link the archeological evidence from the Caribbean coast with the Rama (Incer 1975; Riverstone 2004), others, with the above migrations from Mesoamerica or South America (Clark et al. 1984; Conzemius 1938; Magnus 1974; Stone 1972). Other hypotheses state that the Rama are the resulting amalgamation of a number of disparate groups from southern Nicaragua and Northern Costa Rica or are perhaps the direct descendants of extinct Voto that inhabited the northern region of Costa Rica in the colonial period (Riverstone 2004).

In the 16<sup>th</sup> century, the indigenous groups inhabiting the northern lowlands of the Caribbean region of Costa Rica, including those found along the San Juan River and its tributaries between Costa Rica and Nicaragua were encountered by Spanish conquistadors, who named them Votos. Martin de Estete was the first Spaniard to come across this group in the northern lowlands and the San Juan River in 1529. Expeditions in 1560, and again in 1638 and 1639, by Hernando de Sibaja and Jeronimo Retes, respectively, were unsuccessful campaigns for conquest the Caribbean region. A less favorable scenario was experienced by Amerindians inhabiting the Pacific lowlands and highlands of Costa Rica and Nicaragua at this period (Solorzano 2000).

According to Solórzano (2000), the colonization of lands belonging to the Voto and other groups slowed in the 16<sup>th</sup> and early 17<sup>th</sup> centuries due to extreme humidity, poor logistics of the Spanish, and indigenous alliances against foreign incursions. The dense forests, labyrinthine

tributaries, and extensive wetlands of the San Juan River might have served as refuge from Spanish oppression for those Indigenous groups who left the highlands of Costa Rica, and possibly stretches of western Nicaragua; slowing down the forces of acculturation, preserving political and economic structures, and providing a certain degree of protection from the spread of European diseases (Solorzano 2000). A number of these groups, the Tises, Katapas, Abito, Pocosol, Tori, and Nahua among them, appear in ethno-historical accounts that provide a glimpse of the human geography found along the San Juan River and surrounding areas at the eve of the Spanish conquest (Ibarra 2011b; Solorzano 2000); however, the ambiguity of the chronicles contributes to the difficulty faced by historians and anthropologists who wish to identify population names and localities. For example, the name Rama first appears in the 18<sup>th</sup> century and it was applied to the same group of people who had been called Voto in previous accounts (Conzemius 1938; Ibarra 2011b; Riverstone 2004; Solorzano 2000). Yet direct ancestry between the Voto and Rama is not widely accepted, and some believe that the group referred to as the Rama in this period was a blended group made up of a number of disparate populations such as the Guatuso, the Suerre, the Huetar, the Corobici, or the Melchora, who combined in the so-called San Juan River indigenous refuge while escaping European colonization, which would indicate that the Rama of today are an amalgamation of groups (Riverstone 2004). The confusion is increased since the name Rama was used interchangeably with a number of other names during the same time period. Don Diez Navarro, a Spanish visitor to the San Juan River in the 1740s, stated that whether or not some individuals can distinguish between “Caribs” (Rama) or “Moscos” (Miskito), in his estimation they all belong to “the same nature”(Romero 1995). Rama, Mosco, wild (*salvajes*) and assimilated (*mansos*) Caribs, and possibly others account for this variation that ultimately blurs historical continuity and creates confusion. It is important to note

that the name Carib was applied to the Sumo and Matagalpas from the midlands and lowlands of the Caribbean Nicaragua, as well as to the Rama. The name Voto, widely disused in the northern lowlands of Costa Rica in the 18<sup>th</sup> century, was the identifier given to the Amerindians inhabiting the Punta Gorda River according to the field marshal Pedro de Rivera in 1742 (Incer 1975). In the 18<sup>th</sup> century the name Rama gained wide use in maps and chronicles by Englishmen such as Robert Hodgson and Edward Long (Schneider 1989). In subsequent centuries more information about the Rama appears in historical accounts, making it possible to reconstruct other aspects of the genetic impact caused by migrations, disease, and culture change.

Based solely on ethnohistorical accounts, the above hypotheses of origins are difficult to test because of the existing discrepancy of locations, the complexity of population movements, the assimilation process, and the overlapping of cultures and names of the indigenous villages in the sixteenth century and later.

### **Residence Relocation and Demography**

Rough population figures have been reported since the 18<sup>th</sup> century (Table 4). Some of these records were collected in specific places such as Rama Cay and did not account for the less accessible settlements in the south. The residential mobility of the Rama within their territory makes it difficult to estimate the true population size through different periods.

Table 4. Documented population figures of the Rama

Year	Total	Rama Cay	Other villages	Reference
1700s	~1300	?	?	(Lehmann 1920)
1816-1817	500	?	?	(Roberts 1978 [1827])
1841	580	80	500	(P.R.O.F.O 1841)
1857	?	150/170	?	(Conzemius 1927)
1862	200	?	?	(Bell 1862)
1868	?	164	?	(Wickham 1872)
1909	285	?	?	(Lehmann 1920)
1922	270	220	50	(Conzemius 1927)
1968	525	390	135	(Nietschmann and Nietschmann 1974)
1975	?	385	?	(Loveland 1975)
1980	649	?	?	(Grinevald 2003)
1992	1328	566	772	(Hodgson et al. 1993)
1998	?	800	?	(Ordonez et al. 1998)
1999	1200	800	400	(Muller 2001)
2000	1100	?	?	(Grinevald 2003)
2005/2007	1423	785	638	GTRK 2007
<b>2009</b>	<b>1430</b>	?	?	<b>This study</b>

Forced displacement by European landholdings and Miskito traders between 1816 and 1820 contributed to high mortality among the Rama and other indigenous groups of South Nicaragua (Olien 1988), but the largest known Rama community, Punta Gorda, survived after being temporarily abandoned in the 1770s (Roberts 1978 [1827]). Unfortunately, there are not known records of the population numbers. Between 1816 and 1817, Orlando Roberts counted around 500 Rama individuals living in communities between the San Juan River and Bluefields. However, this merchant did not mention the other two populations in existence during the 19<sup>th</sup> century: one located in the Rio Kukra region and a group of dispersed populations further south. Among them, the population at Rama Cay is of the most recent aggregation, the most visible today, and where most of population censuses are made (GTR-K 2007).

At the end of the 18<sup>th</sup> century and the beginning of the 19<sup>th</sup> century, a group of Rama that inhabited Rio Escondido and the Punta Gorda River region moved to Rama Cay at the Bay of Bluefields (GTR K 2007). The oral tradition compiled by the Moravian missionary Jen Poulsen Jorgensen (Loveland 1975) along with Edward Conzemius' ethnography (1927) state that a this group moved to Rama Cay after being compensated by the Miskito kingdom for services rendered in an intertribal war against the Teribe from Costa Rica.

The subsequent influence of the Creole, Mestizo, Europeans and other indigenous populations, led to the acculturation of the Rama and the development of different world views. Some traditions vanished or transformed, while other material and immaterial elements of the culture, such as some technologies and subsistence practices, have survived to the present day.

### **Social Structure**

Romero (1995) compiled a number of historical references of the economy and social organization of a number of groups inhabiting the Caribbean in the 17<sup>th</sup> and 18<sup>th</sup> centuries. Among these, the Rama-Carib was characterized by a social organization defined as *parcialidades* by the Spanish. *Parcialidades* were groups of families linked by kinship and spread through the territory and along rivers. They were comprised of individuals and extended families fluctuating from fewer than 40 to around 300 separated by 40-50 km on average. Groups of families inhabited large huts made of wood and palm leaves near small horticultural plots and polygyny was the predominant mating system. Like today, in the 17<sup>th</sup> and 18<sup>th</sup> centuries some families temporarily abandoned their houses after harvest and established homes in a different location along the rivers. Fish and game were obtained in the vicinity and from the sea. Residential mobility the Rama-Carib way of life might have protected them from location by

colonizers, slowed the propagation of infectious diseases, and concealed them in the forest for long periods of time. This group was known as excellent navigators whose boat designs allowed them access to rivers, lagoons, or the sea. In case of conflict with colonizers, these *parcialiades* were united by a “big man”, called *capitan* by the Spanish, who would lead the fight against enemies. When conflicts ended, the temporary social stratification that divided big men from the rest of the population returned to the egalitarian normality (Romero 1995).

Following the sixteenth century, dispersed settlement patterns began changing into nuclear aggregations of houses. The forced aggregation of the Rama, caused in part by the British, contributed to the increase in mortality and the population decline that resulted from the epidemics and conflicts that continue today (GTR-K 2007). Before the end of the 19th century, settlements were typically comprised of 2-3 extended families or *caserios* of fewer than 70 individuals scattered throughout the territory (Conzemius 1927). Despite these changes, scattered houses still persist along some rivers.

Household, kinship, and the relationship between sexes were, according to Loveland (1975), the most important elements for the function of the social structure and organization among the Rama. In the 19<sup>th</sup> century, households were constituted of both parents, unmarried and married children, and their spouses (Jurgensen 1869 [1894]). Matrilocal residence was predominant and persists today (Fig.11). In the recent past, autonomous economic groups of kin known as *Kuanu*, each composed of around 21 members, facilitated the sharing of resources and services between family units (GTR-K 2007; Loveland 1975). Today, this pattern of affinal aggregation and vicinage is not random because it is based on generations of arranged marriages (explicit or not) with other known family groups (cf. Loveland 1975). When members of families

split from a community, they maintain strong relations through networks that can be extended over dozens or hundreds of kilometers.

Endogamic marriages are encouraged among members of the group (Nietschmann and Nietschmann 1974), however, mixed marriages have been increasing in recent years, especially between non-Rama men and Rama women. Children conceived within these mixed marriages are perceived as Rama (GTR-K 2007).

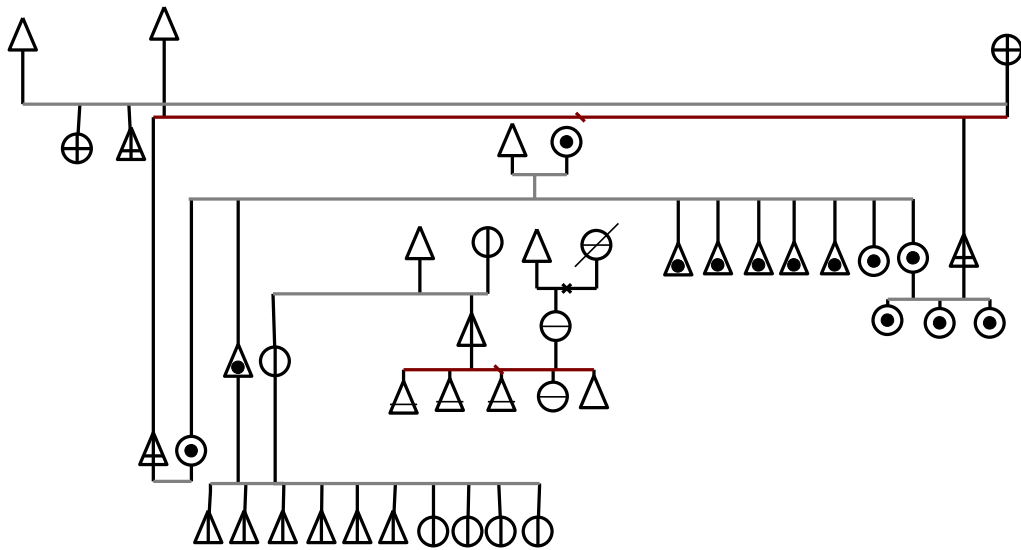

Figure 11. Kinship representation of a local group after fission from Rama Cay and other communities. Local groups include matrilineal family units, represented by same symbols. Married daughters and unmarried children remain within a family unit.

Families often own three different types of houses and move between them seasonally (multilocal residence). The houses may be open, walled, or built on pilings. Open houses have silico palm-thatched (*Raphia taedigera*) roofs and floors made of chonta (*Socratea durissima*) and are found along rivers near agricultural plots and hunting places. Walled houses often have



compact earth floors and rooms dedicated to sleeping, cooking and eating, and other activities. Pilling houses are located in flooded areas and they have separated rooms and wooden floors. Houses are constructed collectively by household members and friends (cf. Conzemius 1927; Loveland 1975; Nietschmann and Nietschmann 1974). At Rama Cay, Punta Aguila and Greytown, for example, houses are made of a combination of traditional and non-traditional materials such as zinc roofs. Because Rama Amerindians are a semi-sedentary group, having different houses facilitates their movement around their territory and their performance of different activities such as hunting, fishing, agriculture, and networking.

In contrast to the scenario of separated family units along the rivers, contemporary familial concentration in communities is understood as a social adaptation against recent land-invasions, forced displacement, and pressure caused by the expansion of the agricultural frontier. These forces have restricted the mobility of individuals within the territory while providing protection to the group as a whole, although traditional patterns of socio-territorial structure persist (GTR-K 2007).

### **Origin of the Rama Surnames**

Rama surname transmission follows the Iberoamerican surname system (IASS) in which every individual inherits two surnames, “the first surname is the first surname of his or her father, and the second surname is the first surname of his or her mother” (Pinto-Cisneras et al. 1985: 274). This system of transmission was confirmed through genealogical reconstructions.

Rama Amerindians inherited their current surnames as a result of the increasing influence of British buccaneers and Creole merchants since the eighteenth century in the Caribbean coast, before their relocation into villages such as Rama Cay in the nineteenth century, when Moravian

missionaries established the rules of surname transmission in an effort to ensure monogamous relationships. For example, individuals resulting from illegitimate unions only held their mother's last name in church records (GTR-K 2007). In the past, the majority of families had British family names as shown in Moravian records at Rama Cay (Moravian-Church 1858-2009). More recently, Spanish and Creole family names have become frequent.

### **Language and Cosmography**

Linguistically, Rama belongs to the Votic subdivision of the Chibchan linguistic family of Central America (Constenla 1991; Lehmann 1920). The Votic linguistic family includes the geographically related Guatuso and the extinct Corobici and Huetar from central and northern Costa Rica; however, this linguistic family is also closely related with the Bari and Chimila from Colombia, and somewhat less so with other geographically close Chibchan speakers from Costa Rica, excepting the Teribe from Bocas del Toro in the Caribbean Panama (Constenla 2008). This situation has been a challenge in the quest to understand the relationship of the different Chibchan languages and their migratory history (Grinevald 2003).

According to different surveys, fewer than 50 fluent Rama speakers are left. The reduction of the number of Rama speakers was accelerated by the presence of Moravian missionaries in Rama Cay who promoted Standard English as medium for Christian conversion, education, and linguistic prestige. However, the exposure to Creole-English and Miskito speakers from the coast created a new variant of the Miskito Coast Creole called Rama Cay-Creole (RCC). This new linguistic variant, spoken mostly in Rama Cay, significantly differs from others on the coast because it has borrowed words from English, German, Miskito, Rama, and has a grammatical particularity. The Creole spoken by the Ramas south of Rama Cay is also

different (Assandi 1983). In order to preserve the Rama language from extinction, different initiatives have been developed such as the creation of dictionaries and Rama language classes in schools (Craig et al. 1986; Grinevald 2003).

Table 5. Cosmography of the Rama according with Loveland (1975)

Axis	Geographical location	Associated Resources	Mythical elements
<b>North</b> 	8) Bay of Bluefields and Rama Cay	“Creation crops”, wari (white-lipped peccary), stone metates	Jaguars drove the Rama to Rama Cay. An <i>Ulak</i> , <i>Sirkin</i> , and wari gameowner protects game. <i>Sirkin</i> in Kukra River.
	7) Wiring Cay		Adam’s ship
	6) Monkey Point		Adam’s cannons
	5) Cane Creek		<i>Waksuk</i>
	4) Punta Gorda Bar		Adam’s ship
	3) Punta Gorda River	(Known as Rama homeland)	Adam feats
	2) Snook Creek	Salt, vacations (pick nick), gathering ahi (sand clams), hunting wari	<i>Waksuk</i> , <i>Turmali</i>
	1) Corn River	Hunting manatee, chocolate, corn, cane, cassava, banana	<i>Kulmon</i> spirits
<b>South</b>			

Note: The migration of a fissionated Rama group from Corn River, Snook Creek, and Punta Gorda to the Bay of Bluefields is linked with their mythology.

Among the Rama, language serves as a “medium of culture and social practice” (Schneider 1989: 17) and, as in any other human society, language helps to domesticate the physical environment through symbolisms that are expressed in myths and mental maps of the territory (Rapoport 2002). According to Loveland (1975), the Rama incorporated the history and the geography of their migration from Punta Gorda to the Bay of Bluefields in their mythology.

Table 5 shows mythological elements associated with places, and economic activities associated with this migration that, according to Schneider (1989), date back to the 18<sup>th</sup> century.

These myths contain a great deal of Christian syncretism which can be interpreted as a product of such foreign influence. In general, reconstructed mythologies by Loveland (1975) pinpointed Corn River, Snook Creek, Cane Creek, Monkey Point, and the Punta Gorda region as localities where Rama emerged before their migration north to the Bay of Bluefields. Corn River was a region suited for horticulture of local (chocolate, corn, cassava) and exotic products (banana, sugar cane?). In this place a *kulmon*, a mythical figure that helps people, inhabited the river rocks near headwaters of rivers. At Snook Creek, where hunting and gathering were carried out, herds of destructive imaginary jaguars, or *waksuk*, moved through the primary forests (*sulaik*). In this place, the *turmali*, or shaman, is the human figure that protected the Rama from those evil spirits (*waksuk*). Adam, the mystical hero of the Rama, established the first contact with buccaneers in the Punta Gorda region, Monkey Point, Wiring Cay, and Cane Creek. This is reflected in the story's European elements of ships and cannons. According to Rama mythology, the last migration occurred when the Rama people were driven by imaginary jaguars to Rama Cay, where they cultivated the land (creation crops), hunted (*wari*) and used stone tools such as metates. At Rama Cay, it was thought that numerous spirits co-existed in mangroves, lagoons, and rivers, such as the *ulak* and the *sirkin* for protecting game.

### **Niche Construction and Means of Subsistence**

The southern Mosquitia is one of the rainiest regions of the world; the average annual rainfall can reach nearly 20 feet of water per year (6000 mm). The region is characterized by year-round rain with a drier period that fluctuates between February and March, and April and

May (Riverstone 2004) (Fig.11). A heavy rainy season (*siuu tuka*) with storms and periodic flooding occurs between June and July. October is when most of the hurricanes hit the coast and cause coastal modifications, the outbreak of diseases, starvation, and human fatalities (Nietschmann 1973; Offen 1999; Romero 2007).

In the lowland tropical forest and wetland ecosystem, known as *sulaik* by the Rama, game and plants for multiple uses are obtained. In addition, the coast, lagoons and mangroves are important spaces for hunting and gathering small animals, shellfish, reptiles, and fish. Lagoons and swamps cover extensive parts of the territory, and lower courses of rivers shelter the West Indian Manatee (*Trichechus manatus*), an important source of protein and significant mythological creature for the Rama (Riverstone 2004).

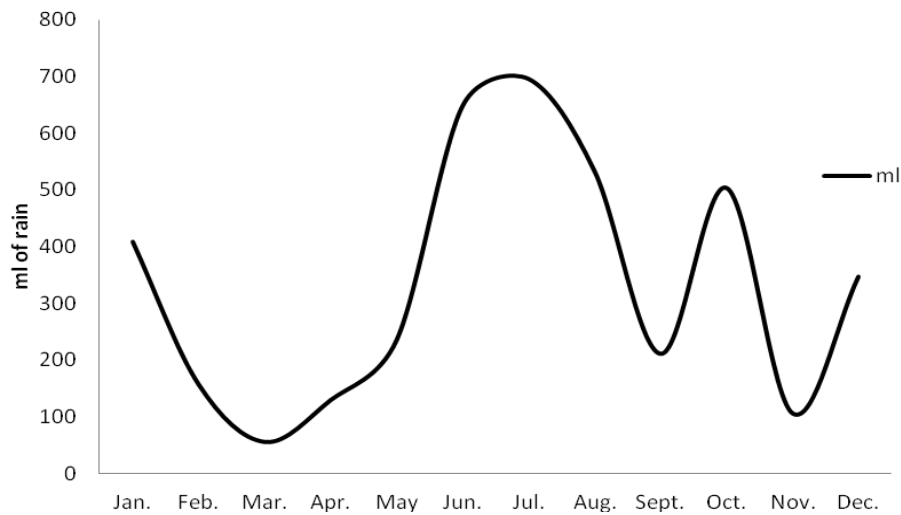

Figure 12. Annual rainfall in the southern Caribbean region of Nicaragua in 2008 (INIDE 2008a).

Eyewitnesses who interacted with the native populations in the lowlands and on the coast of the Caribbean Nicaragua at the eve of the European conquest described an indigenous social organization that may be categorized as a semisedentary group subsisting as hunters, gathers,

horticulturalists, and fishermen (Romero 1995; Romero 1996). Over generations, the Rama have developed a number of economic activities that are related to the annual cycles of nature (Table 6), although part of their subsistence does rely on manufactured foods (Riverstone 2004). The division of labor by sex and age allows the functionality of the family system and their survivorship. The labor force is mostly designed to nurture families and little of the fishing and agricultural production is sold in the markets. The Rama have no private property, therefore, cultivation and other activities such as house construction are done collectively. Men, women, and children participate to sustain the economic structure of the family unit (Loveland 1975; Schnaider 1989).

Economic resources and the seasonal mobility of families are in part determined by the ecological cycles. Migrations within the territory allow the Rama to take advantage of seasonal products such as shrimp, fish, marine turtles, iguanas, and planting and harvesting. Transportation within the territory is mostly done by canoe (*dori*) and less frequently by motor boat. Some of these canoe trips on the river can take several days.

Reciprocity and networking is the mechanism that permitted group identity and cohesion. For example, in the recent past, it was more frequent for family units from inside the territory to converge on the coast for shell gathering and other activities, as well as to visit Rama Cay at Christmas time (GTR-K 2007). Reciprocity is an important element of this system because it helps to strengthen social and family networks between distant communities. The author documented individuals bringing presents such as oysters, cassava, plantains, shrimps and other products to family members and friends many kilometers away from their home base.

Table 6. Some hunted and gathered resources observed during fieldwork (2008/2009)

Name	Rama/ Creole name	Species
Brocket deers	Suula sala/red deer	<i>Mazama americana</i>
Green turtles	Uuli/turtel	<i>Chelonia mydas</i>
White-lipped peccary	Ngulkang/wari	<i>Tayassu pecari</i>
River turtles	Paaruk/hicatee	<i>Pseudemys sp.</i>
Oysters		<i>Crassostrea rhyzophora</i>
Cockles	/carckle	<i>Polymesoda sp.</i>
Sand clams	ahi/	<i>Polymesoda sp.</i>
Shrimps	/chacalin	<i>Penaeus notialis</i>
Crabs		<i>Callinectes sapidus</i>
River shrimps		<i>Macrobrachium carcinus</i>
Mojarras	/tuba	<i>Ciclasoma sp.</i>
Red snappers	/red snapper	<i>Lutjanus sp.</i>
Mullets	/califavor	<i>Mugil sp.</i>

### Present-day Rama Communities

Gerald Riverstone (2004) categorized ten areas within the Rama territory. Of these, Rama Cay is situated on the Bluefields Lagoon. Zompopera and El Coco, or Sumu Kat, are located at the middle and upriver of the Kukra River respectively, and the Danuko-Torsuani Rivers flow into the southwestern corner of the Bluefields Lagoon which has an extension of 127.73 km<sup>2</sup> (INIDE 2008a). The Wiring Cay area is located at the Alligator Lagoon, and the Monkey Point is located 45 km south of Bluefields on the coast. Today, this last community is inhabited mostly by Creole families. The Cane Creek/Punta Aguila area is located 7 km south of Monkey Point. The Punta Gorda area is approximately 15 km south of Monkey Point and the Rio Maiz area is 75 km south of Bluefields. The final area is located at Rio Indio. All of these areas include a number of communities and only seven of the most populated were visited during fieldwork.

### ***Rama Cay (Rama Ipang)***

Rama Cay, located 15 km south of Bluefields, is a small island of 0.18 km<sup>2</sup> given a figure of eight shape by two peculiar geological features of basaltic rocks, which are separated by a swamp that has been filled with mollusk shells and other materials by the islanders to serve as a bridge. The north side of the island contains the Moravian Church and the South side, the School, health clinic, electric generator, and a communal center. In the past, inhabitants of both sides have experienced some hostility toward each other (Loveland 1975). Some of this resentment persists today, for example, differences in political and religious preferences were observed during fieldwork. These differences were manifest in the 1980s by family surnames and household clusters linked by consanguinity at the northern and southern part of the island (CIDCA 1993).

There is no public means of transportation to the island. Individuals and families usually sail back and forth between neighboring communities, and especially to Bluefields, the biggest and the most important city on the Caribbean coast of Nicaragua. Occasionally, a motor boat is borrowed but it is an uncommon mode of transportation.

The population of Rama Cay comprises around 50% of the entire Rama population (785 individuals between 2005 and 2007) and has been overpopulated since the Nicaraguan conflict of the 1980s (GTR-K 2007).

The Rama Cay community subsists by fishing in rivers, the ocean, and the Bluefields Lagoon, by hunting and by practicing agriculture in the adjacent forest. Recent decades have seen the areas where the Rama conduct these activities, such as the Kukra, Danuko, and Torsuani Rivers, under the pressure due to the progressive colonization of Mestizo peasants and cattle ranchers from the west (Muller 2001; Riverstone 2006). This has affected the Rama's



subsistence activities and nutrition due to the reduction of their geographical space. For example, fishing and the gathering of oysters and shrimp are becoming more important activities compared to hunting and agriculture (Riverstone 2006).

### ***Bluefields (Punta Fria)***

A few families from Rama Cay and Zompopera own a second house in the poorest and most depressed neighborhood in Bluefields, known as Punta Fria (INIDE 2008b). Having a second house is an advantage, making it possible for family and friends to work, attend school, or spend time in Bluefields.

### ***Zompopera (Tiktik Kaanu)***

Zompopera is located 12 km west of Rama Cay on the banks of the Kukra River. Before its creation, this community was disseminated along several tributary streams of the Kukra River such as the Cuam Creek (*Kungkung Ri*), Curassow River (*Ngaland Ri*), or the Mahogany Creek (*Unsaba Ri*). These areas have all been colonized today by Mestizos who often clash with the Rama over logging, hunting and land invasion (Muller 2001). The increase of settlers has augmented hostilities for land, causing the agglomeration of households in Sumu Kat and Zompopera.

### ***Sumu Kat (El Coco)***

What is known today as Sumu Kat is located 40 km west-southwest from Rama Cay via the Kukra River. The inhabitants of this community utilize the river for fishing, plant crops in fields near the houses, and hunt in the surrounding lands. The surplus production is sold in the Market of San Francisco, a Mestizo town, or in Bluefields.

The Sumu Kat population once extended for many kilometers along the Muelle Real, Santa Elena, and Caño Silver was forced to concentrate as a result of the Sandinista policies after the 1980s that provided support for the establishment of new agricultural cooperatives. The influx of Mestizo settlers pushed the Rama to less fertile lands for agriculture. This process was accompanied by tense conflicts between these two groups (Schneider 1989).

### ***Punta Aguila (Bangkukuk)***

Punta Aguila is located 7 km south of Monkey Point, where a few houses and a school sit atop a hill. This community has strong kinship relations with other communities such as Monkey Point, Cane Creek, Punta Gorda, Pastate and Diamante and is the region where the majority of Rama speakers live (GTR-K 2007).

Fishing and turtle hunting are important economic activities in Punta Aguila due to its proximity to the coast.

### ***Greytown (San Juan del Norte)***

Greytown or San Juan del Norte is close to the political border of Costa Rica and Nicaragua. After the Nicaraguan civil war in 1980s, a number of Rama families relocated to a “Rama neighborhood” in this locality.

### ***Indian River***

Up river from Greytown and near the San Juan Wildlife Refuge is the community of Indian River. This locality was re-populated after the Nicaraguan civil war and is comprised of other communities such as La Cucaracha and Canta Gallo as well as a few scattered hamlets

along the river. This area is known for its rich biodiversity and copious rainfall throughout the year.

### ***SUMMARY***

This chapter provides the ethnohistorical and general ethnographical background of the Rama since the eve of the European colonization of the Mosquitia. The European presence caused major sociocultural, migratory, and demographic changes among this group and other native populations. In order to evade physical violence or pressure for natural resources, some Rama groups who inhabited the southern boundary between Nicaragua and Costa Rica migrated north to the Punta Gorda region in the 18<sup>th</sup> century. A subsequent migration up to the Bluefields Lagoon occurred in the 1848. The Moravian missionaries who came at the end of the 19<sup>th</sup> century had a more active role of acculturation and cultural change with this population than with remaining populations in the south of the territory. Due to the expansion of the agricultural frontier and the economic forces of the market economy, the Rama have recently experienced a significant change in their patterns of agglomeration and spatial distribution. The reduction of their movement across the territory and the escalation of physical violence are causing changes in the Rama's demography and morbidity. All these aspects of population change are important to consider when using cultural information (surname), molecular markers (mtDNA), and vital events, to assert implications on the population structure and demographic analyses.

## **IV- MATERIALS AND METHODS**

This chapter is divided in four main sections: first, a description of the fieldwork and sample collection in Nicaragua; second, the methods used to generate the demographic profile which includes rates calculations on the health, mortality, and fertility of the Rama; third, how marital migration and population structure were calculated based on kinship information; and fourth, laboratory and analytical techniques used to assess the genetic variation of the Rama and comparative populations by means of mtDNA sequencing, RFLP haplogroup characterization, and classical genetic polymorphisms.

### ***SAMPLE COLLECTION***

In July 2007, the author visited the city of Bluefields and Rama Cay in Nicaragua in order to contact Rama leaders and carry out subsequent bio-cultural research. On that occasion, Mr. Cleveland Macrea, the Moravian minister and leader of the Rama Indian community, voiced interest in the project due to its historical relevance for the Rama community. In October of the same year, the author returned with Phillip Melton to carry out field work, collect buccal swabs and mouth washes from 75 participants for DNA analysis, and to compile demographic and ethnographic information from the localities of Rama Cay, Sumu Kat and Bluefields. Data from this sample was included in Dr. Melton's PhD dissertation (Melton 2008). In addition, 75 duplicate specimens and a copy of the University of Kansas informed consent statement was given to Dr. Ramiro Barrantes of the Biology School, University of Costa Rica during our visit to the University of Costa Rica.

In June and July 2009, during the second phase of field research, the author, with the help of University of Kansas anthropology student, Tiago Schaffrath, collected an additional 200 samples from other, previously unsampled villages. The most populated communities along the Caribbean coast, forested lowlands, and upper rivers were visited by motor boat or canoe and geographical positions were taken with a Geographical Position System (GPS) (Garmin GPSMAP 60Cxs). During the field work, a local Rama Indian informant and guide, Mr. Jerry Macrea was hired. Over the course of this second visit, demographic, genealogical, historical and ethnographic information on mode of subsistence, settlement patterns, and mobility across the Rama territory were documented (Table 7), in addition, epithelial cells from participants were obtained through buccal swabs and mouth washes.

Table 7. Study populations of six Rama communities

<b>Community</b>	<b>Males</b>	<b>Females</b>	<b>Total</b>
Rama Cay†	48	77	125
Zomopera	18	21	39
Sumu Kat	14	17	31
Greytown	20	28	48
<u>Indian River</u>			
-Canta Gallo-	6	4	10
-El Encanto-			
Punta Aguila	12	10	22
<b>Total</b>	<b>118</b>	<b>157</b>	<b>275</b>

(†) Includes samples from Bluefields.

Cells from swabs and mouth washes were collected in Cryotubes with 750  $\mu$ L of TE, then 10 mL of distilled water in a clean cup was provided to each participant. After swishing the water for a minute and expectorating back into the cup, the samples were poured into a 15 mL collection tube. Collection tubes were sequentially numbered and placed in a hermetic plastic

box for safe storage in the field. The samples were transported to the Laboratory of Biological Anthropology (LBA) of the University of Kansas for DNA extraction and analysis.

Fieldwork was supported by the Tinker field research grant and the Charles Stansifer Fellowship awarded by the Center for Latin American Studies, University of Kansas. Additional financial help for laboratory supplies and analysis was provided by the Summer Research Fellowship from the University of Kansas and the Carroll D. Clark award from the Department of Anthropology of the University of Kansas.

### **Participant Demographic Questionnaire**

Permission for this study was granted by the University of Kansas Institutional Review Board (IRB) (HSCL # 16735, appendix 1), the Gobierno Territorial Rama y Kriol (GTR-K) from the Región Autónoma del Atlántico Sur (RAAS) of Nicaragua, and local Rama representatives in every locality visited. Every participant older than 18 years was provided with the principal investigator contact details, and then individuals were asked to sign the informed consent statement if they agreed to participate in the study (appendix 2). The questionnaire included information on sex, place and date of birth, age, and genealogical information consisting of number and sex of children, and the maternal and paternal parents (appendix 3).

Before interviews, information about the project was provided in meetings at the Moravian Church, schools, and every household visited. Interviews were conducted in both English and Spanish. Additional help in the interview process was provided by local Rama leaders in most Rama communities visited. At the end of the fieldwork, two copies of Phillip Melton's doctoral dissertation and a presentation of Melton's results were given to members of the Rama community at the Moravian Church facilities at Rama Cay.

## ***DEMOGRAPHIC PROFILE***

For comparative purposes, four different levels of population segregation were included in this study: the *municipio* of Bluefields, the *comarca* of Rama Cay, Rama Cay (includes other Rama communities), and RAAS. This subdivision is based on the Nicaraguan health service system (*Sistema de Atención Integral de Salud-SILAIS*) at RAAS.

The Nicaraguan health service system subdivided RAAS in seven *municipios*: Corn Island, La Cruz de Rio Grande, Bluefields, Karawala, El Tortuguero, Pearl Lagoon, and Kukra Hill. The *municipio* of Bluefields has an extension of 4,774.75 Km<sup>2</sup> (INIDE 2008a) and is subdivided by SILAIS in nine *comarcas*: Juan M. Morales, L. Bracket, J. Gordon, Pancasan, El Bluff, San Francisco, Punta Gorda, Monkey Point, and Rama Cay. The *comarca* of Rama Cay includes the island and the communities of Sumu Kat, Zompopera, Wiring cay, Indian River (which includes Greytown), Yaladina, Torsuany River, Colorado, Grenada, Santa Elisa, Las Cuevas, El Pavon, El Gurrion, and La Cuna (Abraham Mayorga [MINSa], personal communication, 2009).

### **Demographic Structure and Population Composition**

The demographic structure for the Southern Atlantic region of Nicaragua (RAAS) was constructed in Excel using official demographic data from the Instituto Nacional de Información y Desarrollo —INIDE— (INIDE 2008d). The demographic structure of the RAAS and the Rama were represented as a pyramid-type diagram in which bars correspond to percentages of age-sex groups.

Sex ratios for the Rama were calculated dividing the total number of males [A] and females [B] as  $A/B*100$ . If the ratio was equal to 100 the sexes were in balance, if the ratio was less than 100, an excess of females was indicated. The opposite would be indicative of an excess of males.

### **Vital Statistics**

Vital statistics distinguish three basic categories: live births, deaths, and fetal deaths (i.e., fetal losses) and include health, disease, and morbidity (WHO 1950). In order to examine changes in population composition and vital events, different rates were calculated from raw official data provided by the Rama clinic at Rama Cay and by the epidemiologist Abraham Mayorga from the Ministry of Health (MINSAs/SILAIS) in Bluefields, as well as from the demographic questionnaire and the Moravian Church records (Records 1858-2009).

Death rates, mortality, and disease were calculated using official reports from the clinic at Rama Cay and MINSAs/SILAIS data for RAAS, the *municipio* of Bluefields, and the *comarca* of Rama Cay. Rates were divided by total number of cases in a population and multiplied by 1,000, 10,000 and 100,000 in accordance with population size.

### **Death Rates**

A rate provides insight into the frequency of demographic events such as death, migration, and birth. Rates are expressed as crude, general, and specific. Crude rates measure vital events occurring in the whole population. General rates limit events to those persons at risk (total population), and specific rates measure an event among a subset of a population (Kleinman 1977). The vital statistics for mortality analyzed in this dissertation were: crude death rates



(CDR), infant mortality rates (IMR), age specific mortality rates (ASMR), fetal mortality rates (FMR), neonatal mortality rates (NMR), and maternal mortality rates (MMR). Despite their demographic importance, these statistics have limited use for comparison among different populations (Kleinman 1977).

CDR was used as a general indicator of the health status among the Rama and was calculated as:

$$\text{Number of deaths during a year} / \text{Total population at midpoint of the year} * 1,000 \quad (1).$$

IMR is an important measure of health and development of the child population and is expressed as:

$$\text{Number of infant deaths under 1 year} / \text{Midyear total of all births} * 1,000 \quad (2).$$

Age is the most important variable in the analysis of mortality; however, this measure is affected by the composition of the population and therefore is analytically limited (McGehee 2004). In order to estimate which segments of the population die each year, the ASMR for individual age-groups was calculated as:

$$\text{Number of deaths of an age group during a year} / \text{Population} * 1,000 \quad (3),$$

FMR is the estimator of the fetal mortality or pregnancy losses prior the completion of the birth process, and was calculated as:

$$[(\text{Number of fetal deaths}/\text{Number of live births}) + \text{Number of fetal deaths}] \times 1,000 \quad (4),$$

NMR is the number of resident newborns dying at less than 28 days of age divided by the number of resident live births and is expressed as:

$$[\text{Number of newborns (< 28 days)}/1,000] \quad (5),$$

MMR calculates the risk of dying as a result of complicated pregnancy, childbirth, and puerperium (McGehee 2004). MMR is expressed as:

$$[\text{Number of maternal deaths} / \text{population}]/100,000 \quad (6).$$

## **Fertility Rates**

Fertility rates are analytically useful for inter-area and inter-group comparison. A number of measures have been developed in demography such as: age specific fertility rates (ASFR), general fertility rates (GFR), and total fertility rates (TFR). ASFR is a set of 5-year groups often used for comparison with other populations. GFR is defined as the number of births (regardless of the interval of time) in the numerator divided by the female population of 15-49 years of age.

The TFR indicates the average number of children that would be born during their lifetime (Estee 2004).

The study of vital statistics in developing regions such as the southern Caribbean of Nicaragua is problematic because official data are deficient and vary in accuracy and detail (see: Hobcraft et al. 1982; Popoff and Judson 2004). For this reason, William Brass (1975; 1996) and others (Coale and Trussell 1974) have developed methods such as the  $P/F$  ratio for estimating fertility among populations with deficient demographic records. In general, the  $P/F$  ratio of birth histories assumes that fertility ( $F$ ) has been constant in the past; hence, reproductivity can be estimated by means of the number of children ever born to an individual ( $P$ ). The  $P/F$  procedure adjusts the observed level of age-specific fertility rates (ASFR) that represent the true age pattern of fertility in agreement with the level of fertility indicated by the average parity of women (Hobcraft et al. 1982).

Fertility rates from incomplete reproductive data of the Rama Amerindians were approximated by means of the software EASWESPOP v. 2.0 (1992). This software requires basic input information on the children ever born as reported by five-year age groups of women between 10 and 49 years old (before 2008) irrespective of marital status. The program generates an output file with information on the average parities, cumulated fertility,  $P/F$  ratios, and rates on fertility for five-year age groups of women between 15 and 49.

The previous analysis on fertility was based on information obtained from the demographic questionnaire and included information on child delivery, such as the type of attention received by women in labor. This information was useful in estimating changes in pregnancy health care over time.

## Effective Population Size

The effective population size ( $N_e$ ) is the number of reproductive adults in an idealized population ( $N$ ) of constant population size, equal sex ratio, (50:50), and random variation in fertility that has same reproductive parameter as the non-ideal population under study. Due to deviations in these factors, genetic drift can impact the population dynamics of human groups (Relethford 2012). For example, genetic drift can reduce or increase allele diversity faster in small populations than in large groups. The effective population size can be used to approximate the impact of different evolutionary forces in a population and measure the magnitude of genetic drift (Jobling et al. 2004). In this dissertation  $N_e$  was approximated using Wright's (1962) equation:

$$N_e = \frac{4N - 4}{2 + V} \quad (7),$$

where  $N$  is the Rama breeding population size of individuals between 15 and 45 years of age, and  $V$  is the average number of births per reproductive women at the end of their reproductive history.

## Opportunity for Natural Selection

Natural selection can be defined as the differential survival and reproduction of genotypes in a population which leads to microevolutionary changes when certain individuals produce more viable offspring than others and thus make up a larger proportion of the gene pool

of a population (Reddy et al. 1987). Selection is often expressed as a function of fitness or the relative reproductive success of different genotypes and is contingent upon the variation of fertility and mortality in populations (Halberstein 1973). In order to ascertain selective pressures in human populations, Crow (1958; 1966) derived an index that makes apparent the reproductive pattern of a population and measures the proportion by which fitness will increase based on death and birth rates when the heritability of fitness is completed in the reproductive career of a female. The Crow's index for opportunity for natural selection is contingent on sociocultural factors and only measures an upper limit for the potential action of natural selection and cannot be used as an analytical index because it reveals no information on the association between fitness and particular genotypes (Alfonso-Sanchez et al. 2004; Reddy et al. 1987). Despite these limitations Crow's index has been widely used in human populations (Crawford 2001).

Crow's index can be derived using two components, one due to differential fertility and the other due to differential mortality using the following formula:

$$I = I_m + \sigma^2 / P_s, \quad (8)$$

where  $I_m = P_d / P_s$ , and  $I_f = \sigma^2 / \mu^2$ .  $I$  is the index of total selection.  $I_m$  is the index of mortality.  $I_f$  stands for the index of fertility.  $\mu$  is the mean number of live births.  $\sigma^2$  is the variance of live births.  $P_d$  is the proportion of children who died before 15 years of age, and  $P_s$  is the proportion surviving to reproductive age (>15). In this study, Crow's index was applied to 106 reproductive women between 2004 and 2005. All women aged over 49 were included because they had completed their reproductive carriers.

## Population Change

In order to examine general population change over time, the total population of different time periods was compared between the *comarca* of Rama Cay and RAAS. Population change was calculated as:

$$\text{Percent } (P_{t,t+n}) = \left[ \left( \frac{P_{t+n} - P_t}{P_t} \right) \right] * 100 \quad (9)$$

where  $P_{t,t+n}$  equals the population change that took place between two time periods,  $P_{t+n}$  is the population in a later time period, and  $P_t$  is the population in a prior time period.

## Time Series Analysis

Time series analysis was used to examine the trend of mortality patterns over three different populations' aggregates: RAAS, the *comarca* of Rama Cay, and the death records of the Moravian church. Because these aggregates inhabit areas of similar ecologies, they might experience similar epidemiological trends and an expected pattern in time series analysis (Lin and Crawford 1983).

In order to examine if calendar years (explanatory variable) were related to the number of deaths (response variable), a regression analysis using the least square method was performed for three population subdivisions (RAAS, *comarca*, and Rama population). If trends remain invariant with respect to time, they are said to be stationary (sinusoidal) and fitted for time series analysis. If a trend was not stationary, data were transformed by the method of differences (Tabachnick and Fidell 2001) until a constant mean and variance was achieved. This procedure was repeated

until residuals were random and normally distributed. Three measures of accuracy (MAPE, MAD, and MSD) were used for choosing the best fitted model. The smaller the values associated with these measures, the better the fit.

The mean absolute percentage error (MAPE) measures the accuracy of fitted timeline values and expresses the accuracy as a percentage. MAPE was calculated as:

$$\frac{\sum |(Y_t - \bar{Y}_t)|}{n} \times 100, (Y_t \neq 0) \quad (10),$$

where  $Y_t$  equals the actual value,  $\bar{Y}_t$  equals the fitted values, and  $n$  equals the number of observations. MAD stands for mean absolute deviation measures and is a measure of the accuracy of the fitted time series values. This statistic helps to conceptualize the amount of error and is calculated as:

$$\frac{\sum_{t=1}^n |Y_t - \bar{Y}_t|}{n} \quad (11).$$

MSD stands for mean square deviation. Because MSD takes the same  $n$  values in the denominator, this statistic can be use to compare and choose among different models:

$$\frac{\sum_{t=1}^n |Y_t - \bar{Y}_t|^2}{n} \quad (12).$$

Separately, the degree of association between mortality and time (years) for the series ( $X_t$ ,  $X_t$ ) was assessed through cross-correlation:

$$\frac{\sum_{t=1}^{n-k} (x_t - \bar{x})(x_{t+k} - \bar{y})}{S_x S_y} \quad (13),$$

where  $n$  is the number of observations,  $t$  is the row number, and  $k =$  lags or time periods separating data and ranges between +1 to -1. Coefficients are significant when  $> (2\sqrt{n-2})$ .  $\bar{x}$  is the mean of  $x$ , and  $\bar{y}$  the mean of  $y$ . and  $S_x$  and  $S_y$  is equal to:

$$S_y = \sqrt{\sum_{t=1}^n (y_t - \bar{y})^2}, \quad S_x = \sqrt{\sum_{t=1}^n (x - \bar{x})^2} \quad (14).$$

Subsequently, the time series routine from MINITAB (2003) was used to choose the appropriate model (ARIMA) and the type of component that best fit the time series' movement (trend [T], cyclic [C], seasonal [S], or irregular [I]). ARIMA ( $p,d,q$ ) stands for autoregressive ( $p$ ), integrated ( $d$ ), and moving average ( $q$ ). The autoregressive element  $p$  in ARIMA represents the persistent effects of preceding scores (number of autoregressive terms). The integrated element  $q$  represents trends in the data (number of seasonal or non-seasonal differences), and the moving average  $q$ , represents the persistent effect of previous random shocks (the number of forecast errors) (Tabachnick and Fidell 2001). ARIMA fits a Box-Jenkins ARIMA model (Box et al. 1994) to a time series using correlational techniques (differencing, autocorrelation, and partial



correlations, explained above) in order to choose the best model that accounts for the underlying patterns that may not be visible with plotted data.

In addition, parameters, accuracy, and forecasting were examined in order to predict mortality patterns under similar environmental conditions. If the mortality data was not stationary as was stated earlier, it was transformed by differencing, that is, by calculating the differences among pairs of two observations. For example, Lag 1 is between  $Y_t - Y_{t-1}$ . The number of times necessary to make the data stationary determines the value of  $d$  —trend terms—. Differences were examined by the autocorrelation function (ACF) and the partial correlation function (PACF). Autocorrelations are self-correlations of the series with itself, and partial correlations are self-correlations with intermediate autocorrelations (Tabachnick and Fidell 2001). These two functions serve to identify what type of autoregressive or moving average is best fitted.

The graphs obtained from the ACF and PACF functions include lines representing two standard errors to either side from zero. All values that extend over the 95% confidence limits are statistically significant at  $\alpha = 0.05$  and show that the model has not explained all autocorrelation in the data. ACF is defined by the formula:

$$2 \sqrt{\frac{1 + 2 \sum_{k=1}^{i-1} r_k^2}{\sqrt{n}}} \quad (15),$$

where  $n$  = the number of observations in the series and  $r_k$  = the  $k_j$  autocorrelation. For all partial autocorrelations the distance between the lines and zero is  $2/\sqrt{n}$ .

The plot of ACF and PACF assisted in identifying which autoregressive or moving average better fit the model.

### ***SURNAME ANALYSIS BASED ON ISONYMY***

Coalescence based on surname (Isonymy) is an alternative method for inferring genetic structure, marital migration, admixture, and drift in human populations (Koertvelyessy et al. 1988; Lasker 1985; Rodriguez-Larralde et al. 2011). Isonymy studies assume that surnames are of monophyletic origin and transmitted genetically from parents to biological children (Lasker 1991). Additionally, a system based on paternal surname transmission can simulate neutral alleles (Colantonio et al. 2003). Because surnames are inherited paternally among all members of the Rama, the surnames of female participants were included in the sample. The purpose of this analysis is to model all lines of descent as marked by surname inheritance (Lasker 1985). Despite its extended use and application in evolutionary studies (e.g., Colantonio et al. 2003; Rodriguez-Larralde et al. 2011; Salas et al. 2009), isonymy estimates can be unrealistic if the population size is small, subdivided into ethno-social groups, or if a large number of individuals are from extramarital relationships; however, these difficulties can be minimized if the sample size is large (Colantonio et al. 2002). These confounding problems are reduced in this study by including ~42% (n = 592) of all Rama surnames.

In order to evaluate the causes of geographic variation and its effect on population subdivisions in seven Rama subpopulations it is assumed that marital surnames tend to deviate from panmixia due to geographic distance and sociocultural factors. In theory, non-random mating will also have an effect on gene frequencies (Barrai et al. 2002).

## **Genealogical Reconstructions**

Based on demographic information gathered in the field as indicated at the beginning of this chapter, genealogies were reconstructed using the software package GenePro v.2.0.0.2. This program allows for the linking of family-related individuals within and between communities using graphic representations (appendix 4). In order to avoid surname misspellings or duplication of any given sample, the sample was cross checked in Excel. Individuals and their family members who belong to another non-Rama ethnicity were examined further in the genealogies.

Statistical analysis was performed in the programming language R v. 2.13.1 (R 2011) with the package of biodemographic functions, Biodem (Boattini et al. 2012), as well in Excel v.2007 yielding equivalent results.

## **Migration, Kinship Networks, and Mate Choice Behaviors**

Based on information on the place of birth and post marital migration, the percentage of couples born within the Rama territory, or other non-Rama communities, was estimated for all seven Rama subpopulations. In addition, the number of exogamic relationships within Rama communities was obtained from the GTRK (2005-2007) census data.

Another approach for estimating migration and network relationships between Rama communities was done by constructing migration and kinship network matrices. Migration matrices provide information on the relative effect of gene flow and genetic drift, and can be used to test how well genetic variation fits those predictions (Relethford 2012).

A matrix of migration was constructed using the population of origin as row numbers and the population of residence as column numbers. According to Relethford (2012), each element of

the matrix  $m_{ij}$  is the probability that an individual in population  $j$  came from population  $i$ . Once determined, each element of the matrix was divided by corresponding column totals.

A triangular matrix for estimating probabilities of kinship networks between Rama communities was constructed by counting of the number kin related individuals between two villages (rows and columns) and dividing by corresponding column totals.

### ***Neighbor Joining (N-J)***

The neighbor joining (N-J) is a clustering method for displaying distances in a phylogenetic dendrogram (Saitou and Nei 1987). The N-J method attempt to find a tree with the minimal value of  $S$  —shortest overall tree— and uses the least square approach to minimize the sum of branch lengths under the minimum evolution criterion (ME):

$$\min \sum_{1 \leq i < j \leq n} (t_{ij} - d_{ij})^2 \quad (16),$$

where  $t_{ij}$  is the sum of the branch length that connects data ( $i$  and  $j$ ).  $d_{ij}$  is the distance between taxa  $i$  and  $j$  (Felsenstein 2004).

Migration matrix values were transformed into Euclidian distances and were then graphically represented by means of the software NTSYSpc 2.11c (Rohlf 2002).

### **Surname Distribution**

According to Barrai, et al. (1996), surname occurrence greater than 50% indicates surname membership to a specific location. However, this assumption can be problematic because with small sample sizes few last names will score as location-specific. Scale of

specificity is expressed by dividing the absolute number of a specific surname in a community by its total frequency. The scale of surname specificity varies from 1 (more specific) to 0 (no specificity).

In this study, the method of scoring the frequency of last names among Rama communities was used to assert the distribution of “founding” British surnames and surnames of more recent appearance within communities (e.g., Spanish surnames). A Chi-square ( $\chi^2$ ) analysis was performed to test the null hypothesis of the absence of association between surname frequencies and the level of specificity.

### **Surname Variation within Subpopulations**

To determine the degree of isolation within Rama localities (subpopulations) four test statistics were calculated: Unbiased Isonymy ( $I_{ii}$ ), Fisher’s alpha ( $\alpha$ ), Lasker’s coefficient of Isonymy within populations ( $R_i$ ), and the kinship parameter Phi ( $\Phi_{ii}$ ).

Unbiased random isonymy  $I$  (Relethford 1988) approximates the amount of isolation of subpopulations with the formula:

$$I_{ii} = \frac{\sum n_{ik} n_{jk}}{N_i N_j} \quad (17),$$

where  $n_{ik}$  and  $n_{jk}$  are the number of individuals with surname  $k$  in populations  $i$  and  $j$ .  $N_i$  and  $N_j$  are the total number of surnames in populations  $i$  and  $j$ . Summation is over all surnames. High values indicate an elevated degree of isolation and low values an increase of migration and therefore of admixture (Rodríguez-Larralde 1993).

Morton *a-priori* kinship ( $\Phi$ ), described by Relethford (1988), identifies values of kinship within populations and is defined by  $\Phi_{ii}$ :

$$\Phi_{ii} = \frac{I_{ii}}{4} \quad (18),$$

where  $I_{ii}$  is given in equation (17). Fisher's  $\alpha$  (Fisher 1943), is used to estimate surname diversity and infer genetic isolation and is calculated from  $I$ . This statistic is analogous to the effective number of alleles in a genetic system and it is defined by a formula derived by Barraï et al. (1992):

$$\alpha = \frac{1}{I} \quad (19),$$

Large values of  $\alpha$  indicate high migration levels while low values indicate isolation, higher inbreeding, and genetic drift (Bronberg et al. 2009).

From a model proposed by Crow and Mange (1965a; 1982) Lasker's coefficient of relationship by isonymy  $R_i$  was formulated (Lasker 1968; 1969; Lasker and Kaplan 1985), and applied to quantify surname relationships within communities:

$$R_i = \sum \frac{S_i(S_i - 1)}{2_n(n - 1)} \quad (20),$$

where  $S_i$  is the number of each surname and  $n$  is the number of individuals in a population. In order to test the significance between isonymy values, Fox and Lasker (1983) established that two  $R_i$  values significantly differ at  $p < 0.05$  if:

$$\frac{R_{i1} - R_{i2}}{\sqrt{(R_{i1})^2 + (R_{i2})^2}} > \frac{1}{2} \quad (21).$$

### **Surname Variation between Subpopulations**

In order to explore the relationship between seven Rama subpopulations, three test statistics were performed: the Lasker's coefficient of relationship between subpopulations ( $R_{ib}$ ), Isonymy coefficients between populations ( $I_{ij}$ ), and a kinship matrix ( $\Phi_{ij}$ ).

Lasker's coefficient of relationship can be used to evaluate the relationship between populations  $R_{ib}$ . The degree of affinity given by  $R_{ib}$  assumes that individuals with shared surnames are more closely related than those without a shared surname (Colantonio et al. 2003).

$R_{ib}$  is established by the formula:

$$R_{ib} = \left[ \frac{\sum S_{i1} S_{i2}}{2n_1 n_2} \right] \quad (22),$$

where  $S_{i1}$  and  $S_{i2}$  are the numbers of the  $i$ -th surname in the first and second population and  $n_1$  and  $n_2$  indicate the total number of individuals in population 1 and 2 (Sanna et al. 2006).

A matrix of random isonymic values between populations was constructed with the equation:

$$I_{ij} = \frac{\sum n_{ik} n_{jk}}{N_i N_j} \quad (23),$$

where  $n_{ik}$  and  $n_{jk}$  are the number of individuals with surname  $k$  in populations  $i$  and  $j$ .  $N_i$  and  $N_j$  are the total number of surnames in populations  $i$  and  $j$  (Relethford 1988). Unbiased random isonymy values indicate surname affinity between populations.

Values of the *a-priori* kinship matrix between populations ( $\Phi_{ij}$ ) were calculated as:

$$\Phi_{ij} = \frac{I_{ij}}{4} \quad (24),$$

where  $I_{ij}$  are given in equation 23. The term *a priori* refers to kinship relative to a founding population.

### **Population Substructure (subdivision)**

Population subdivision was investigated by using the repeated-pairs (*RP*) approach. This method was originally developed by Crow and Mange (1965a) and later incorporated in surname studies (Lasker and Kaplan 1985). The *RP* method investigates population substructure by assuming the lineage-like behaviors of mate choice. The objective of this method is to estimate the level of homozygosity in a subpopulation on the basis of the repetition of couples with identical surnames. This was done using the following formula:

$$RP = \frac{\sum [s_{ij}(s_{ij} - 1)]}{N(N - 1)} \quad (25),$$



where  $S_{ij}$  is the number of marriages with a husband of the  $i$ th surname and a wife of the  $j$ th surname, and  $N = \sum S_{ij}$ . In order to determine the amount of repetition expected at random, the surnames of wives and husbands were rearranged in random order ( $RP_r$ ) using a model proposed by Chakraborty (1985).  $RP$  scores reveal preferential interlineage marriage patterns (evasion or close inbreeding). If frequencies differ between preferred and non-preferred surnames, any repeated mate preference will elevate  $RP$  values above randomly expected levels; in other words, an excess of  $RP$  on  $RP_r$ , calculated as  $(RP/RP_r)/ RP_r$  will suggest a degree of subdivision internal to a subpopulation.

### **Consanguinity Estimates**

Deviations from panmixia of Rama subpopulations were estimated using the inbreeding coefficient  $F$  (Wright 1921). According to Wright's hierarchical model (Wright 1951), populations are related by a branching process of divergence. Wright's model was expanded by Crow (method B) and includes three components ( $F_t$ ,  $F_r$ , and  $F_n$ ) (Crow 1980; Crow and Mange 1965b). The inbreeding coefficients relative to the total population is expressed by  $F_t$ . The random component  $F_r$  measures the departure from panmixia within a descendant population which is averaged over all subpopulations. This value depends on population size. The smaller the population, the higher the probability that a couple will share surnames (Gonzalez-Martin et al. 2006). Any divergence of a descendant population from a founder population is measured by the nonrandom component  $F_n$ . This value represents the deviation between  $F_t$  and  $F_r$ . Positive values indicate preference between consanguineous marriages, and negative values illustrate the tendency to avoid marriages with partners who share their surname. This relationship is described by the equation:

$$F_t = F_n + (1 - F_n) * F_r \quad (26),$$

with the random component expressed as:

$$F_r = \sum (p_i q_i) / 4 \quad (27),$$

where  $p_i$  is the frequency of surname  $i$  in paternal surnames, and  $q_i$  is the frequency of surname  $i$  in maternal surnames. The nonrandom component is calculated with the formula:

$$F_n = \frac{(P - \sum p_i * q_i)}{4 * (1 - \sum p_i * q_i)} \quad (28),$$

where  $P$  is the frequency of marriages with isonymic surnames.

### **Isolation by Distance**

In order to detect isolation by distance among Rama subpopulations, the linear correlation between Lasker's distance  $D$  (Rodriguez-Larralde et al. 1998), Euclidian distance (Cavalli-Sforza and Edwards 1967), Lasker's coefficient of relationship between communities ( $R_{ib}$ ), and the logarithmic transformation of geographical distance were performed. The significance between matrices was assessed using mantel tests.

Geographical distances between Rama villages were calculated as a straight line in kilometers prior to being log transformed. Euclidian distances were calculated as:

$$(1 - \theta)^{1/2}, \text{ where } \theta = \sum (P_{ik} P_{jk})^{1/2} \quad (29),$$

where  $P_{ij}$  and  $P_{jk}$  is the frequency of surname  $K$  in the  $i$ -th and  $j$ -th Rama community. Lasker's distances  $D$  were calculated with the formula:

$$LD = -\text{Log} \left( \sum P_{ik} P_{jk} \right) \quad (30),$$

where  $P_{ik}$  and  $P_{jk}$  are the frequency of surname  $K$  in the  $i$ th and  $j$ th community. Lasker's  $D$  is a measure of similarity or difference between two populations based on surnames (Rodriguez-Larralde et al. 1998). High Lasker's  $D$  values indicate a lack of surname similarity between two populations. Scapoli, et al. (2006) suggested that this relationship can serve to identify links between cultural and genetic inheritance between homogeneous populations. If populations differ genetically it is likely that they also exhibit differences in cultural behavior.

### ***Mantel Tests***

In order to evaluate the relationship between surnames and geography of the Rama, Mantel tests were performed. Mantel tests (Mantel 1967), which allow an assessment of correlation to be determined between two or more matrices, are expressed by the equation:

$$r_{xy} = \frac{SP(x, y)}{\sqrt{SS(x)SS(y)}} \quad (31),$$

where  $SP$  is the sum of products for the  $x$  and  $y$ , and  $SS$  is the sum of square for each matrix (Smouse et al. 1986). The test of significance uses a permutation procedure from the matrices with the equation:

$$Z_{xy} = x * y = \sum_{i=1}^n \sum_{j=1}^i x_{ij}y_{ij} \quad (32),$$

The permuted  $Z_{xy}$  quantities ( $n=1000$ ) were contrasted with the original  $Z_{xy}$  values to determine the corresponding  $p$ -values (Smouse et al. 1986).

### ***DNA AND BLOOD GROUP POLYMORPHISM ANALYSIS***

DNA extractions, RFLP for haplogroup identification, and PCRs for genetic sequencing were performed by the author in the Laboratory of Biological Anthropology of the University of Kansas. The compilation of blood groups polymorphisms was based on published data.

#### **DNA Extraction**

The Chelex® method for DNA extraction was used with the mouth washes obtained during fieldwork. Precipitated cells in the bottom of each collection tube were divided in half and transferred into two 5.0 mL tubes and then centrifuged for 10,000 RPM for five minutes, the supernatant was discarded and the cell pellet kept in the tubes. 100  $\mu$ L of 10% Chelex® solution was added to each sample. The suspension was placed in a water bath for ten minutes at 100 °C. The boiling process denatures and releases the DNA, destroying proteins and disrupting cell membranes. Five minutes of centrifugation at 10,000 rpm separated the Chelex® resin mixed with protein residue from other cell debris in the bottom of the tube, and from an overflow that

contains the DNA. The supernatant solution was transferred to a 0.5mL tube. In some cases the last step was repeated twice to ensure the supernatant was not mixed with contaminants or residues that may cause PCR inhibition.

DNA from buccal swabs was extracted using the Evogen one® method (provided by Evogen Laboratories, Kansas City MO). Buccal swabs were centrifuged for four minutes at 10,000 rpm and then 50 µL of Evogen one® product were added to each tube. Tubes then were heated at 95 °C for two minutes after being gently vortexed. The supernatants, that contained the DNA, were transferred into of 5.0 mL collection tubes.

### **mtDNA HVS-I Sequencing**

The PCR method was used to replicate a segment of ~400 bp of the HVS-I mtDNA for haplotype evaluation and comparison purposes between the Rama and other populations. Also, specific regions and mutations for RFLP analysis were identified by means of the PCR method.

PCR for mtDNA sequencing and RFLPs for haplogroup identification followed the standard protocol: 5.0 µL of 5x Buffer (Promega, WI), 4.0 µL MgCl<sub>2</sub> (25 mM), 0.5 µL of deoxynucleotide mix (dNTP), 0.2 µL Go TAG Polymerase (Promega, WI), 10.3 µL ddH<sub>2</sub>O, 1 µL forward primer (10 pmole/ µL), 1 µL reverse primer (10 pmole/µL), and 2.0 µL of DNA dilution. The total reaction volume was 25 µL for each sample analyzed. Reagents were purchased from Promega (Madison, WI) with the exception of the oligonucleotide primers synthesized at DNA Technologies (IDT, Coralville, IA). Primers, annealing temperatures, restriction enzymes, corresponding mtDNA haplogroups, and the studied HVR-I segment are shown in table 8.

PCR reactions were run on a Perking Elmer 2400 or Applied Biosystems 9600 following these cycle conditions: one minute denaturation at 95 °C, annealing for 30 seconds at the lower

melting temperature for each primer (see table 8), and extension at 72 °C for 30 seconds. These steps were repeated for 40 cycles.

Table 8. Haplogroup and HVS-I associated sequences, primers, and annealing temperatures

Haplogroup* and HVS-I region	Restriction site	Primer Pair	DNA Sequence (5' → 3')	Annealing temp. ( °C)
<b>HVS-I region</b>	-	15879 For 16459 Rev	AATGGGCCTGTCCTTGTAG GCTACCCCAAGTGTATGG	55
<b>A2*</b>	+ <i>Hae</i> III 663	535 For 725 Rev	CCCATACCCCGAACCAACC GGTGAACYCACTGGAAGGGG	57
<b>B2*</b>	+ <i>Hae</i> III 8250	8149 For 8366 Rev	ACCGGGGGTATACTAACGGT TTTCACTGTAAAGAGGGTTGTTGG	53
<b>C1*</b>	- <i>Hinc</i> II 13259 and + <i>Alu</i> I 13262	13172 For 13383 Rev	GCTTAGGCCCTATCACCA GTTGTGGATGATGGACCC	51
<b>D1*</b>	- <i>Alu</i> I 5176	5151 For 5481 Rev	CTACTACTATCTTCGCACCTG GTAGGAGTAGCGTGGTAAG	53

Amplification of the HVS-I segment was verified in an agarose gel (1.5%) with ethidium bromide, using electrophoresis at ~97 volts for one hour and then visualized in UV light. PCR products were then purified using a QIAquick kit (Qiagen Valencia, CA) according with manufacturer's instruction. A 5:1 ratio of Buffer PB was added to the PCR product in order to bind the DNA; this solution was then placed in a spin column and centrifuged at 10,000 rpm for one minute. Each sample was washed with 750 µL of Buffer PE and centrifuged at 10,000 rpm for one minute. The column was transferred to a new 1.5 mL tube and 30 µL of ddH<sub>2</sub>O was added and allowed to stand for one minute. The solution in the 1.5 mL tube was centrifuged for one minute in order to release purified DNA samples from the column and collect them in the

bottom of the tube. The DNA templates were sequenced using Big Dye Sequencing kits on an ABI 3130 Sequencer (Applied Biosystems, Foster City, CA) at the University of Kansas Sequencing Laboratory by Dr. Michael Grose.

mtDNA sequencing chromatograms resulting from the previous analysis were edited using BioEdit (Hall 1999) and compared to the human Cambridge Reference Sequence (CRS) (Anderson et al. 1981). Variations in nucleotides deviating from the CRS were recorded as DNA sequence variants.

### **RFLP and Haplogroup Testing**

PCR products of amplified DNA were digested with restriction endonucleases that cleaved specific nucleotide sequences (see table 8 for specific primers and sequences). Four (A2, B2, C1, and D1) Native American haplogroups were characterized in the Rama's mitochondrial DNA sample in hierarchical fashion. The protocol for the restriction digest method included: 2.0  $\mu$ L of 10X RFLP buffer (New England Biolabs, Beverly, MA), 1.0  $\mu$ L of 100X bovine serum albumin (BSA), 0.5  $\mu$ L of restriction enzyme (New England Biolabs, Beverly, MA), 7.5  $\mu$ L of PCR product DNA 9.0  $\mu$ L of ddH<sub>2</sub>O. This resulted in a reaction volume of 20  $\mu$ L per sample. RFLP samples were digested for sixteen hours at 37°C using the appropriate restriction enzyme. The reaction was stopped by the addition of 5  $\mu$ L of 3X loading dye to each sample. Digested fragments were visualized on a 3% 3:1 SeaKeme gel (ISC BioExpress, Kaysville, UT) and cooled at 45 °C and stained with ethidium bromide at 97 volts for two hours. A total of 5  $\mu$ L of PCR product and 5  $\mu$ L of 6x loading dye (Promega, WI) were added to each gel well and checked against 50 bp DNA ladder (Promega, WI). A positive sample of a known haplogroup and

a negative control (ddH<sub>2</sub>O) also were added to the wells. The digested products were visualized under UV light.

Because previous studies indicate that the haplogroup A2 and B2 were the most frequent among the Rama (Melton et al. 2013; Melton 2008), in this research 190 samples were tested first for sites diagnostic for these haplogroups. Those samples that did not score as A2 and B2 were tested for haplogroups D1 and C1. If an individual not belong to any of four major Native American haplogroups, they were examined for African (L) based on maternal genealogical information. In addition to this analysis, individuals were crosschecked with their respective HVS-I sequence and haplogroup assignation based on PhyloTree.org nomenclature (van Oven 2010). Haplogroup A2 is recognized through the presence of a *Hae*III cut site at nucleotide (nt) site 663, and B2 by the presence of *Hae*III cut site at nt 8250. C1 by the presence of *Alu*I site at nt 13262 and the absence of *Hinc*II recognition site at nt 13259. D1 is identified by the *Alu*I cut site at the nucleotide site 5173.

### **Classical Genetic Polymorphisms**

As an approximation of autosomal markers, classical polymorphisms used 22 alleles of seven systems (ABO, MNSs,P, Kidd, Diego, Rhesus, and Duffy) of 24 populations from Mesoamerica, Central America, and South America from published data: Matson and Swanson (1963a; 1963b; 1964a; 1964b; 1965a; 1965b), Matson et al. (1966), Layrisse et al.(1963), and Barrantes et al. (1982).



## ***GENETIC ANALYTIC PROCEDURES***

### **Intrapopulation Variation**

Intrapopulation genetic variation refers to the internal subdivision of populations due to geographic, linguistic, and other cultural factors. Subdivisions can include language families, tribes, religious castes, and other social units (Rubicz et al. 2007). This study used the test statistics detailed below to compare, on one hand, Rama subpopulations as units of subdivision, and on the other hand, populations belonging to different linguistic affiliations from the Caribbean, Central, Meso, and South America.

### ***Genetic Diversity***

The amount of haplotype diversity was estimated by using Nei's gene diversity  $H$  (Nei 1987).  $H$  estimates the probability that two alleles drawn at random from the population will be different from each other. This is also referred as a measure of heterozygosity and was calculated for mtDNA HVS-I with the formula:

$$H = \frac{n}{n-1} \left(1 - \sum_{i=1}^k p_i^2\right) \quad (33),$$

where  $n$  is the number of samples,  $k$  is the number of haplotypes in the sample and  $p_i$  is the frequency of haplotype  $i$  in the sample. The nucleotide diversity  $\pi$  (Nei 1987) is analogous to Nei's gene diversity and it describes the probability that two copies of the same nucleotide drawn at random from a set of sequences will be different from one another. The estimator for mtDNA HVS-I sequences is:

$$\pi = \sum_{ij}^a X_i X_j d_{ij} \quad (34),$$

where  $q$  is the total numbers of alleles,  $X_i$  is the frequency of the  $i$ -th allele in the population, and  $d_{ij}$  is the number of nucleotide differences between alleles  $i$  and  $j$  at a given site.

A population can reach a level of equilibrium under the neutral evolution model. Equilibrium is achieved when the generation of new alleles in the gene pool is canceled by its elimination by drift (mutation drift equilibrium), therefore it is possible to approximate the expected level of diversity by the parameter  $\theta$  —theta— in terms of the mutation rate ( $\mu$  per site per generation) and drift (Jobling et al. 2004). Because drift is inverse to the effective population size  $N_e$  is used in the following equation:

$$\theta = 2N\mu \quad (35).$$

The neutral evolution theory states that genetic variation is better explained by stochastic processes and not by selective forces. According to this theory, most variation does not affect fitness, and polymorphisms will undergo fixation or be eliminated by genetic drift. This process will impact  $N_e$ . Also, neutral evolution theory holds that the rate of evolution is driven by the pace of mutation which is the foundation of the molecular clock theory for timing evolutionary processes (Jobling et al. 2004; Kimura 1968a; Kimura 1968b).

### ***Tests of Selective Neutrality***

mtDNA was used to conduct two neutrality tests: Tajima's  $D$  (Tajima 1989) and Fu's  $F_s$  (Fu 1997) were used to distinguish selection, and the expansion or contraction of populations.

Tajima's  $D$  is based on the infinite-sites model without recombination and assumes that the population is in equilibrium and the sequences are a random sample. The infinite-sites model is the mathematical representation that states that the number of bases on each genome goes to infinity (Ma et al. 2008). Tajima's  $D$  compares two estimators of the population mutation parameter  $\theta$ :

$$D = \frac{\theta_{\pi} - \theta_S}{\sqrt{\text{Var}(\theta_{\pi} - \theta_S)}} \quad (36),$$

where  $\theta_{\pi}$  represents the mean number of pairwise differences between sequences  $\pi$  (defined in equation 35), and  $\theta_S$  the number of nucleotide variant sites or segregation sites. Population expansion is expressed by negative scores due to larger  $\theta_S$  relative to  $\theta_{\pi}$  values whereas bottlenecks in a population are expressed by positive or statistically non significant negative scores (Tajima 1989).

The Fu's  $F_s$  (Fu 1997) uses information from the haplotype distribution and it is commonly used for estimating population expansions. This statistic is also based on the infinite-sites model and is defined in the equation:

$$F_s = \ln\left(\frac{S}{1-S}\right) \quad (37),$$

where  $S$  equals the probability of observing a random neutral sample will be greater or equal to the observed values  $K$  ( $S = \text{PR } K \geq K_{\text{obs}} | \theta = \theta_{\pi}$ ).  $K$  is equal to the number of alleles similar to or less than the observed value  $\theta_{\pi}$ , and  $F_s$  is the logit of  $S$ . Fu's  $F_s$  tests for population expansion

and measures the number of recent mutations. Large negative values indicate an excess of mutations under the neutral mutation theory, suggesting either selection or expansion. On the contrary, a positive value is indicative of genetic drift (Rubicz et al. 2007). Tajima's  $D$  and Fu's  $F_s$  were calculated for mitochondrial DNA sequences with the program Arlequin 3.5.1.2 (Schneider et al. 2000).

### ***Mismatch Distribution***

Mismatch distribution counts the number of differences at any pair of sequences (pairwise differences). For visualization, such differences are usually displayed in a histogram that shows the amount of genetic variation within a population. The shape of the distribution is also informative, a unimodal shape indicates population expansion and a period of rapid population growth from a single haplotype, whereas a multimodal distribution —ragged— indicates constant population size over a long time period (Rogers and Harpending 1992). In order to distinguish between these distributions a raggedness  $r$  statistic sums the square difference between neighbor peaks:

$$r = \sum_{i=1}^{d+1} (x_i - x_{i-1})^2 \quad (38),$$

where  $d$  is the greatest number of differences between alleles, and  $x_i$  is the relative frequency of  $i$  pairwise differences.

### ***Analysis of Molecular Variance (AMOVA)***

AMOVA is analogous to the nested analysis of variance (ANOVA) and is derived from a matrix of square distances among all pairs of haplotypes. AMOVA estimates  $\Phi$ -statistics that are analogous to the  $F$ -statistics by correlating haplotypic diversity at different hierarchical levels of population subdivision (Excoffier et al. 1992). The total sum of square deviations (SSD) is given by the formula:

$$SSD_{(total)} = \frac{1}{2N} \sum_{j=1}^N \sum_{k=1}^N \delta_{jk}^2 \quad (39),$$

where the  $N$  equals the number of haplotypes,  $\delta_{jk}^2$  indicates the Euclidian distance between haplotypes  $j$  and  $k$ . Three statistics ( $\Phi_{st}$ ,  $\Phi_{sc}$ , and  $\Phi_{ct}$ ) summarize the amount of variation at different hierarchical partitions,  $\Phi_{ct}$  indicates the variation within groups relative to the total (among groups),  $\Phi_{sc}$  indicates the variation present in subpopulations between groups (among communities), and  $\Phi_{st}$  measures the variation of the subpopulations in relation to the total (within groups within communities)(Rubicz et al. 2007).

This method was calculated among the Rama communities in order to investigate the presence of substructure within the total sample using mtDNA sequences, as well as among populations belonging to different geographic, linguistic, or cultural areas.

### ***Monmonier's Algorithm and Interpolated Genetic Landscapes***

For detecting patterns of genetic discontinuity, the Monmonier's algorithm (Monmonier 1973), and the interpolated genetic landscape (Miller 2005) were applied.

The Monmonier's algorithm is a phylogeographic procedure that detects barriers of gene flow by identifying distances along a network of interconnected points (Dupanloup et al. 2002; Manni et al. 2004; Miller 2005). The algorithm located edges or barriers associated with rates of change in a given distance measure, in this case, the nucleotide differences between individuals. Then, the algorithm is applied to the generated network of interconnected points using the Delaunay triangulation based on the geographical positions of the studied populations —points— (Brouns et al. 2003). The Delaunay triangulation are encircled by Voronoï tessellations, or polygonal boundaries that provide a visual representation of the natural features (Manni and Guerard 2004; Manni et al. 2004)

The software Barrier v.2.2 (Manni and Guerard 2004) generates the representation of the interpolated landscapes by localizing barriers and their interconnections with points and genetic distances using the Delaunay triangulation method explained above. The network is then plotted in a three dimensional geographical grid with x, y, and z axes.

The z axis in the three dimensional grid represents the genetic differences between populations, whereas the x/y represents geographic coordinates. Valleys below the x/y plane represent genetic similarities, and the peaks above the x/y plane indicate genetic differences (Miller 2005). Pairwise genetic distances  $Z$  are calculated with the formula:

$$Z = \frac{\sum_{i=1}^n w_i \times z_i}{\sum_{i=1}^n w_i} \quad (40)$$

where  $w_i$  is a weighting function assigned to each  $z_i$  that is inversely proportional to geographic distances between the  $x$  and  $y$  coordinates and corresponding distances ( $x_i$  and  $y_i$ ).  $w_i$  is mathematically expressed in the equation:

$$w_i = \frac{\left\{ \left[ (X_1 - x)^2 + (Y_i - y)^2 \right] \right\}^{-a/2}}{1} \quad (41),$$

where  $a$  is the weight value of distance and varies between 1 and 0.

### **Interpopulation Variation**

Interpopulation genetic analysis provides information about the stochastic processes that impacted population structure and phylogeny, and provide information about the evolutionary forces acting on them, for example, effects of geographic or linguistic isolation. (Rubicz et al. 2007). In this study, population comparisons were established based on genetic distances and displayed in graphical representations. Methods for interpopulation variation analysis are explained in the following sections.

### ***Genetic Distance Measures***

Various genetic distance measures have been developed in order to estimate the relationship between populations and underlying evolutionary mechanisms, depending on the molecular system under study. For example, protein polymorphisms in classical markers have few alleles, experience a low mutation rate, and evolve according the infinite allele model (Tajima 1996). Other genetic distances have been developed to measure genetic distances in

microsatellite loci due to their mutational dynamics, incorporating the stepwise mutational model that takes into account information on the molecular distances between alleles. The objective in any genetic distance measure is to determine if the distance between populations is significantly different from zero (Jobling et al. 2004).

For classical genetic markers the Nei's  $D$  was used and is represented in the following equation:

$$D = -\ln \left( \frac{\sum x_i y_i}{\sum x_i^2 (y_i^2)^{1/2}} \right) \quad (42),$$

where  $\sum x_i y_i$  is the probability of drawing two identical alleles from the two different populations divided by the probability of drawing identical alleles from the same population  $\sum x_i^2 (y_i^2)^{1/2}$ . For the mtDNA sequence data Tamura and Nei (1993) distances were corrected for mutation rate heterogeneity between transitional and transversional substitutions using the  $\gamma$ -value of 0.26 in order to give a less biased estimate of the genetic diversity of the mtDNA HVS-I (Meyer et al. 1999).

### ***Heterozygosity and Distance from Centroid ( $r_{ii}$ )***

In order to study the effects of migration and genetic drift, the heterozygosity (gene variability) and distance from the centroid ( $r_{ii}$ ) method (Harpending and Jenkins 1973; Harpending and Rogers 1984) between populations was applied. This method uses the equation:



$$r_{ii} = \frac{(p_i - \bar{p})^2}{\bar{p}(1 - \bar{p})} \quad (43),$$

where  $p$  is the frequency of a particular allele in a  $i$ th population and  $\bar{p}$  is the weighted mean frequency for all populations. Deviations between heterozygosity and  $r_{ii}$  relationship will indicate two forces of evolution acting on populations (gene flow or genetic drift). Due to the linear relationship between  $r_{ii}$  and heterozygosity, populations that appear above the regression line are considered to be under the effect of genetic flow and those below the regression line are under the effect of drift on an x/y axis.

The calculation of the mean heterozygosity and  $r_{ii}$  values were done in ANTANA (Harpending and Rogers 1984) and regressed in the statistical package MINITAB v.14 (MINITAB 2003). This method was applied to classical genetic markers.

### ***R-matrix***

*R*-matrix is a PCA method that uses a variance-covariance matrix (Harpending and Jenkins 1973) of gene frequencies for examining population structure and population history. *R*-matrix is calculated using the sample coefficient of kinship  $r_{ij}$ :

$$r_{ij} = 1/K \sum_{i=1}^k \frac{(p_i - \bar{p})^2}{\bar{p}(1 - \bar{p})} \quad (44)$$

where  $\bar{p}$  is the weighted mean frequency of the allele under analysis.  $p_i$  and  $p_j$  are the frequencies of the allele  $p$  in populations  $i$  and  $j$  and  $K$  is the number of subdivisions. The division of the

product of the difference of the gene frequencies from the mean by mean times its complement normalizes the data. The advantage of this method is that uses the overall covariance matrix ( $R$ -matrix) based on the allele distances matrices that are weighted by the effective population size and not by their sample size, and it is also independent of the mean (Harpending and Jenkins 1973). Then the  $R$ -matrix is plotted in a PCA (Principal Components Analysis). The PCA method reduces the dimensionality of the data and retains as much information as possible (Manly 2005).  $R$ -matrix analysis was used to establish the genetic relationships between comparative populations of Mesoamerica, and Central and South America using classical genetic markers and HVS-I mtDNA sequence data.

### ***Multidimensional Scaling (MDS)***

Similar to the PCA method, the MDS method constructs diagrams based on genetic distances to show the relationships between objects, in this case, populations. This method starts assigning  $n$  objects to a  $t$  dimensional space, second, a matrix of distances between  $n$  objects are calculated for the previous configuration  $\delta_{ij}$  (rows and columns). Let  $d_{ij}$  be the distance between object  $i$  to object  $j$ , then a regression of  $d_{ij}$  on  $\delta_{ij}$  is computed. A monotonic function ( $d_{ij}^f$ ) was chosen because the configuration distances  $d$  and the data distances  $\delta_{ij}$  are non metric (Manly 2005). A goodness of fit is then calculated using the configuration distances and the disparities are measured using Krustal's stress formula:

$$STRESS\ 1 = \left\{ \frac{\sum (d_{ij} - d_{ij}^f)^2}{\sum d_{ij}^f{}^2} \right\}^{1/2} \quad (45).$$

The stress value is considered a goodness of fit value. The lower the stress value in a range from 0 to 1 is synonymous of a good fit for the values and it also indicates that they are non-random, or not without structure (Manly 2005; Sturrock and Rocha 2000).

MDS was constructed for mtDNA sequence data and classical genetic markers using the statistic package NTSYS v. 2.1 (Rohlf 2002).

### ***Median Joining Networks (M-J)***

Some biological processes are better represented in networks or reticulations than in phylogenetic trees because they reunite and merge two previously split haplotypes, or separate groups from an ancient common ancestor. Network phylogenies contain the information of several trees in a graphic representation. One of the advantages of this method is that it resolves conflict errors caused by homoplasy resulting from parallel mutations or reversions and link splitting phylogenies in a set of genetic connections. When recombination is absent, such as in mtDNA data, this approach is advantageous (Bandelt et al. 1999; Jobling et al. 2004).

M-J networks were used to determine genetic relationships among haplotypes within the studied populations using mtDNA HVS-I genetic sequences and for three Native American haplogroups (A, B, C). Minimal spanning networks were constructed using the software NETWORK v.4.6.1.0 (Fluxus-Technology 2011).

### **Chronometric Techniques**

Chronometric techniques depend on the theory of the molecular clock where genetic variation consisting of mutation accumulates at predictable rate. The measurement of this rate can be approximated by the observation of the mutations occurring in rapid mutation markers and can be calibrated in conjunction with radiometric ( $C^{14}$ ) methods of relative dating from the

archaeological or paleontological records. This method assumes no effect of natural selection on the loci under investigation. The number of mutations can be counted and related to the time of the most recent common ancestor (MRCA) (Jobling et al. 2004; Rubicz et al. 2007).

After constructing phylogenies using the M-J networks of intra-allelic diversity, the mutational changes can be counted from the network by means of the statistic  $\rho$  —rho—, which represents the average number of mutational changes between the root haplotype and individuals in the sample. This statistic is related with time using the equation:

$$\rho = \mu * t \quad (46),$$

where  $\mu$  is the mutation rate and  $t$  is time in generations.  $\rho$  was calculated with the software NETWORKS v.4.6.1.0 (Fluxus-Technology 2011).

Another method to approximate time of expansion uses the pairwise differences between nucleotide sequences by an increasing rate of  $2\mu$  for each generation during population growth, then  $N$  —population size— is estimated for a sample prior to population expansion. To estimate initial timing of population growth the following equation was used:

$$\tau = 2\mu t \quad (47)$$

where  $\tau$  is time generations and  $\mu$  is the mutation rate. Taking the parameters  $\theta_0$  before and  $\theta_1$  after the expansion and fitting the  $\tau$  into the least square method to the observed mismatch distribution allows for the estimation of expansion in mutation units over time (Rogers and Harpending 1992).

The last method used for approximating the time divergence between pair populations was the Reynolds et al. (1983a) model for mtDNA sequences. This model uses the pairwise  $F_{st}$  as short-term distances and is described with the formula:

$$F_{st} \approx 1 - \left(1 - \frac{1}{N}\right)^t \approx 1 - e^{-t/N} \quad (48),$$

where  $N$  is the haploid population size having divergent  $t$  generations ago. The divergence is calculated with the genetic distance equation:  $D = -\text{Log}(1 - F_{st})$  which is approximately proportional to  $t/N$ . Dates were approximated using the program Arlequin v.3.1 (Excoffier and Lischer 2011).

## **SUMMARY**

This chapter provides the methodological component of this project and information on the fieldwork and sample collection carried out among the Rama Amerindians from Nicaragua (2007/2009). Separate sections include first, laboratory methods for DNA extraction and analysis; second, the methods for ascertaining the demographic profile of the Rama including statistics on mortality, fertility, leading causes of disease, and size and composition of the population; third, population structure analysis based on genealogical reconstructions and surname isonymy. A number of statistical tests were applied in this segment of the study in order to approximate migration patterns, mate choice behaviors, admixture, and the geographical variation between Rama subpopulations, as well as four, intra- and inter-population comparisons based on mtDNA and classical genetic polymorphisms. Population structure was assessed at two different population levels: first, by comparing the genetic variation between Rama

subpopulations based on mtDNA sequences and haplogroup and haplotype diversity; and second, comparing the Rama with other Caribbean, Mesoamerican, Central American, and South American populations. These analyses include test statistics for exploring the forces of evolution operating on the Rama, relationships and philogeographic differences with other Amerindian populations based on genetic sequences and diversity estimates. In addition, graphical representations based on multivariate statistics permitted the visualization and interpretation of population and subpopulation relationships.

## V- RESULTS

This chapter presents the results of three analyses and associated methods. The first analysis is the demographic profile of the Rama and includes the population's age and sex structure, an evaluation of health and basic needs, as well as rates and patterns of birth and mortality over time. The second analysis based on paternal surnames but biparentally transmitted in order to approximate migratory patterns and population structure using and for comparing with the information provided by maternal mtDNA analysis. The final analysis compares the genetic structure of the Rama to other indigenous populations in the Americas by means of mtDNA and classical genetic polymorphisms.

### *DEMOGRAPHIC PROFILE*

#### **Age and Sex Structure**

According to the GTR-K (2007) survey there are 1413 Rama Amerindians inhabiting the communities of Rama Cay, Sumu Kat, Zompopera, Wiring Cay, Punta Aguila, and Indian River/Greytown, with 55.5% of the total population residing in Rama Cay. This figure includes individuals living in the city of Bluefields. The second largest community is Greytown, at 14.4% of the population, followed by Punta Aguila, which accounts for almost 10% of the population. The remaining 20% is distributed between Zompopera, Wiring Cay, and Sumu Kat (Table 9). The total population reported in the GTR-K survey (GTR-K 2007) is close to the total figure of 1430 individuals obtained in the course of this research (years 2007 and 2009). However, an important segment of the Rama inhabits areas outside the Rama territory in other provinces of Nicaragua and Costa Rica (A.S.P.I.A.L 2012; GTR-K 2007). These individuals were not

included in the demographic statistics of this dissertation. Males predominate in four communities: Rama Cay, Sumu Kat, Wiring Cay and Indian River/Graytown, while females are more numerous at Punta Aguila and Zompopera. The difference in male and female sex ratios may result from relocation between communities and not from a sex imbalance in birth rates.

Table 9. Population census according with the GTR-K (2005-2007).

Community	Men	Women	Ratio M:F	Total	%
Rama Cay	396	389	102	785	55.5
Sumu Kat	59	49	120	108	7.6
Zompopera	44	62	71	106	7.5
Wiring Cay	37	34	108	71	5.1
Punta Aguila	68	72	94	140	9.9
Indian River/Greytown	107	96	112	203	14.4
Total	702	711	-	1,413	100

Source: Rama population census 2005-2007 (GTR-K 2007).

Because the segregation of individuals by sex and age was not available for reconstructing the demographic pyramid, those variables were extrapolated in order to approximate the hypothetical shape of the demographic pyramid of the Rama based on tables 9, 13, and 17. According to these sources, male to female ratio is slightly higher for females (~50.3) and the proportion of male to female child mortality is close to 50:50. The census by the regional government (GTR-K 2007) indicates that the Rama and Creole populations are predominantly young, with 42% of the population under 15. The older segment of the population, between 46-89 years, represents 35% of the total. Figure 13 shows the age-group distribution of these two populations on the Southern Caribbean coast of Nicaragua. Based on this information it can be said that the population pyramid for the Rama in southern Nicaragua is expanding and has a narrow base. A drop in birthrates has led to fewer children under 4 years



old, and mortality is high for individuals between 15 and 45 years of age. The high percentage of individuals between 46 and 89 years is striking and may correspond to immigration, the migration out of the segment of the population between 15 and 45, or lower survivorship rates among individuals between ages 15 and 45. The latter scenario is more plausible according to the specific and crude mortality and fertility rates reported in following sections.

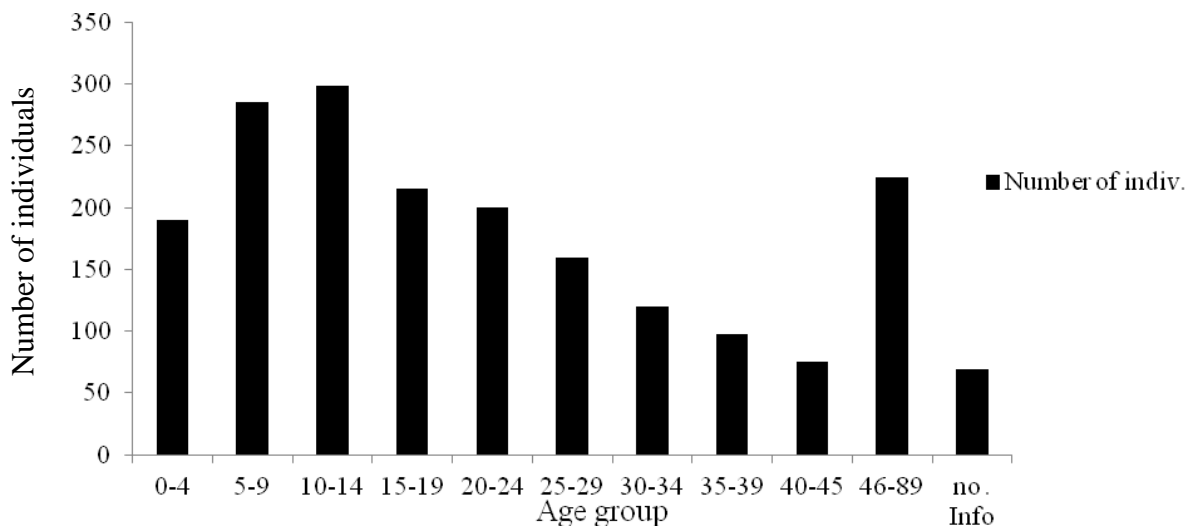

Figure 13. Age-group distribution of Rama and Creole populations in the Southern Caribbean coast of Nicaragua. Source GTR-K (2007).

The pyramid in figure 14 was constructed based on a sample size of 4185 individuals claiming Rama ethnicity on the 2005 Nicaraguan national census (A.S.P.I.A.L 2012). In addition to individuals from the RAAS, the census included those from other *departamentos* or administrative divisions in Nicaragua. In contrast with the previous age-group distribution, this pyramid is also expanding but presents two important differences, first, the broader base indicates high survivorship of children under 4 years of age and the segment of the population

older than 40 years is small. The difference in demographic structures seen in these two graphs can be explained by differential access to medical services and the recent immigration and enculturation of non-Rama immigrants (see following section). Because both instruments had a different definition of ethnicity they produced contrasting results.

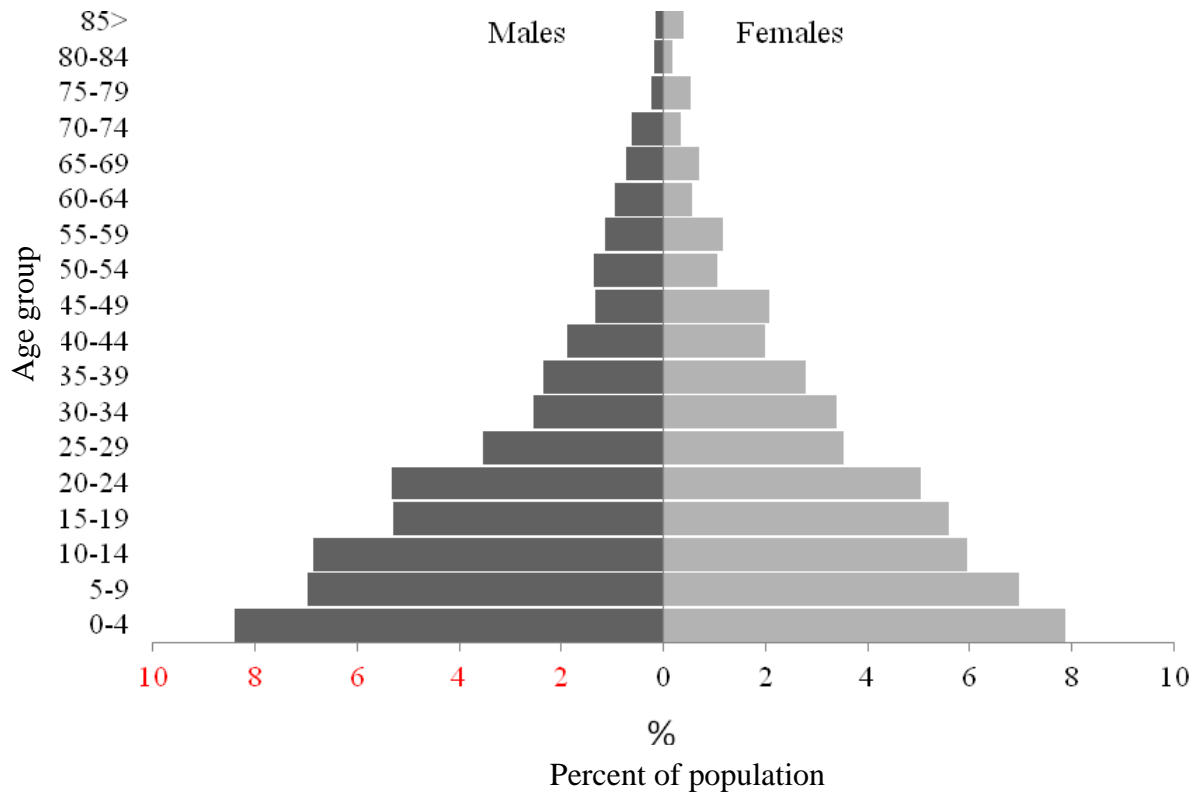

Figure 14. Rama population pyramid for 2005 based on official governmental data (A.S.P.I.A.L 2012).

### Population Change

From 2002 to 2007, the population density of the southern autonomous region of Nicaragua (RAAS) decreased from 17.5 % to 2.7%, while the population at the *comarca* of Rama Cay increased from 5.1% in 2006 to 15% (Table 10). Population change at the *comarca* of

Rama Cay may have resulted from the combination of high birth rates (see section on population growth) and immigration from other areas.

Table 10. Population change for RAAS and the *comarca* Rama Cay between 2002 and 2007.

Year	% Change	
	RAAS	Rama Cay (comarca)
2007	2.7	15
2006	2.7	5.1
2005	-2.5	-10.4
2004	4.7	9.7
2003	0	-2.2
2002	17.5	-3.9

### **Total Fertility and Reproductive Health**

P/F procedure combines the most accurate information available in order to obtain estimates of age specific fertility for the recent past. The P/F ratio method was used in this dissertation for deriving estimates of fertility based on age-specific fertility rates (*F*) among Rama women from 15 until 49 years of age and their children ever born (*P*). It is likely that older women omitted some children, for this reason, the reported number of children in women in their twenties and thirties is more reliable; however, derived fertility rates were reported from all women until the end their childbearing period. Table 11 demonstrates that fertility is higher in women between 15 and 19 years of age compared with older women. The average number of children ever born per woman at the age group 45-49 is 7.8 and represents 25% of the total, while the cumulative fertility rate is 6.2 at the end of the childbearing period. The total fertility rate for Rama women less than 30 years old was 4.5. The estimated TFR of the Rama women is

higher compared to the TFR of 3.9 in the southern Caribbean region of Nicaragua in 2005 (INIDE 2008d), but is lower compared to the estimated TFR for the Miskito Amerindians (8.05) and the Sumo (10.2) of Nicaragua in 1995. Nevertheless, the TFR of the Rama is similar to the Bribri (6.75) and Boruca (6.37) from Costa Rica according to the 2000 census (Perez-Brignoli 2005).

Table 11. General and specific fertility rates computed before 2008 and based on the *P/F* ratio method.

Age group	Fertility Rate (ASFR)	Adjusted Fertility Rate (K=0.131)	Estimated numbers of births	Average parity/woman	Period fertility rate	<i>P/F</i> ratio
15-19	5.143	0.763	2	1.500	5.0000	0.1185
20-24	0.254	0.037	1	1.429	0.3571	0.0544
25-29	0.510	0.075	1	2.091	0.5455	0.0721
30-34	0.075	0.011	0	4.611	0.0556	0.1555
35-39	0.209	0.031	1	4.941	0.2353	0.1613
40-44	0.000	0.000	0	6.909	0.0000	0.2231
45-49	0.000	0.000	0	7.857	0.0000	0.2538
<b>Total</b>	<b>6.193</b>	0.919	4			
Total Fertility: 30.97 4.59						
General Fertility Rate: 0.0452						

Appropriate health care services are important because they enable women to go safely through pregnancy and childbirth and have the best chance of having healthy infants. Based on the information on assisted birth records from the Rama Cay clinic (Table 12), between 1997 and 2002 midwives provided more care to childbearing women during labor and birth (~ 60%) in the local clinic or in patient houses than nurses or doctors in the local clinic or in the hospital of Bluefields (~ 40%). From 2003 until 2008, nurses and physicians from the local clinic or the hospital in Bluefields attended around 45% of pregnant women, but the collaboration of nurses

and/or midwives was also important in the clinic of Rama Cay (~ 40%). However, a decline of midwife-assisted home births was observed in the last period of 2003 and 2008 (Fig.15). Finally, child mortality was reduced from 9 children in the period 1997-2002 to 2 children between 2003 and 2008, a period in which the collaboration of midwives and nurses increased professional childbirth care (Table 12).

Table 12. Maternal health, children birth and mortality (2007-2008).

Assisted by:	Midwife	Nurse or Physician	Midwife and/or Nurse	Other	Number of death children
Place of attention	Clinic or House	Hospital or Clinic	Clinic	Other place	
1997-1999	62	20	0	3	5
2000-2002	60	18	0	-	4
2003-2005	11	17	32	-	1
2006-2008	14	21	10	-	1
Total (n=280)	147	76	42	3	12

Data from Rama Cay clinic 2009.

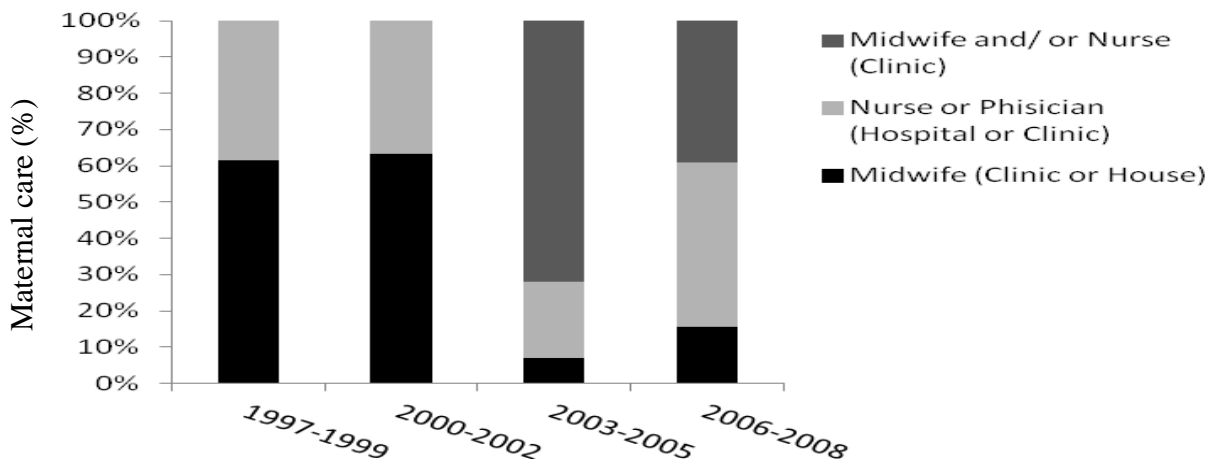

Figure 15. Percentage of maternal care at Rama Cay.

Among the Rama, the midwife's role in delivering children is still an important practice, although in recent years midwives and nurses have collaborated in the delivery process in the clinic at Rama Cay.

Table 13. Pregnancy records from the Rama Cay clinic, period 1997-2008.

Year	Number of women	HRO	Mean Age (*)	SD	Born alive	Alive		Death		Sex not reported	<1 year old
						♂	♀	♂	♀		
1997	24	14	25.9	6.5	24	13	11				
1998	36	28	24.3	7.7	31	14	19	2	1	2	5
1999	30	14	22.5	8.1	30	18	12				
2000	27	21	22.5	5.4	25	12	13	1	1		2
2001	33	20	23.2	6.5	31	15	16	1	1		2
2002	12	10	21.6	5.4	12	4	8				
2003	16	16	23.3	6.4	16	7	9				
2004	20	17	23.5	6.5	19	6	13		1		1
2005	24	23	23.4	6.1	23	10	13	1			1
2006	15	14	23.6	7.3	15	10	5				
2007	29	17	23.6	5.4	28	12	16		1		1
2008	18	18	20.8	5.4	18	9	9				
Total	284	212	-	-	272	130	144	5	6	2	12

(\*)  $23.18 \pm 0.37$  (SE).

Based on the records from 1997 until 2008, a total of 284 women averaging 23 years of age were attended in the clinic. The majority of these women were under high risk obstetrics (HRO). A variety of maternal and fetal factors can produce a high-risk pregnancy such as younger age, mother's weight, and previous complications such as fetal loss and still births. None of these factors were specified in the clinical records. Table 13 illustrates the reduction in child mortality from 1997 until 2008.

Table 14. Regional maternal, fetal, and neonatal mortality rates (RAAS).

Mortality Rates	1996	1997	1998	1999	2000	2001	2002	2003	2004	2005
MMR	127.3	297.1	233.4	106.1	148.5	439.6	491.3	158.5	179.4	269.1
FMR	6.1	5.7	4.8	4.0	4.4	6.9	9.3	9.2	8.3	6.5
NMR	2.3	1.0	0.4	0.6	2.5	6.9	6.7	5.4	6.0	5.6
<i>Expected live births</i>	<i>4712</i>	<i>4712</i>	<i>4712</i>	<i>4712</i>	<i>3867</i>	<i>3867</i>	<i>3867</i>	<i>4416</i>	<i>4451</i>	<i>4458</i>

MMR= Maternal Mortality Rate, FMR = Fetal Mortality Rate, NMR = Neonatal Mortality Rate. Rates per 100,000. Source: MINSa

At the regional level (RAAS), maternal mortality (MMR) reached the highest rates in 1997, 2001, and 2002 and increased again in 2005. Rates of neonatal mortality (NMR) for newborns less than 28 days old and fetal mortality (FMR) have increased since 2001 (Table 14).

### Specific and Crude Mortality and Fertility Rates

Crude rates on infant mortality, fertility, and birth were calculated using MINSa's raw data collected at the *comarca* of Rama Cay between 2002 and 2009 (Table 15). Age-specific mortality rates (ASMR) were more frequent among children younger than 4 years of age in 2005, 2007, and 2008 as well as for 15 and more than 50 years old individuals in the 2002-2008 periods. Infant mortality rate (IMR) for children under one year of age was higher in 2004, 2005, and 2007 as was the crude death rate compared with other periods. This data shows that mortality rates were relatively low for children but higher for individuals older than 15 years at the *comarca* of Rama Cay from the year 2004 until 2008.

Table 16 includes the cause specific death ratios (CSDR) of the *comarca* of Rama Cay and the *municipio* of Bluefields from 2004 until 2008. Respiratory diseases and diarrhea are the main causes of death in the *municipio* of Bluefields compared to accidents and homicide in the

*comarca* of Rama Cay. As the table shows, the rate of homicides and accidents increased in 2007 and 2008 compared to previous years.

Table 17 displays two death records collected by the Moravian church at Rama Cay since 1975 and for the *comarca* of Rama Cay since 1993. Both records are associated with two different population aggregates. The Moravian Church annotated Amerindian casualties mostly from Rama Cay, and those collected by SILAIS includes communities geographically close to Rama Cay. The SILAIS records include Amerindians and other individuals not necessarily of Rama origin that inhabit the *comarca* of Rama Cay.

The health clinic at Rama Cay belongs to MINSA and was established in 1965. The clinic usually attends to respiratory diseases, malaria, and diarrhea in children, as well as dermatologic diseases and pre-natal and natal care. Seriously ill patients are transferred to the hospital in Bluefields. Herbal medicine is also provided by local bush doctors for different maladies such as snake bites (GTR-K 2007; Loveland 1976).



Table 15. Age structure and death rates of the *comarca* of Rama Cay.

Age group	2002	ASMR	2003	ASMR	2004	ASMR	2005	ASMR	2006	ASMR	2007	ASMR	2008	ASMR	2009
<1-4	209		233		246	0.4	220	1.5	242		267	0.9	241	0.9	243
5-9	227		254		268		240		263		282		250		250
10-14	246		276		290		260		285		286	0.4	274		272
15-49	1042	0.5	1168	0.5	1225	0.4	1098	1.5	1206		866	1.4	1080	0.9	1137
50+	171		191		201	0.4	180	1.5	197	0.5	443	0.9	214	1.9	180
Fertile women (15-49)	498		557		586		525		576		436		547		547
Total population	1895		2122		2230		1998		2193		2144		2059		2082
CDR		0.5		0.5		1.2		4.5		0.5		3.7		3.7	n/a
IMR		0		0		52.6		43.5		0		35.7		0	n/a
CBR		6.3		7.5		8.5		11.5		6.8		13.0		8.7	n/a

ASDR: Age-specific Death Rate, CDR: Crude Death Rate, IMR: Infant Mortality Rate [under one year of age], CBR: Crude Birth Rate. Source: Official statistical estimations (MINSa) for the *comarca* of Rama Cay.

Table 16. Caused specific death ratios at the *municipio* of Bluefields and the *comarca* of Rama Cay.

CSDR	2004		2005		2006		2007		2008	
	Municipio	Comarca	Municipio	Comarca	Municipio	Comarca	Municipio	Comarca	Municipio	Comarca
Total	24	3	28	9	18	1	28	8	22	8
Diarrhea	8 (33.4)	-	10 (35.7)	-	14 (77.7)	-	7 (25)	1 (12.5)	5 (22.7)	-
Respiratory	11(45.8)	2 (66.6)	15 (53.5)	1 (11.1)	3 (16.6)	-	15 (53.5)	-	14 (63.6)	3 (37.5)
Accidents/homicide	4 (16.6)	1 (33.3)	3 (10.7)	4 (44.4)	-	1 (100)	6 (21.4)	4 (50)	2 (9.1)	4 (50)
Other	1 (4.2)	-	-	4 (44.4)	1 (5.55)	-	-	3 (37.5)	1 (4.5)	1 (12.5)

Source: MINSa (SILAIS/RAAS): The *comarca* includes: Rama Cay, Sumu Kat, Zompopera, Wining kay, Indian River/Graytown, Yaladina, Torsuany, Colorado, Domuko, Grenada, Santa Elisa, Las Cuevas, El Pavón, El Guirón, La Cuna (rates per 1000).

Table 17. Death records according with the Moravian Church and the clinic at Rama Cay.

Year	Moravian Church records		Rama Cay (comarca)†		Death <15 year old	
	Male	Female	Male	Female	Male	Female
1975-1979	2	3	-	-	-	-
1980-1989	21	19	-	-	-	-
1990-1999	30	23	10	5	2	4
2000-2009	18	6	25	13	7	7
Total	71	51	35	18	9	11

(†) Records from 1993. Data from SILAIS (Rama Cay clinic).

### Effective Population Size ( $N_e$ )

The effective population size of 278 was calculated from 868 breeding adult individuals between 15 and 45 years of age with an average number of births of 6.2. This number is one fifth of the actual population size of 1430 individuals and around one third of the breeding adults in the population. The effective population of the Rama means that the effect of genetic drift will accumulate at the same rate as a population of 278 individuals.

### Opportunity for Natural Selection

Mean life births, variance, and Crow's indexes of selection of the Rama are presented in table 18. The value for the total index of natural selection ( $I$ ) for the period between 2004 and 2008 is 0.32. The fertility and mortality component of Crow's index is 0.23 and 0.58, respectively. Because the contribution of fertility to the total index is greater than the contribution of mortality for the Rama, fertility contributes the most to natural selection. The high fertility index may be due to the improvement of reproductive health in the last six years

compared to the period between 1980 and 1999 when mortality of children younger than 15 years was higher. The difference in mortality suggests that the opportunity for natural selection might have changed in the last decade due to the change in population composition. The Rama obtained similar Crow's index values to the Teribe ( $I = 0.378$ ), the Bribri ( $I = 0.362$ ), and the Huetar ( $I = 0.298$ ) from Costa Rica (Barrantes 1993) but these values might have changed in recent years. High values are common among agriculturalists ( $> 1$ ) and small opportunity for natural selection indexes are expected in hunter gather societies when they present high fertility and low mortality indexes (Crawford 2001).

Table 18. Crow's indices of fertility, mortality and total selection potential of the Rama Amerindians between 2004 and 2008.

Crow's Index	Variable	Period (2004-2008)
Mortality component		
Number of live births	$n$	23
Proportion surviving > 15y.	$P_s$	0.82
Proportion dying < 15y.	$P_d$	0.18
Selection Index (mortality)	$I_m$	0.23
Nativity component		
Number of deaths	$n$	100
Average number offspring (at 49 y.)	$\mu$	6.193
	$\mu^2$	38.04
Variance in number of live births	$\sigma^2$	22.7
Total		
Selection index (fertility)	$I_f$	0.58
	$I_f/P_s$	0.71
Total index of natural selection	$I$	0.32

## Health and Disease among the Rama

Table 19 compares the incidence rate of diseases from 2002 and 2008 in the Rama Cay clinic and the *comarca* of Rama Cay. According to the records, the most commonly consulted diseases in the *comarca* were pneumonia, common cold, and bronchitis. In 2007, rates of these diseases in the *comarca* went down to 200 cases per 1000 inhabitants. In Rama Cay, rates of respiratory infections were regular, varying between the lowest rate of 105 in 2003 and 173 in 2006, showing a different trend from the *comarca*.

Table 19. Incidence rates of diseases consulted and diagnosed at the clinic and the *comarca* of Rama Cay.

Type of disease	Incidence Rate for Acute and Chronic Diseases						
	2002	2003	2004	2005	2006	2007	2008
Respiratory (1)	147.2	105.1	148.8	147.6	173.7	170.7	118.1
Respiratory (2)	-	-	217.9	243.2	308.2	487.4	196.2
Malaria (1)	31.1	16.9	4.4	8.0	9.5	4.2	0.00
Malaria (2)	-	-	7.17	25.03	21.8	1.4	0.00
Diarrhea (1)	34.8	17.4	17.4	26.5	36.0	259.3	45.2
Diarrhea (2)	-	-	39.4	50.5	80.2	55.0	51.4
Parasitosis (1)	91.8	38.2	55.2	61.5	49.7	58.7	54.4
Skin diseases (1)	65.9	44.7	40.8	37.5	36.0	19.1	27.6
UTI (1)	42.7	28.7	26.5	24.0	31.0	16.7	58.7
Arthritis (1)	34.30	31.10	33.18	25.03	17.33	21.46	7.77

(1) Consulted in the clinic of Rama Cay, SILAIS. (2) Confirmed cases in the *comarca* of Rama Cay, MINSA. Rates per 1000. Note: Because the uncertainty of the population size of the island of Rama Cay previous to this research, rates were calculated using the population size per year of the *comarca*. Thus, incidence rates of disease must be higher than the ones calculated here.

Infections due to intestinal parasites and acute diarrhea were steady in the *comarca* with an average rate of 55 for diarrhea and 47 per 1000 habitants for parasitoid infections between

2004 and 2008. In the island of Rama Cay, diarrhea reached its highest rate in 2007 with 200 and then went down to 45 in 2008. Rates of urinary tract infections were steady between 2003 and 2007 but increased in 2007 the same year hurricane Felix hit the coast (Fig.16).

Vector-borne diseases such as malaria went down to rate zero in the *comarca* and the island of Rama Cay due to the effective epidemiological control in the Caribbean region (PAHO 2007). Finally, arthritis went down in the period of seven years in the Rama Cay clinic.

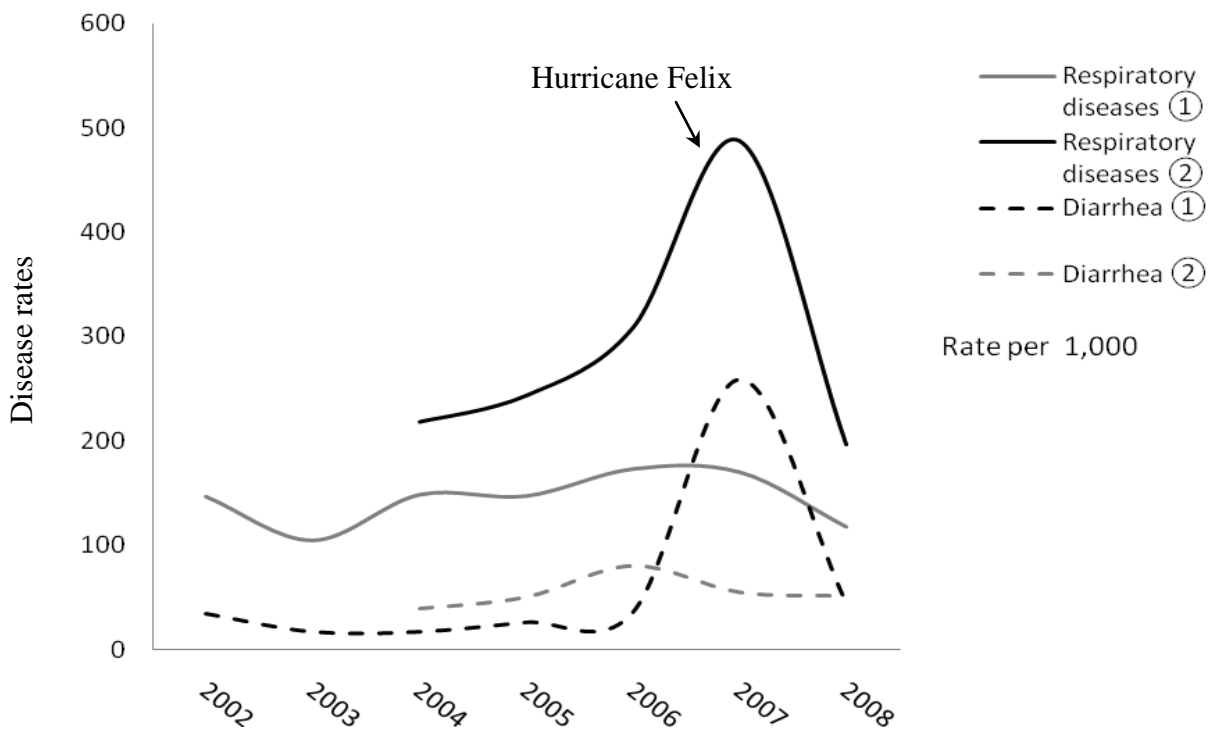

Figure 16. (1) Diseases consulted in the clinic at Rama Cay; (2) Diseases diagnosed for the *comarca* of Rama Cay.

Information on mortality for the period between 1975 and 2008 documented by the Moravian Church at Rama Cay shows that natural disasters and political conflicts were likely

mortality determinants (Fig.17). The first important mortality event happened during the Nicaraguan civil war during the 1980s when a Sandinista air strike against Rama Cay in 1984 devastated the island (Riverstone 2004); the second important event was associated with hurricane Joan in October of 1988. Joan was category 4 hurricane —5 is the maximum category— that caused major infrastructure and human casualties in the southern Caribbean region of Nicaragua (ERN-CAPRA 2011). Between 1993 and 1994 a cholera outbreak at Rama Cay was related with high mortality. In 1998 hurricane Mitch, category 5, violently destroyed the island, elevating human casualties by its direct and indirect effects. In the year 2007 hurricane Felix of category 5 hit the Miskito coast and diseases augmented, especially at the *comarca* of Rama Cay.

In the Caribbean region, Mitch impacted 14 *municipios*, causing missing residents and 2823 confirmed fatalities. The outbreak of cholera in the region caused 36 fatalities (PAHO 2003). After this disaster, mortality declined to six persons between 2003 and 2004 among the Rama. In comparison to the Moravian Church records, official reports provided by MINSA of the causes of death between 1993 and 2008 in the *comarca* shows a peak of mortality associated with hurricane Mitch in 1998. A trend of increased mortality emerges between 2005 and 2008 when there were 22 human casualties, among the causes of death the most common were homicide (6 cases), respiratory diseases (5 cases) and “other causes” (6 cases).

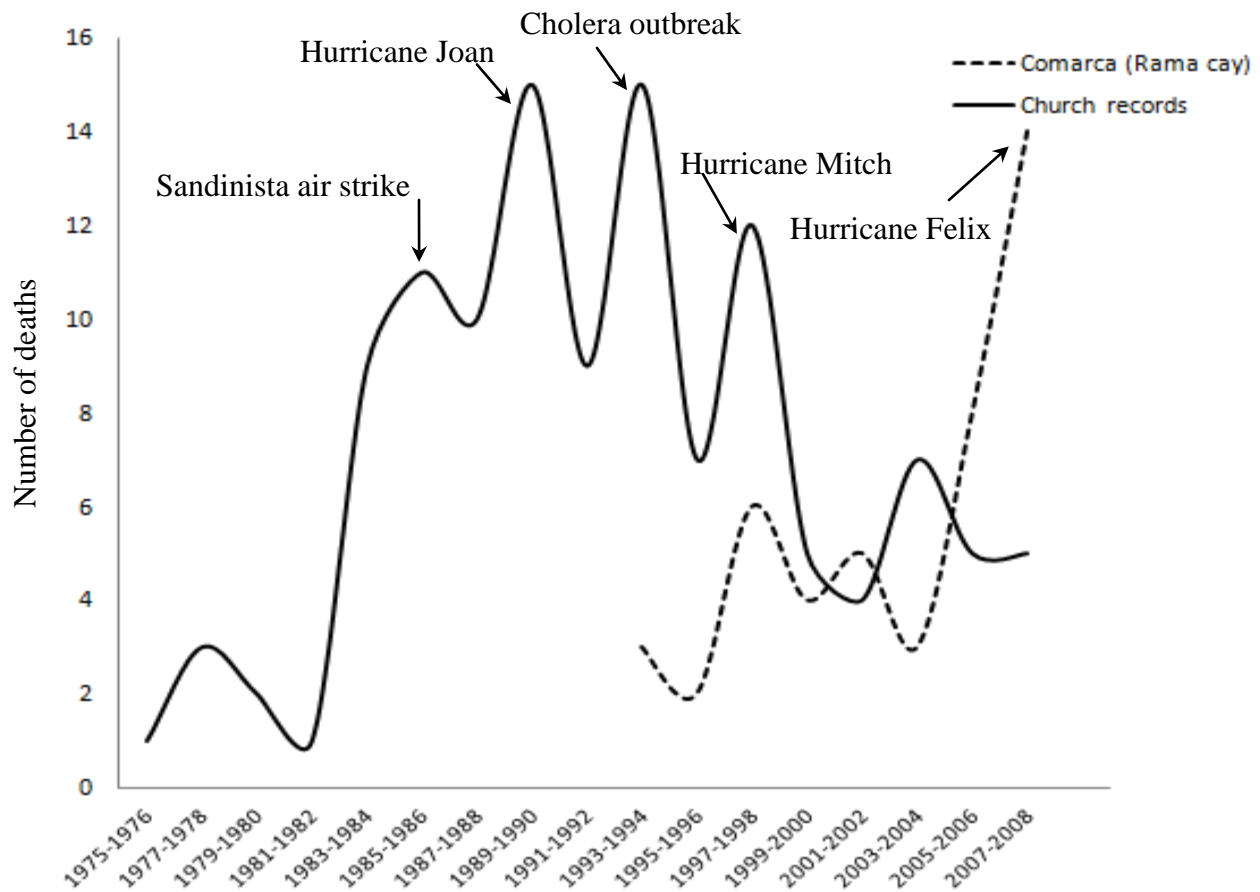

Figure 17. Number of deaths according with the Moravian Church and information from the clinic at Rama Cay and recent historical events.

### Age and Sex Structure at the Southern Atlantic Autonomous Region (RAAS)

For Southern Nicaragua (RAAS), population projections were estimated using the 7th National Census of Population in Nicaragua 2005 and the demographic and health survey 2006-2007 (INIDE 2008b; INIDE 2008d). Unlike population growth pyramids of previous years, the RAAS 2012 pyramid reveals a broadening of the base in the segment of the population less than 14 years of age (Fig.18). The broadening of the base was caused by the survivorship of this

segment of the population and a projected decline in fertility rates to 2.55 children per woman between 2010 and 2015 in Nicaragua. The estimated fertility rate for the RAAS in the year 2005 was 4.33 but it is expected to be lower in the following decades as is the rate of population growth. Estimated at 1.54 between 2010 and 2015, it's expected to decline in the following years (INIDE 2008c; INIDE 2008d).

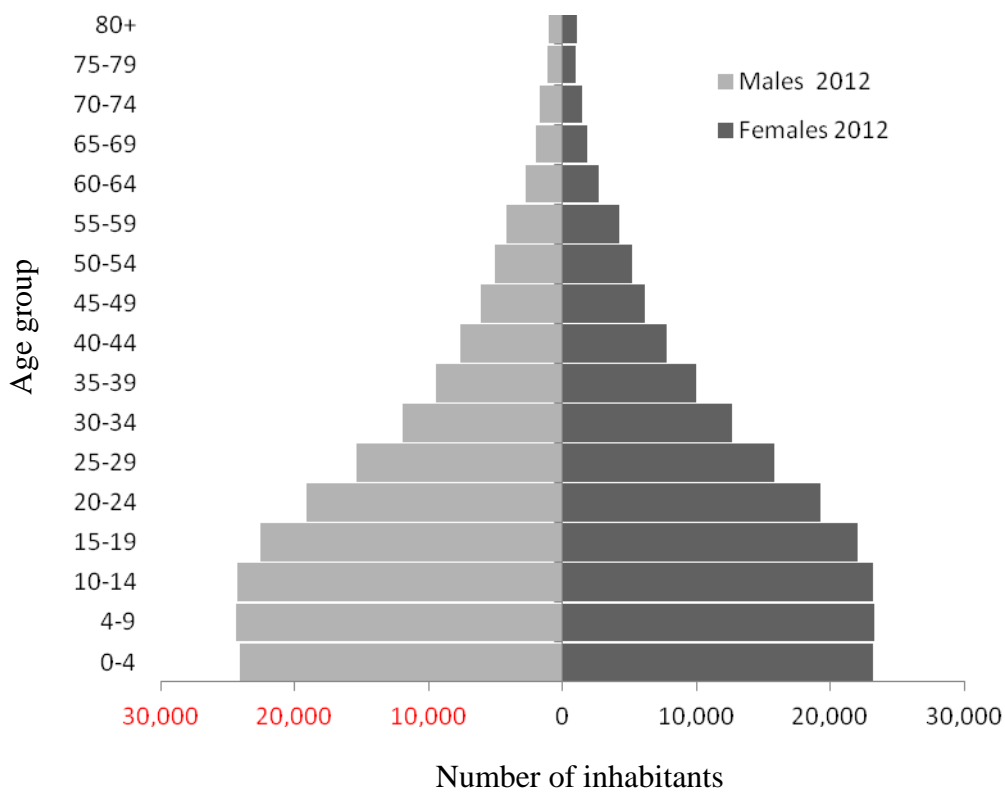

Figure 18. RAAS Population pyramid for 2012 based on INIDE (2008d).



## Disease Prevalence at RAAS

In Nicaragua, acute respiratory infections were the most common infectious disease between 1997 and 2000 (PAHO 2003). During hurricane Mitch, respiratory diseases and acute diarrhea had their highest prevalence in the region. In the southern Caribbean region, respiratory infections have fluctuated since 1997 but increased in the year 2007 with hurricane Felix. Diarrhea and pneumonia were steady with rates less than 1000 per 10,000 inhabitants (Fig.19).

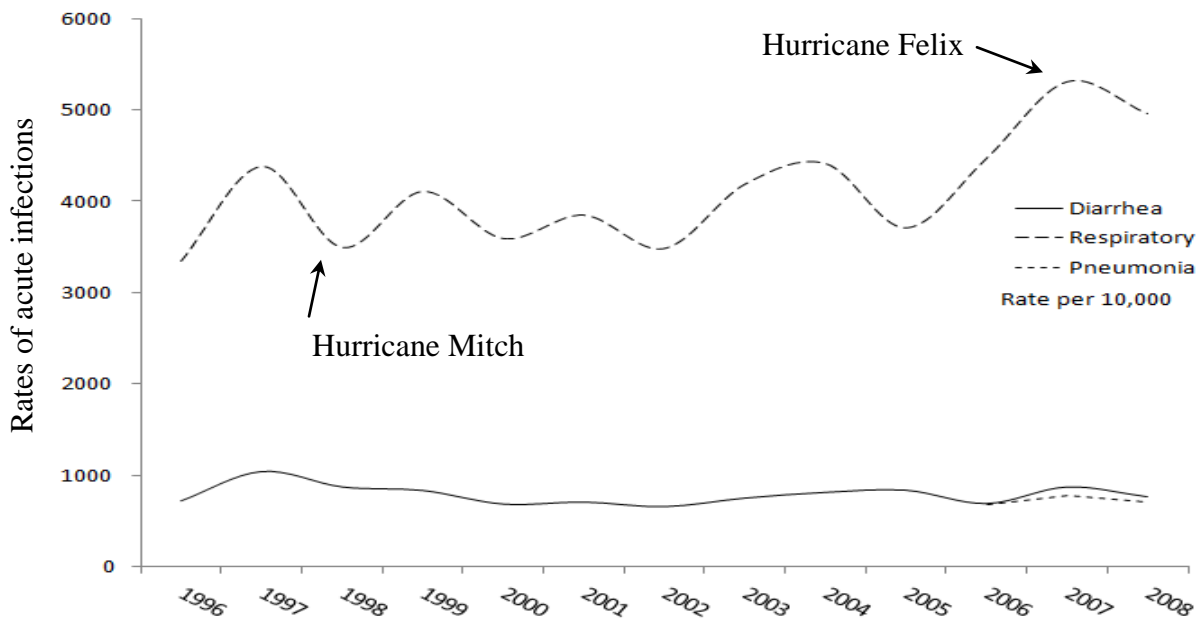

Figure 19. Prevalence of acute infections in the southern Caribbean region of Nicaragua (RAAS).

Figure 20 shows less than 5 per 10,000 individuals were affected by pesticide poisoning and snake bites at RAAS. Food poisoning was high after the hurricane Mitch in 1998 and increased even more between 2006 and 2008 when hurricane Felix hit the coast in 2007.

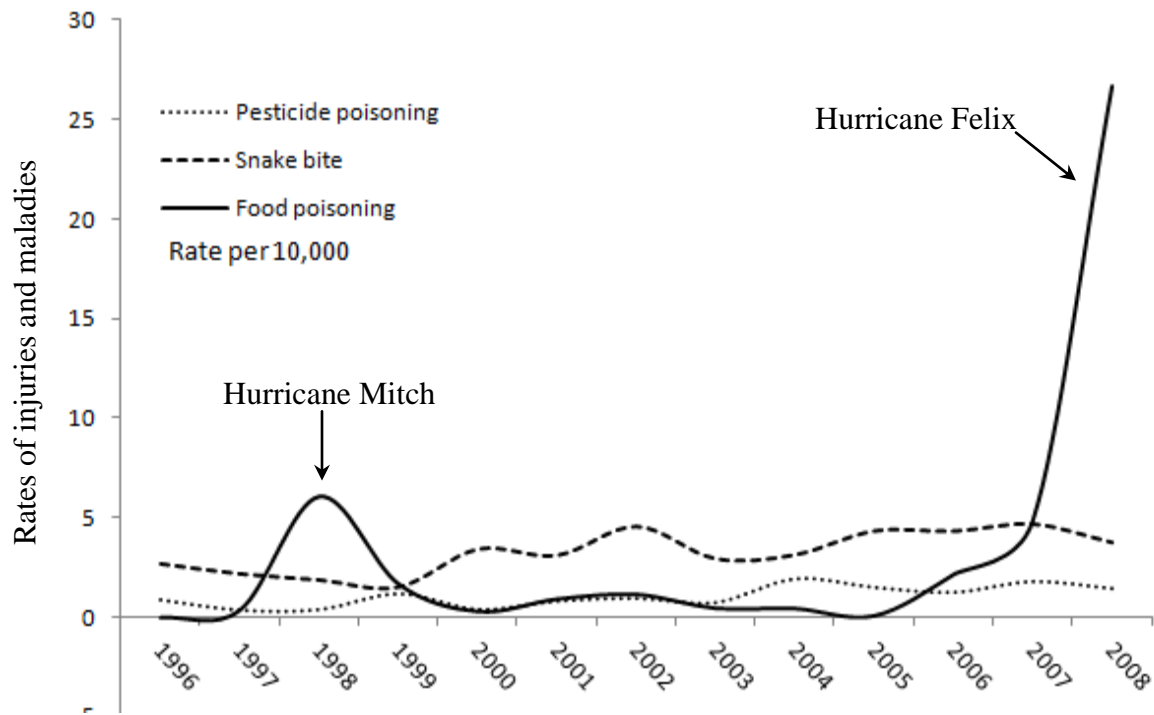

Figure 20. Less frequent injuries and maladies at RAAS.

Figure 21 shows the less prevalent diseases in the southern Caribbean region of Nicaragua: meningitis, cholera, and leptospirosis, a disease transmitted to people when water that has been contaminated with animal urine, from rats for example, comes in contact with humans (Langston and Heuter 2003). A leptospirosis epidemic was endemic in Nicaragua between 2001 and 2005 (PAHO 2007). In 1998 due to flooding caused by the Hurricane Mitch, 705 suspected cases were reported in the Caribbean coast (PAHO 2003). Leptospirosis rates went up after 2000 and fluctuated in the following years. Meningitis is an inflammatory disease of the brain and spinal cord, and is caused by viruses, bacteria and other microorganisms (Sáez-Llorens and McCracken 2003). At RAAS, meningitis had its highest rate in 1999 and went down in the

following years. Rates on cholera fluctuated after 2000 but in general are low. Other “new,” known and unknown diagnosed diseases are getting higher rates, for example, HIV, AIDS. An increase of these new infections is associated with the Miskito coast landfall of Hurricane Felix.

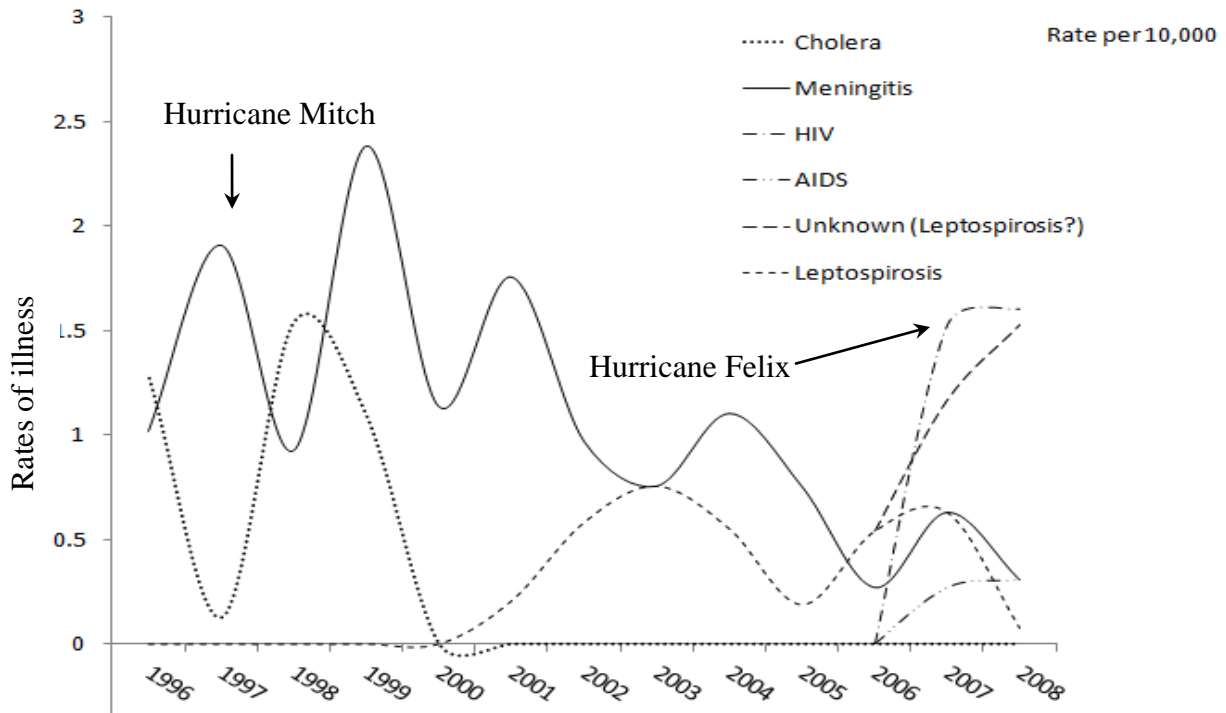

Figure 21. Less frequent and new illness at RAAS.

### Vector-borne Diseases at RAAS

According with (PAHO 2003) the largest index of malaria cases reported in Nicaragua was in 1996. In the southern Nicaraguan region this trend is exemplified in figure 22 which shows that the protozoan parasite that causes a type of malaria, *Plasmodium vivax*, was higher

compared to second type, *Plasmodium falciparum*. Both types increased after hurricane Mitch hit the coast in 1998. Incidence of Malaria Vivax was also higher than malaria Falciparum between 2004 and 2005 and both decreased to zero in 2008. While both types of malaria reached their lowest rate between 2001 and 2002, other vector-borne diseases transmitted by mosquitoes of the genus *Aedes*, such as the classical dengue virus, increased. Other zoonoses such as rabies have been increasing slowly yet steadily at a rate of less than 40 per 10,000 individuals.

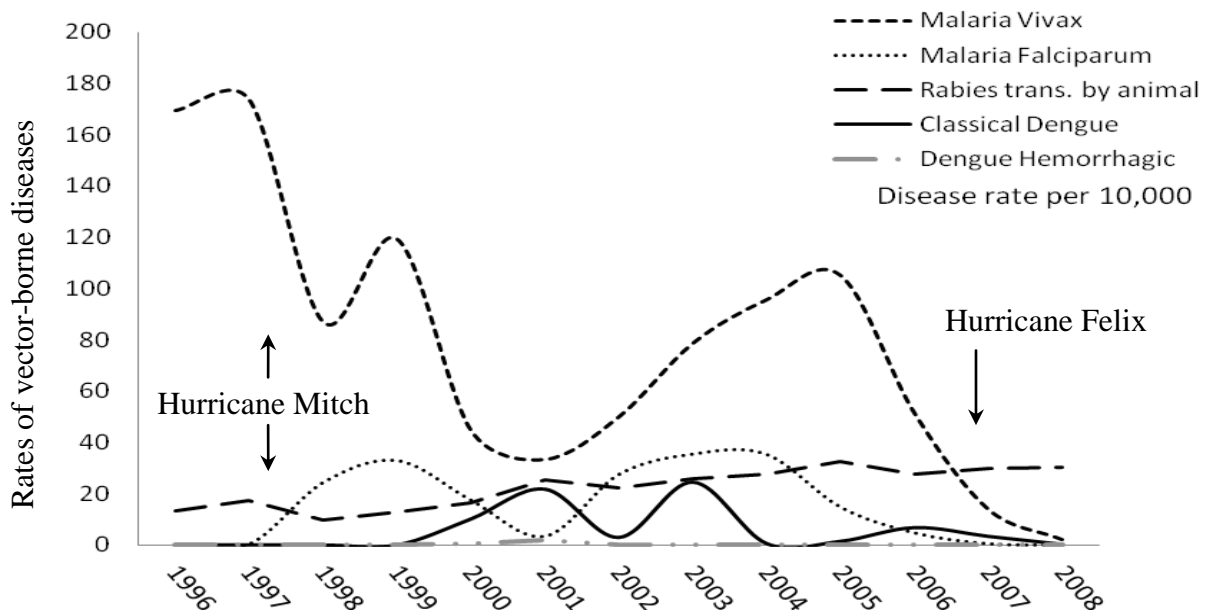

Figure 22. Diagnosed cases of vector-borne diseases at RAAS.

### Causes of Death at RAAS

As a whole, the largest numbers of deaths in RAAS from 1996 until 2008 were attributed to diarrhea, with a noticeable increase of cases during the time period after hurricane Mitch.

Rates of respiratory disease also escalated during this time period and peaked in 2003, after which reported deaths from respiratory disease slowly decreased, maintaining rates between 10 and 14 cases per 100,000 at the end of the period. Less frequent diseases such as dengue, malaria, meningitis, and leptospirosis account for the fewest human casualties (Fig.23).

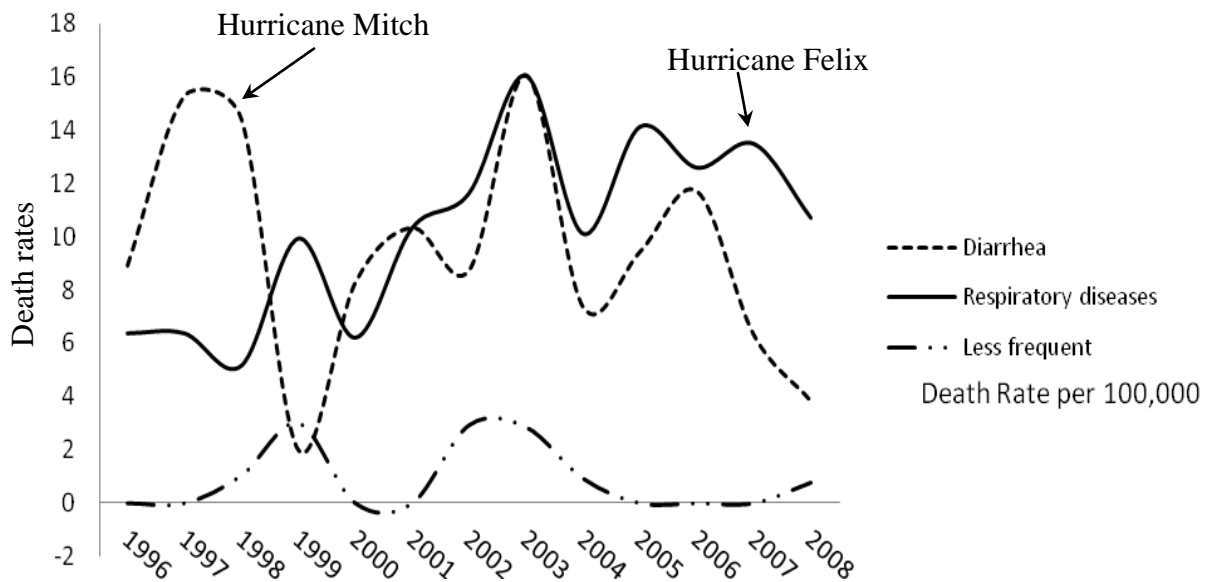

Figure 23. Death rates at the southern Caribbean Nicaragua (RAAS).

Other less frequent causes of mortality are pesticide poisoning and snake bite which each reached their highest rates in 2002. While snake bites subsequently declined, pesticide poisoning increased between 2006 and 2007, and then decreased in 2008 (Fig. 24).

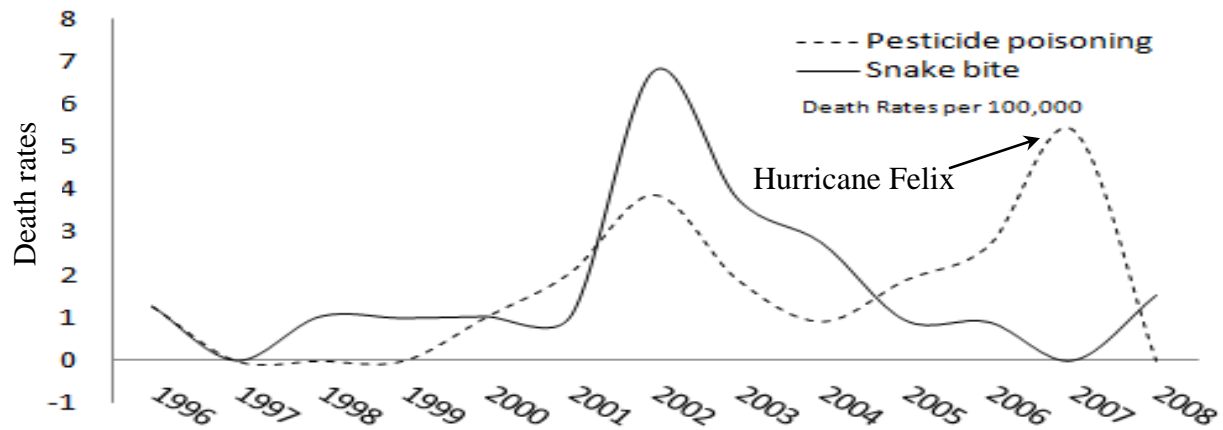

Figure 24. Less frequent causes of death (RAAS).

### Time Series Analysis on Mortality

In order to examine if mortality is increasing over time, a regression analysis using the least square method was performed for different population aggregations: RAAS, the *comarca* of Rama Cay from 1996 until 2008, and records from the Moravian Church from 1975 until 2008. Table 20 shows the results of the analysis of variance for different levels of population aggregation. In general, all populations except for the Moravian records (1996-2008) indicate that the relationship between calendar years and mortality was statistically significant at alpha-level 0.05, demonstrating that death rates are increasing with time. The  $R^2$  value obtained for RAAS indicates that 60.4% of the variance in deaths is explained by the year of occurrence; however, the  $R^2$  value is lower for the other populations (~20/35%). Except for the quadratic regression from the Moravian records between 1975 and 2008, all fitted regression lines were linear.

Table 20. Analysis of variance and regression diagnostics.

Level of aggregation	DF(total)	SS (total)	MS	F-ratio	P-value	R <sup>2</sup>
RAAS	12	7925.2	4782.9	16.7	0.002	60.4%
Rama Cay (comarca)	12	119.2	37.8	5.1	0.045	31.7%
Rama (Moravian records[1996-2008])	12	56.7	11.6	2.8	> 0.05	20.5%
Rama (Moravian records[1975-2008])	31	227.4	39.3	7.6	0.002	34.6%

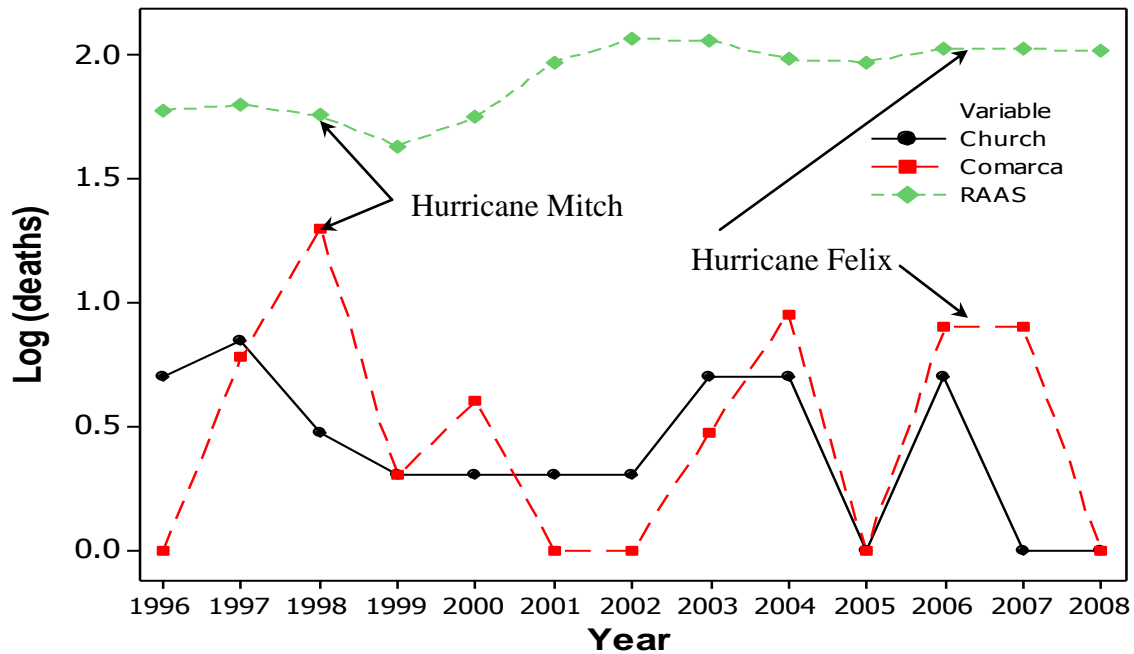

Figure 25. Logarithmic transformation of the number of deaths per year for three population aggregations. Notice that picks in mortality are associated with environmental disasters.

Figure 25 represents the mortality trends of three population aggregates between 1996 and 2008. Mortality patterns are somewhat different between RAAS and the *comarca* and the Church records from Rama Cay. Similarly high peaks were present between the *comarca* and the church.

The resulting cross-correlations between these three populations (not shown) indicated that only the *comarca* and the Moravian Church between 1996 and 2008 were correlated. Figure 26 shows that both series (church and *comarca*) are stationary and that the number of deaths per year are also correlated. Value at Lag 1 of  $-0.67 > -0.60$  is significant ( $\alpha = 0.05$ ), indicating a negative correlation of both series. The following lags are moderate indicators of the next periods, that is changes in mortality are associated with future years (cf. Vandaele 1983).

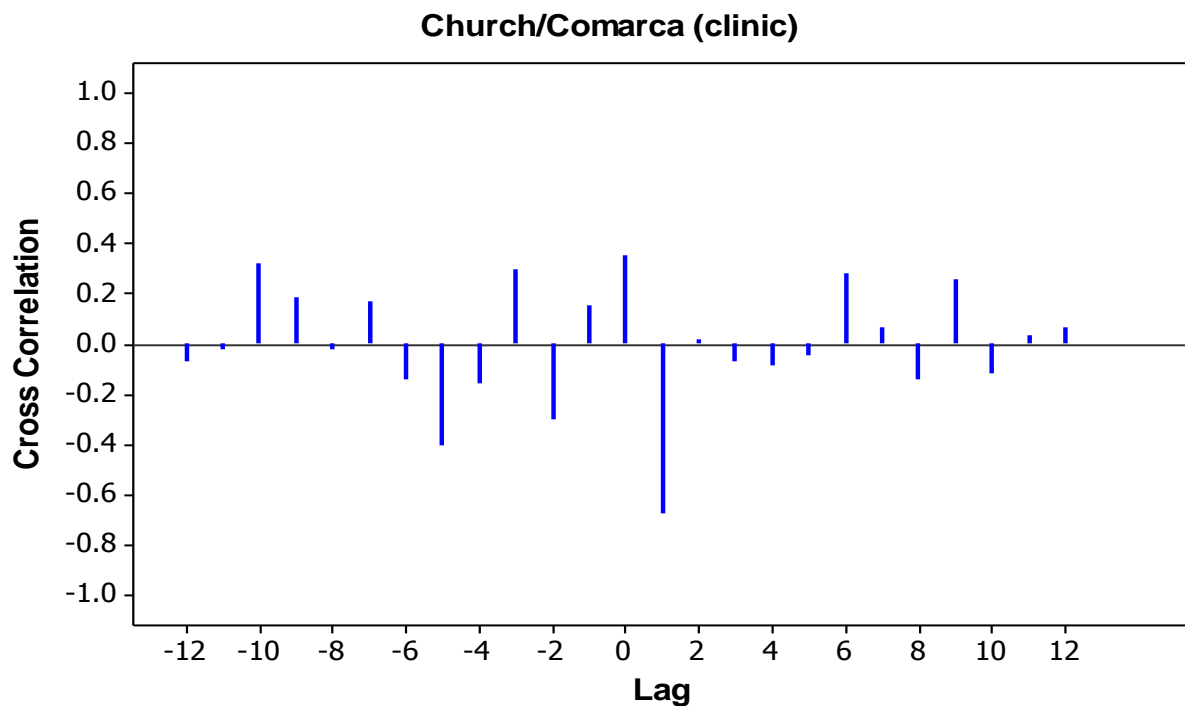

Figure 26. Cross-correlations between mortality data from the *comarca* of Rama Cay and the Moravian Church.



## ARIMA Time Series Model

In order to remove the quadratic trend of the mortality data (not shown) and make it stationary, data was differentiated twice. The value obtained from the differentiation procedure of this analysis was excluded from the final model. The partial autocorrelation (PACF) showed a decaying pattern and a large Lag 1. The auto-regressive function (Fig.27) obtained a large negative autocorrelation at Lag 1 (-0.55) associated with a T-ratio of -2.96, and a Ljung Box Statistic (LBQ) value of 9.73. The LBQ value was large enough for rejecting the null hypothesis that all lags equal zero. Together these values suggested an ARIMA ( $p, d, q$ ) of  $(0, 0, 1)$ .

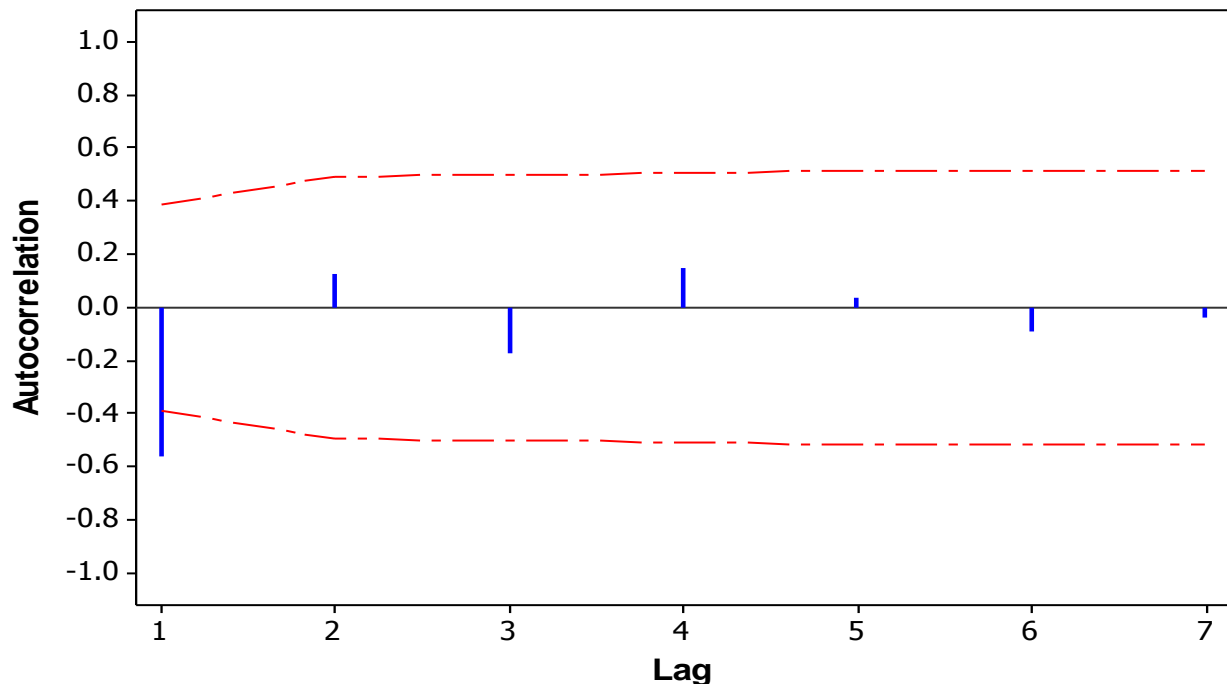

Figure 27. ACF for mortality records. Lines are between 5% confidence limits.

ARIMA (0, 0, 1) was the best fitted model as indicated by the moving average parameter of 0.9485 which is significantly different from zero at  $\alpha = 0.05$ , with a T-ratio of 4.80 ( $p < 0.001$ ). Because the moving average parameter is between the 95% confidence lines, the component is not auto-regressive. The LBQ statistics for Lag 12 ( $p = 0.54$ ) and Lag 24 ( $p = 0.42$ ) compared with other models shows that residuals (the difference between actual and predicted values) only represent random errors and all the autocorrelations fall within the 95% confidence intervals. The final model shown in figure 28 indicates that mortality in one year is influenced by random events from the current and preceding years.

The increase in mortality can result from cultural or environmental factors such as war and overcrowding or from natural events such as hurricanes that influence mortality in subsequent years. Environmental degradation and natural disasters such as hurricanes are known to increase the vulnerability to disease and mortality in human populations. For example, after hurricane Mitch struck Nicaragua in 1998, an outbreak of cholera affected the region. In the last decades, hurricanes, floods and food emergencies have occurred, mainly in the Caribbean region (PAHO 2003; PAHO 2007). Bluefields and Rama Cay were among the most impacted localities.

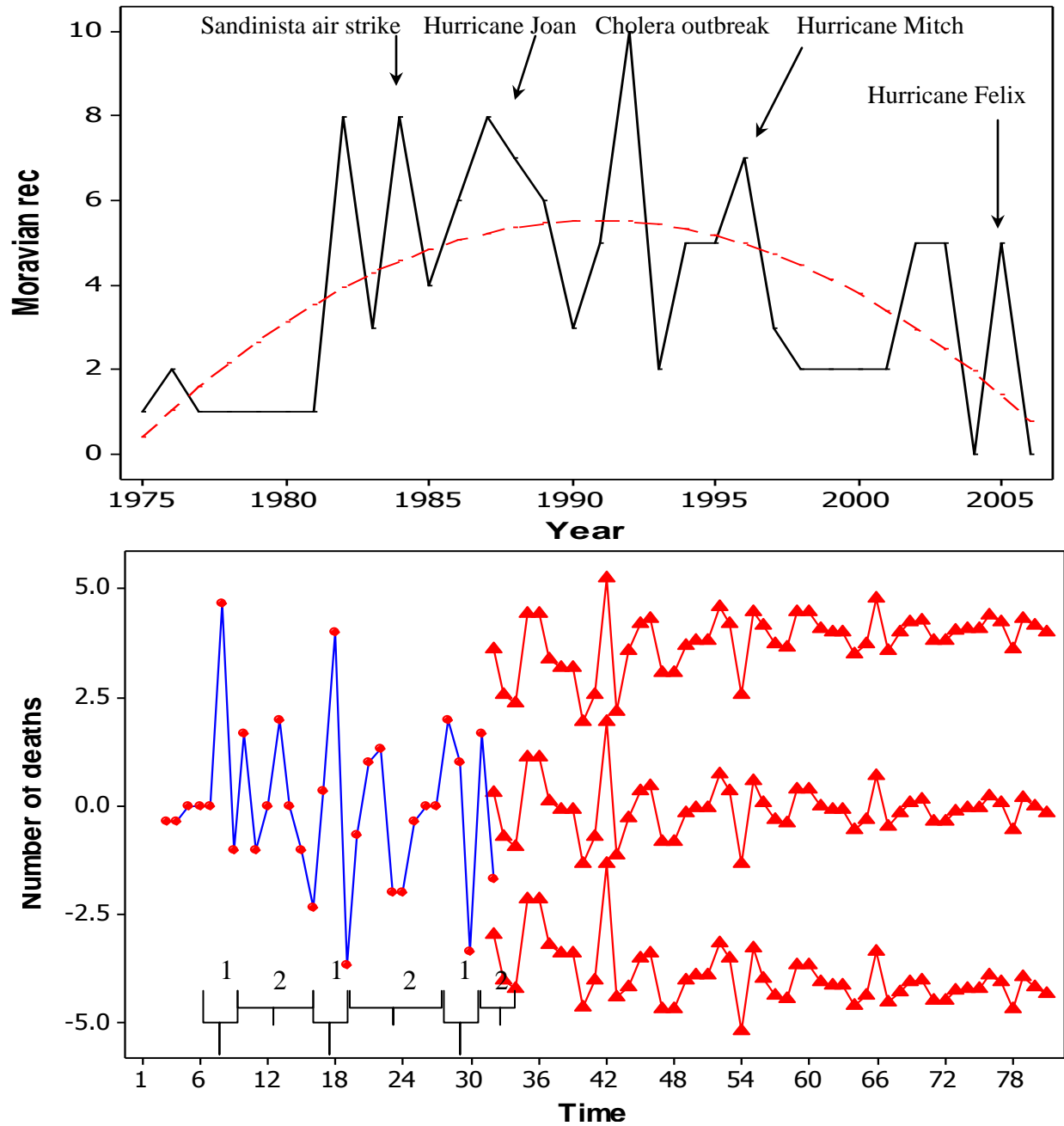

Figure 28. Top graph: secular trend of mortality and fitted quadratic curve ( $Death = -0.28 + 0.691 \cdot year - 0.02054 \cdot year^2$ , MAPE = 70.8, MAD = 1.8, MSD = 4.6). Lower graph: ARIMA model (0, 0, 1). Number 1 in the graph represents a higher peak in mortality every ~7-8 years; number 2 represents subsequent peaks in mortality every ~ 3 years. Broadcasting represents peaks in mortality patterns if similar environmental conditions are present in the southern Moskitia of Nicaragua.

## ***SURNAME ISONYMY***

Isonymy methods were used to approximate the effect of geographic isolation on the population structure of the Rama. This analysis includes test statistics for inter- and intra-population variation, kinship affinity, mate behaviours, and isolation by distance.

A total of 592 surnames were tested for intra-population variation, including coefficients of Isonymy ( $I$ ), Lasker's coefficient of relationship by isonymy ( $R_i$ ), kinship within populations ( $\Phi_{ii}$ ) and diversity values ( $\alpha$ ). Inter-population variation was approximated using Lasker's coefficient  $R_{ib}$ , Isonymy ( $I_{ij}$ ) and kinship values ( $\Phi_{ij}$ ) between populations. Population structure was investigated using the repeated surname approach ( $RP$ ) and consanguinity estimates ( $F$ -statistics). Isolation by distance was determined by using Lasker's distances ( $D$ ), Euclidean distances ( $\theta$ ), Lasker's coefficient of relationship between populations ( $R_{ib}$ ), and a geographic distance matrix (in km). These matrices were tested for correlation with each other using the Mantel tests (Mantel 1967).

### **Surname Distributions**

Spanish and Creole surnames from communities such as Rama Cay, Punta Aguila, and Greytown have absolute scores between 0.5 and 1 in the scale of specificity, being the most specific to a location those surnames that score between 0.5 and 1. The same trend of Spanish and Creole surnames was found in less populated communities, scoring between 0.2 and 1. However, high specificity in these communities is caused by their low frequency (Table 21). This is opposed to the scenario in which a high frequency of surnames in some communities score lower in specificity; thus, specificity is inversely related to its frequency. In order to test

this observation, a chi-square test ( $X^2$ ) was performed between surname frequencies and their level of specificity. The null hypothesis that there is a lack of association between these two variables was rejected ( $X^2 = 659.2$ ,  $df = 23$ ,  $p < 0.001$ ). Thus, it is likely that “founding” surnames were more diffused between communities and consequently are less specific. For example, the surname Macrea is highly frequent in most Rama communities, and therefore it is less specific within each community. In Rama Cay, where this last name is more frequent, it only reaches a specificity of 0.3 (Table 22). Contrary to this, uncommon last names of “recent” Spanish or Creole origin are highly specific to some communities but very low in frequency across all communities. This observation is consistent with the kinship networks between communities where “founding” surnames have more intra- and inter-community links. On the other hand, genealogies in which surnames are of “recent” origin have less linkage relationships between communities. In Sumu Kat, for example, the surname Macrea represents 44% of the total surnames sampled, and in Zompopera Macrea and Ruiz is 38%.

Table 21. Less frequent surnames in Rama communities.

Community	Frequency of surnames	Specificity	Possible surname origin
Greytown	17	0.5-1	Creole/Spanish
Rama Cay	16	0.5-1	Spanish
Punta Aguila	10	0.5-1	Spanish
Zompopera	5	0.25-1	Creole/Spanish
Sumu Kat	4	0.20-1	Spanish

Table 22. Top thirty more frequent surnames in seven Rama communities.

Surname	Absolute Frequency		Specificity	Location
	Local	Total		
Billis	3	3	1.00	Punta Aguila
Francis	3	3	1.00	Rama Cay
Levis	3	3	1.00	Punta Aguila
Santos	3	3	1.00	Greytown
Aragon	3	4	0.75	Greytown
Gonzalez	4	4	1.00	Greytown
Alvares	3	5	0.60	Greytown
Duarte	3	5	0.60	Greytown
Walter	3	5	0.60	Rama Cay
Flores	5	7	0.71	Greytown
Gomez	3	7	0.43	Zompopera
Budier	6	8	0.75	Sumu kat
Thomas	6	8	0.75	Zompopera
Wilson	3	8	0.37	Punta Aguila
Solano	5	9	0.55	Zompopera
Espinoza	5	10	0.50	Greytown
Omier	8	10	0.80	Rama Cay
Secundino	8	10	0.80	Rama Cay
William	5	11	0.45	Rama Cay
Benjamin	5	12	0.42	Punta Aguila
Blayat	9	12	0.75	Zompopera
Luna	7	13	0.53	Greytown
Hernandez	8	18	0.44	Greytown
Salomon	11	23	0.47	Greytown
John	11	31	0.35	Rama Cay
Martinez	13	31	0.41	Rama Cay
Hodgson	18	35	0.51	Rama Cay
Daniel	21	36	0.58	Rama Cay
Ruiz	14	39	0.35	Zompopera
Macrea	42	137	0.30	Rama Cay

## Marital Migration and Mate Choice

Table 23 condenses the geographic information and distances in kilometers from Rama Cay to other communities visited during fieldwork. Distances were measured “as the crow flies”. On average, 94% of the inhabitants were born within the Rama territory. The remaining percentage (6%), are either non-Rama individuals who married an individual of Rama ancestry or non-Rama immigrants from outside the Rama territory. The table also shows that married individuals born within the Rama territory traveled as far away as 100 kilometers to relocate to other Rama communities.

Table 23. Geographic positions and marital distances.

<b>Rama Community</b>	<b>Geographic Coordinates</b>	<b>Distance from Rama Cay (km)</b>	<b>% Both partners were born in the Rama territory</b>	<b>% At least one partner was born outside the Rama territory</b>
Sumu Kat	N 11 47 21.21 W 84 3 42. 81	29.48	94.7	5.3
Bluefields	N 12 0 23.47 W 83 45 43.48	14.65	100	0
Punta Aguila	N 11 34.240 W 83 43.326	35.64	93.1	6.9
Greytown	N 10 56.701 W 83 43.917	103.99	93.6	6.36
Indian River	N11 06.148 W83 54.206	86.59	94.7	5.27
Zompopera	N11 53.705 W83 56.114	13.91	84.6	15.39
Rama Cay	N11 52.926 W83 48.493	0	96.2	3.83

Premarital residence is illustrated in figure 29 which shows that the majority of individuals were born in Rama Cay and then migrated off the island (~50% and >80%). Around 10% remain within the same community (Sumu Kat and Zompopera, and Rama Cay). Around 40% (Punta Aguila) and 15% (Greytown) of individuals were born in other Rama communities different than Rama Cay. Finally, individuals born outside the actual limits of the Rama territory represent less than 5% of individuals in the majority of communities.

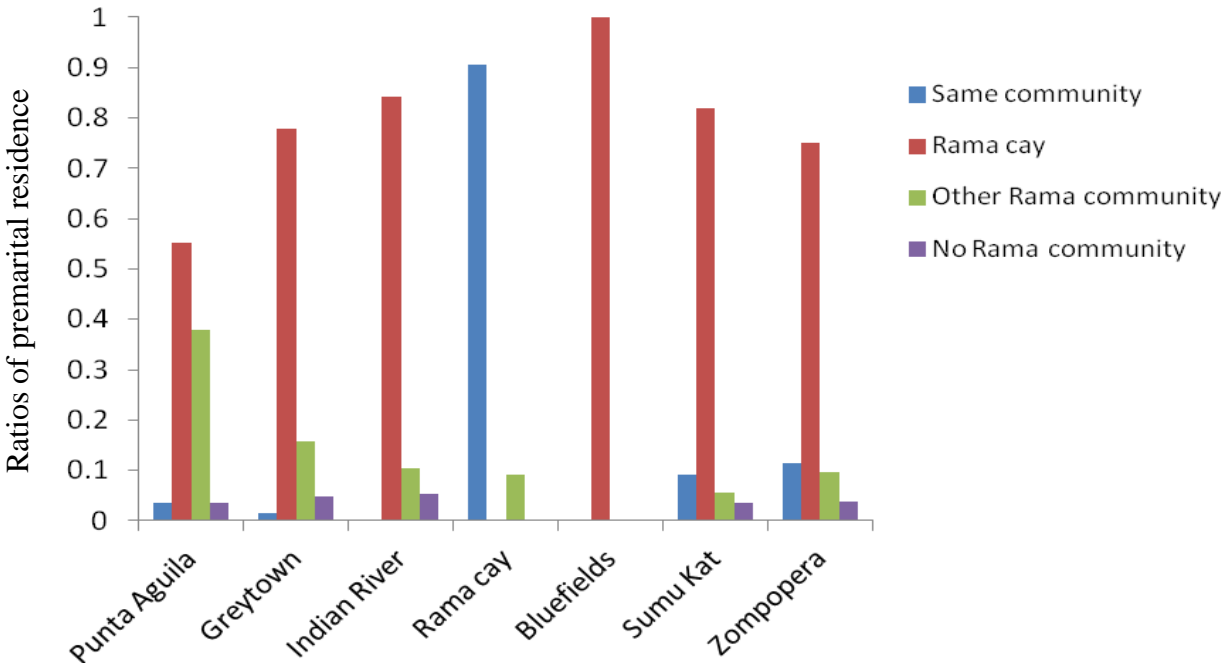

Figure 29. Ratios of premarital residence. Between 52% and 100% of individuals in most of the communities were born in Rama Cay and migrated out. 11% of individuals were born and stayed in Zompopera. In Punta Aguila, 40% come from other Rama communities.

This migratory pattern is resumed in the neighbor joint tree on the migration matrix (Table 24, Fig.30). The tree shows that all communities were populated by migrants from Rama Cay but in different proportions, for example, 100% of the Rama inhabitants in Bluefields were



born in Rama Cay. This proportion varies among the other five Rama communities. Greytown and Indian River have the most individuals born outside the Rama territory, such as in Managua and Limón, Costa Rica. Punta Aguila has the most individuals born in other surrounding Rama communities such as Cane Creek, Torsuani River, Red Bank, and Wiring Cay.

Table 24. Migration Matrix for Rama subpopulations.

Community of Origin ( <i>i</i> )	Community of residence ( <i>j</i> )						
	Punta Aguila	Greytown	Indian River	Rama Cay	Sumu Kat	Bluefields	Zompopera
Punta Aguila	0.2045						
Greytown			0.0135		0.0053	0.0323	
Indian River				0.0053			
Rama Cay	0.4773	0.7297	0.8095	0.9101	0.7903	0.9231	0.7458
Sumu Kat	0.0227			0.0053	0.1290		0.0678
Bluefields	0.1364	0.1622	0.0526	0.0529	0.0323	0.0769	0.0169
Zompopera		0.0135		0.0053			0.1525
<i>Other Rama villag.</i>	<i>0.1136</i>	<i>0.0270</i>		<i>0.0106</i>			
<i>No Rama villag.</i>	<i>0.0455</i>	<i>0.0541</i>	<i>0.0526</i>	<i>0.0053</i>			

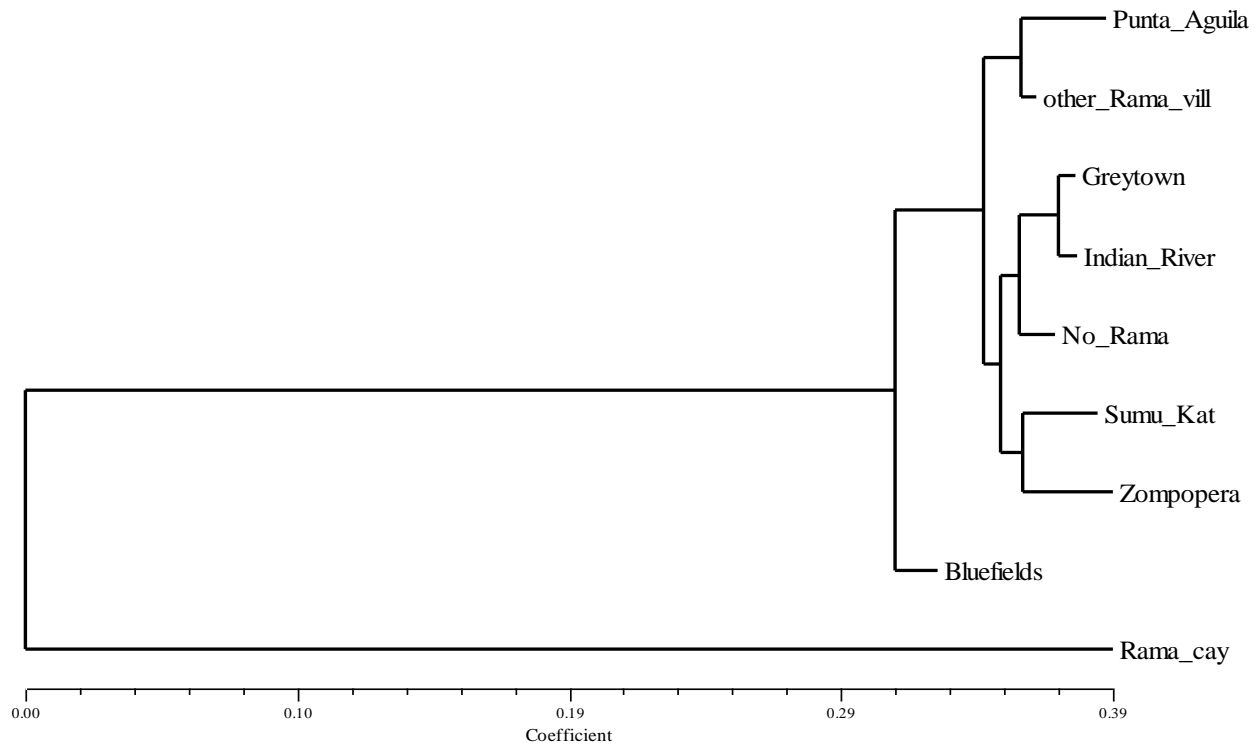

Figure 30. Neighbor Join tree showing internal migration patterns in the Rama territory. All communities have individuals that were born in Rama Cay. Greytown and Indian River have the most individuals born outside the Rama territory, and Punta Aguila has the most individuals born in other Rama communities and less from Rama Cay.

### Exogamic Relationships

Although the Rama kinship system prescribes endogamous marriages, exogamous marriages with Mestizos have been more frequent in the last two generations. Exogamic marriages occurred between Rama and Miskitu and Mayagna (Sumu) two hundred years ago and with Creoles a few decades ago (GTR-K 2007). According to the census carried out between 2005 and 2007 by the regional government, non-Rama partners are integrated into the Rama community as long they follow Rama social norms (GTR-K 2007). Most of the mixed unions

resulting from exogamous relationships are between Rama women and Mestizo men. Table 25 shows that exogamous marriages were more common among Mestizos followed by Miskito and Creole partners in five Rama communities. Most of the Mestizo-Rama unions were recorded in Rama Cay, Greytown, and Sumu Kat. Miskito and Creole partners were more common in Punta Aguila.

Table 25. Exogamic relationships within Rama communities

Community	Mestizo			Miskitu			Creole			Total
	Male	Female	Total	Male	Female	Total	Male	Female	Total	
Rama Cay	9	8	17	8	9	17	5	5	10	<b>44</b>
Zompopera	2	2	4	0	0	0	0	0	0	4
Sumu Kat	5	5	10	0	0	0	0	0	0	10
Punta Aguila	4	4	8	0	2	2	2	2	4	<b>14</b>
Greytown/Indian River	7	7	14	1	1	2	0	0	0	<b>16</b>
Total	22	26	<b>53</b>	9	12	<b>21</b>	7	7	<b>14</b>	88

Source: GTRK 2005-2007.

Based on the network of kinship, 222 links were established between all seven Rama communities. Rama Cay has the most relatives with other communities (values between 0.1 and 1) followed by Sumu Kat and Greytown. In contrast, Punta Aguila, Zompopera, Indian River, and Bluefields have a lower probability (0.01 - 0.5) of having relatives with other communities except with Rama Cay (Table 26). The MDS of these relationships is charted in the figure 31 where upper and lower right communities have less probability to be connected by kinship between each other in comparison to Rama Cay.

Table 26. Probability matrix of kinship network between Rama communities.

Rama Communities	Bluefields	Zompopera	Indian River	Greytown	Sumu Kat	Punta Aguila	Rama Cay
Bluefields	0.0000						
Zompopera	0.0690	0.0000					
Indian River	0.0000	0.0556	0.0000				
Greytown	0.2759	0.1111	0.3571	0.0000			
Sumu kat	0.0000	0.3519	0.5357	0.2364	0.0000		
Punta Aguila	0.0345	0.0185	0.0000	0.0545	0.0345	0.0000	
Rama Cay	0.6207	0.4630	0.1071	0.7091	0.9655	1.0000	0.0000

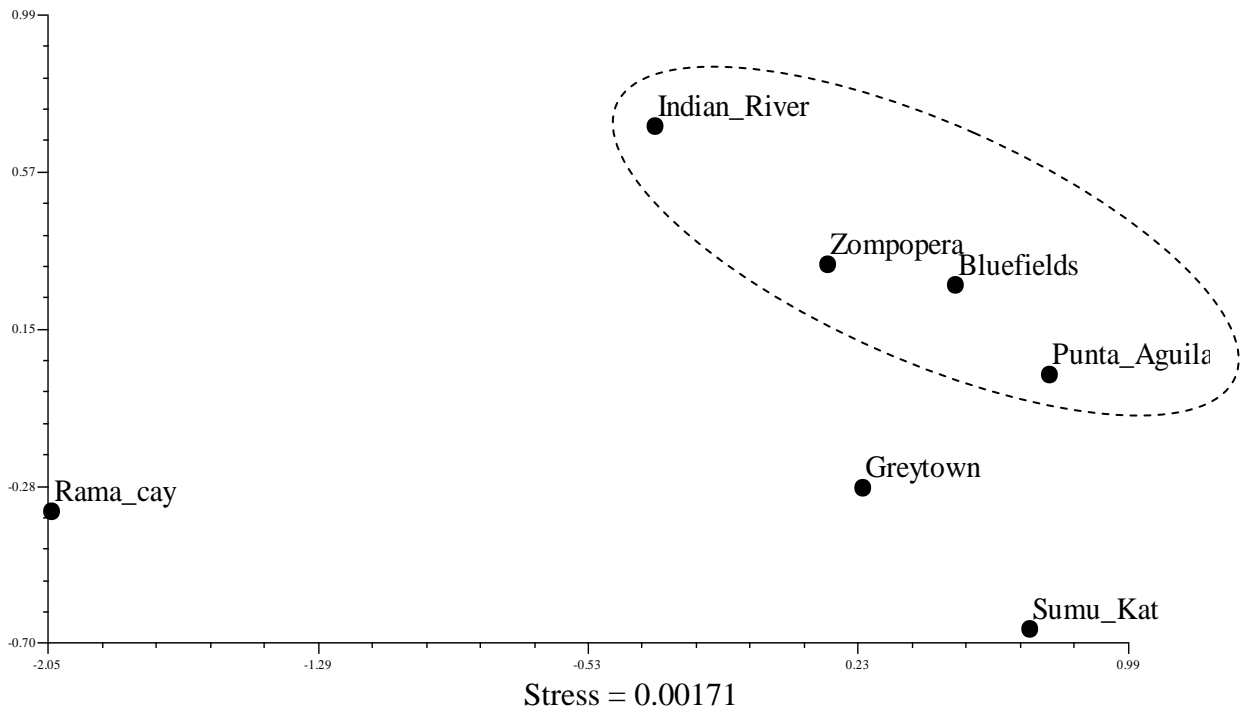

Figure 31. MDS of kinship networks. Upper right shows a group of communities with less probability of sharing relatives between communities. Lower communities (Rama Cay, Greytown, and Sumu Kat) have more links of kinship with other communities.

## Intra Population Variation

Unbiased Isonymy ( $I$ ) approximates the amount of isolation for each community. The highest  $I$  values were found in Bluefields, Indian River, and Sumu Kat. Zompopera is intermediate. These populations have small (Bluefields and Indian River) and medium size (Sumu Kat and Zompopera) samples in comparison to Rama Cay, Punta Aguila, and Greytown which are represented by larger sample sizes (Fig.32).

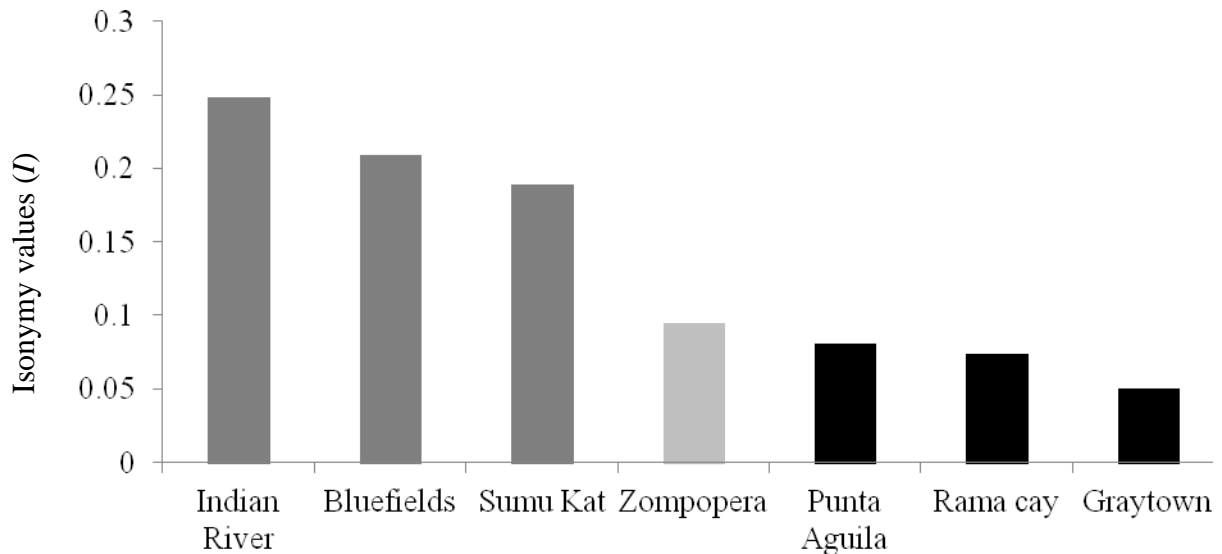

Figure 32. Isonymy values (Y-axis) based on surnames of seven Rama localities (X-axis). Indian River, Bluefields, Sumu Kat, and Zompopera present the highest isolation. Punta Aguila, Rama Cay, and Greytown are the less isolated.

Low isonymy values indicate that mates are more available at Rama Cay, Punta Aguila, and Greytown. Fisher's alpha ( $\alpha$ ) is the parameter that measures surname diversity and the degree of genetic isolation present in a community. Similar to isonymy values, Fisher's alpha

measures genetic isolation and can be used to estimate migration. Populations with higher Fisher's alpha values indicate less isolated communities (more immigration) and include Greytown, Punta Aguila, and Rama Cay. Zompopera has an intermediate value, and Bluefields, Indian River, and Sumu Kat appear to be the most isolated communities (Table 27).

Table 27. Isonymy analysis of 7 Rama localities: The sample size is denoted by N and S is the number of surnames in each community. Unbiased Isonymy is represented by  $I$ . Lasker's coefficient by isonymy is represented by  $R_i$ , and Fisher's Alpha by  $\alpha$ , and  $\Phi_{ii}$  is the kinship coefficient within communities.

Subpopulation	N	S	$I$	$\alpha$	$R_i$	$\Phi_{ii}$
Greytown	136	31	0.05	20	0.028493	0.0125
Rama Cay	204	33	0.073698	13.56880734	0.03912	0.018425
Punta Aguila	62	14	0.08091	12.35947712	0.047867	0.020227
Zompopera	82	18	0.094851	10.54285714	0.052945	0.023713
Sumu Kat	76	19	0.189123	5.287569573	0.099896	0.047281
Bluefields	14	4	0.208791	4.789473684	0.132653	0.052198
Indian River	18	3	0.248366	4.026315789	0.145062	0.062092

### Inter Population Variation

Lasker's coefficient of relationship within populations ( $R_i$ ) is concordant when compared to parameters  $I$ ,  $\alpha$ , and  $\Phi_{ii}$  (Table 27). Table 28 displays a distance matrix indicating significant deviations ( $p < 0.05$ ) between  $R_i$  values from each community. According to these values, Sumu Kat and Indian River are most differentiated from Rama Cay, Punta Aguila and Greytown, while Greytown and Punta Aquila differentiate from Bluefields. Lower values in the matrix imply that the populations are more heterogeneous. Based on Lasker's  $R_{ib}$ , figure 33 shows a cluster of exogamous populations (Greytown, Zompopera, Rama Cay, and Punta Aguila).

Within this group, Greytown is the most admixed population. On the other hand, Bluefields, Sumu Kat, and Indian River are more endogamous communities. This interpretation is also concordant with  $F_r$  and  $RP$  values.

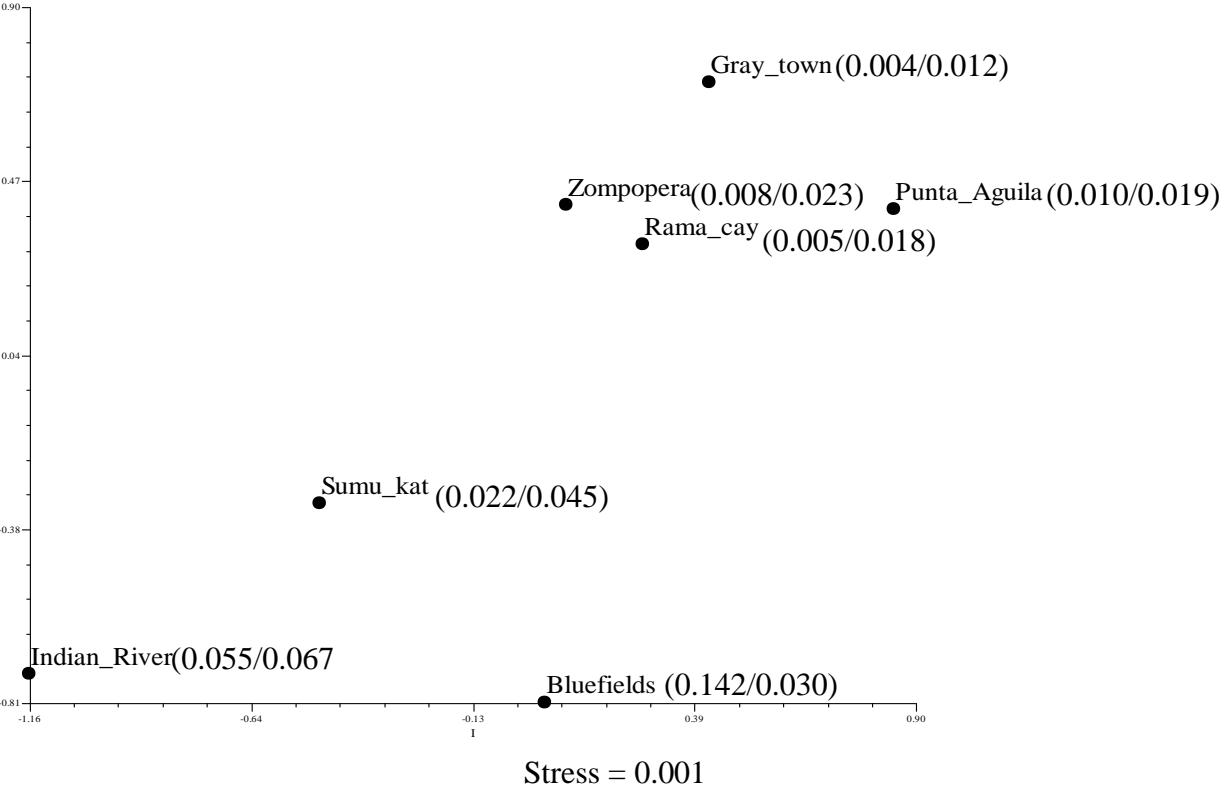

Figure 33. MDS of Lasker’s  $R_{ib}$  values showing two groups. First, exogamous communities cluster in the upper right corner. Second, endogamous populations cluster in the lower left corner.  $RP$  and the  $F_r$  values are listed in parenthesis.

Table 28. Matrix of coefficients of Lasker's relationships by Isonymy ( $R_i$ ). Values in bold are subpopulations (in column) that differentiate the most from other subpopulations (in rows).

Subpopulation	Bluefields	Rama Cay	Greytown	Punta Aguila	Zompopera	Sumu Kat	Indian River
Bluefields	1.0000						
Rama Cay	0.4113	1.00000					
Greytown	<b>0.6272</b>	0.30993	1.0000				
Punta Aguila	<b>0.5345</b>	0.16714	0.1525	1.00000			
Zompopera	0.2618	0.17209	0.4527	0.32763	1.00000		
Sumu Kat	0.1403	<b>0.51586</b>	<b>0.6971</b>	<b>0.62025</b>	0.38477	1.00000	
Indian River	0.2148	<b>0.56649</b>	<b>0.7299</b>	<b>0.66098</b>	0.44607	0.07738	1.00000

Significant deviations in bold ( $p < 0.05$ ).

Table 29. Matrix of Lasker's coefficient of relationship between communities ( $R_{ib}$ ). The highest correlations between communities are shown in bold.

Subpopulation	Bluefields	Rama Cay	Greytown	Punta Aguila	Zompopera	Sumu Kat	Indian River
Bluefields	1.0000						
Rama Cay	0.0399	1.0000					
Greytown	<b>0.0794</b>	<b>0.0519</b>	1.0000				
Punta Aguila	<b>0.0541</b>	0.0216	0.0394	1.0000			
Zompopera	<b>0.0537</b>	0.0266	<b>0.0547</b>	0.0317	1.00000		
Sumu Kat	<b>0.0865</b>	0.0405	<b>0.098</b>	0.0416	<b>0.05044</b>	1.00000	
Indian River	<b>0.0575</b>	0.0258	<b>0.0528</b>	0.0242	0.03464	<b>0.05608</b>	1.00000

Another pattern illustrated by Lasker's coefficient of relationships between communities ( $R_{ib}$ ) (Table 29) is that most communities are correlated at least once with other communities. For example, Rama Cay correlates with Greytown, and Greytown correlates with four other communities (Sumu Kat, Indian River, Zompopera, and Bluefields). Punta Aguila is isolated and only correlates with Bluefields. Based on these correlations, Punta Aguila has fewer surnames affinity with the other six Rama communities (Fig.34).



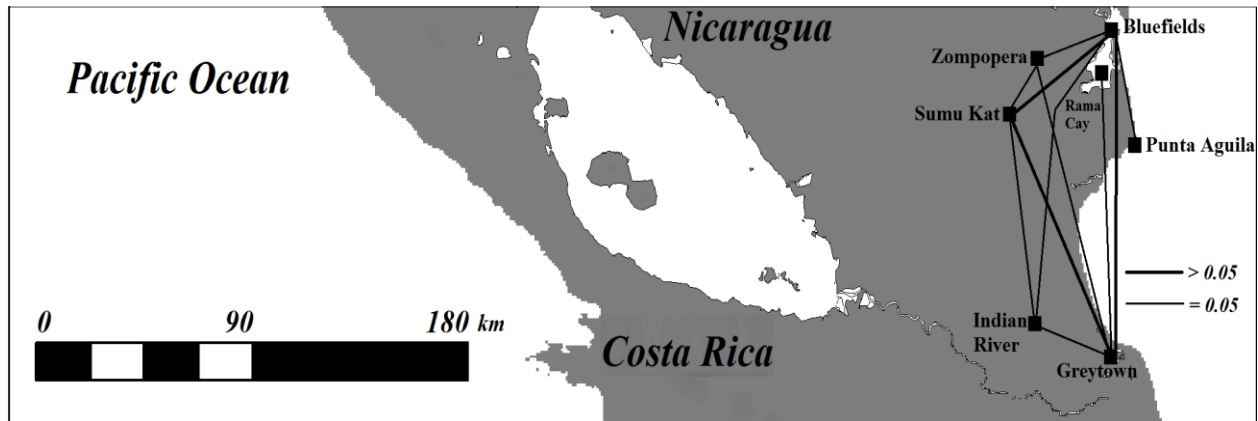

Figure 34. Map of Lasker's coefficient of relationships ( $R_{ib}$ ) showing major surname associations between communities.

The coefficient of kinship ( $\Phi_{ij}$ ) measures loss of heterozygosity between populations as a function of geographic distance (Relethford 1988). The MDS plot (Fig.35) shows the separation of more heterozygous communities as outliers in the plot (Rama Cay, Punta Aguila, and Greytown) and less heterozygous closer together (Zompopera and Indian River, and Bluefields and Sumu Kat). The MDS (Fig.36) uses the unbiased random isonymy matrix ( $I_{ij}$ ) to produce similar results: populations with the greatest amount of heterozygosity, such as Rama Cay, Punta Aguila, and Greytown are outliers in the plot. More isolated populations are closer to the centroid (Indian River, Bluefields, Zompopera, and Sumu Kat). Isonymy values are included in parenthesis and show concordant associations with the coefficients of kinship.

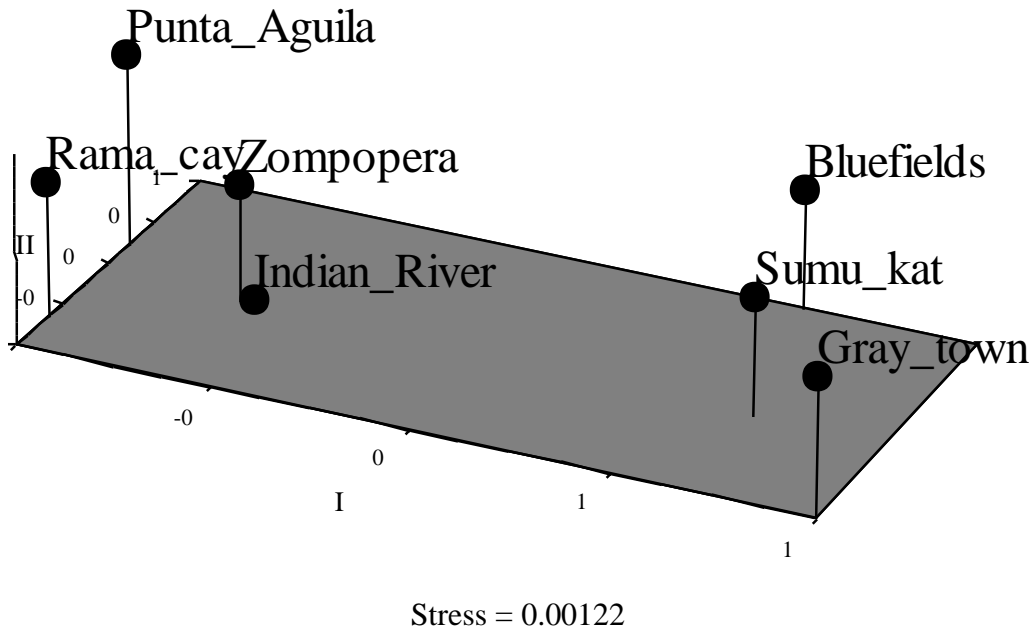

Figure 35. MDS of *a-priori* kinship between Rama subpopulations ( $\Phi_{ij}$ ).

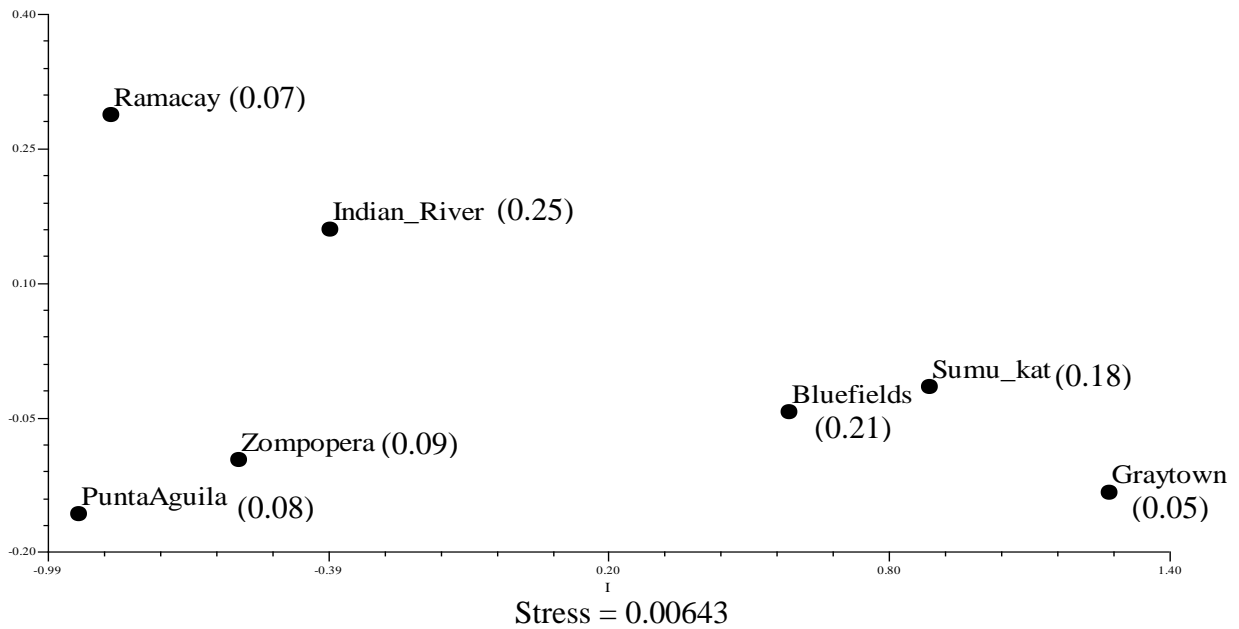

Figure 36. MDS coefficient of kinship between subpopulations ( $I_{ij}$ ) and unbiased Isonymy values in parenthesis ( $I_{ij}$ ).

## **Biodemographic Structure**

Inbreeding levels for Rama Amerindians derived from surname transmission were estimated by the indexes of the subdivided populations and have three components: the correlation of uniting surnames relative to the whole population  $F_t$  ( $F_{it}$ ), the correlation between randomly selected surnames relative over all subpopulations described by  $F_n$  ( $F_{is}$ ), and the correlation between randomly selected surnames relative to the whole population denoted by  $F_r$  ( $F_{st}$ ). Combined, these  $F$ -statistics measure the effects of non-random mating on populations of finite size (Crawford 2001). The values obtained from this analysis are summarized in table 30. Zompopera and Sumu Kat have the highest value of the total consanguinity ( $F_t$ ), and Punta Aguila and Rama Cay are intermediate compared to Greytown, Bluefields, and Indian River, which are the lowest. The last three populations have negative values indicating outbreeding, or excess of heterozygotes. The random component of inbreeding ( $F_r$ ), equivalent to  $F_{st}$ , and informative of genetic drift is higher for the smallest and most isolated populations such as Sumu Kat, Indian River, Bluefields, and Zompopera. On the other hand, Punta Aguila, Rama Cay, and Greytown are less influenced by drift. The non-random component ( $F_n$ ) indicates that all populations except for Zompopera show aversion towards unions between consanguineous mates. In Zompopera, the surnames Blayat, Ruiz, and Macrea account for 51% of a sample of 82 individuals and has the highest rates of individuals who were born and stayed in the community.

Table 30. Values of total ( $F_t$ ), non-random ( $F_n$ ), and random ( $F_r$ ) consanguinity; and repeated ( $RP$ ) and random repeated pairs ( $RP_r$ ) values based on isonymy for seven Rama communities.

Subpopulation	$F_t$ ( $F_{it}$ )	$F_r$ ( $F_{st}$ )	$F_n$ ( $F_{is}$ )	$RP$	$RP_r$	% difference
Greytown	-0.00049	0.012435	-0.01309	0.004829	0.002501	0.930806
Bluefields	-0.0032	0.030612	-0.03488	0.142857	0.095238	0.5
Indian River	-0.01899	0.067901	-0.09322	0.055556	0.042438	0.309091
Punta Aguila	0.007311	0.019771	-0.01271	0.010753	0.005272	1.039474
Rama Cay	0.009278	0.018551	-0.00945	0.005048	0.005342	-0.05506
Sumu Kat	0.023236	0.045014	-0.0228	0.02276	0.032687	-0.3037
Zompopera	0.044174	0.023647	0.021025	0.008537	0.008043	0.061391

The repeated pair approach was used to estimate the degree of subdivision of the population into subgroups that breed among themselves. If two populations have different allele frequencies, the overall heterozygosity is reduced causing population subdivisions or population substructure. These subdivisions can result from a variety of causes including geographic barriers to gene flow (genetic drift) and/or other cultural associated behaviors of preferential mating systems. The resulting impact on gene frequencies is known as the Wahlund effect or the reduction of heterozygosity in a population caused by subpopulation structure (Koertvelyessy et al. 1988). This is evaluated by the deviation of the non-random component ( $RP$ ), that depicts the exchange of brides, from a randomly expected  $RP_r$  component (Lasker and Kaplan 1985). In the context of this analysis, high inbreeding is not the resulting preference for consanguineous marriages between individuals but the effect of having few available mates with the same surnames.

Table 30 and figure 37 illustrates data from the repeated pair approach. The highest proportions of surname repeats ( $RP$ ) are found in Bluefields, Indian River, and Sumu Kat while the lowest  $RP$  values are found in Greytown, Rama Cay, Punta Aguila, and Zompopera. Ratios of  $RP$  on  $RP_r$  were calculated as a percentage and they show population substructure in decremental order of subdivision: Punta Aguila, Greytown, Bluefields, Indian River, and Zompopera. Of these populations, Punta Aguila and Greytown have the highest degree of subdivision or population substructure. On the other hand, Rama Cay and Sumu Kat have an excess in the random  $RP_r$  component meaning that they have less internal substructure or intergroup subdivisions.

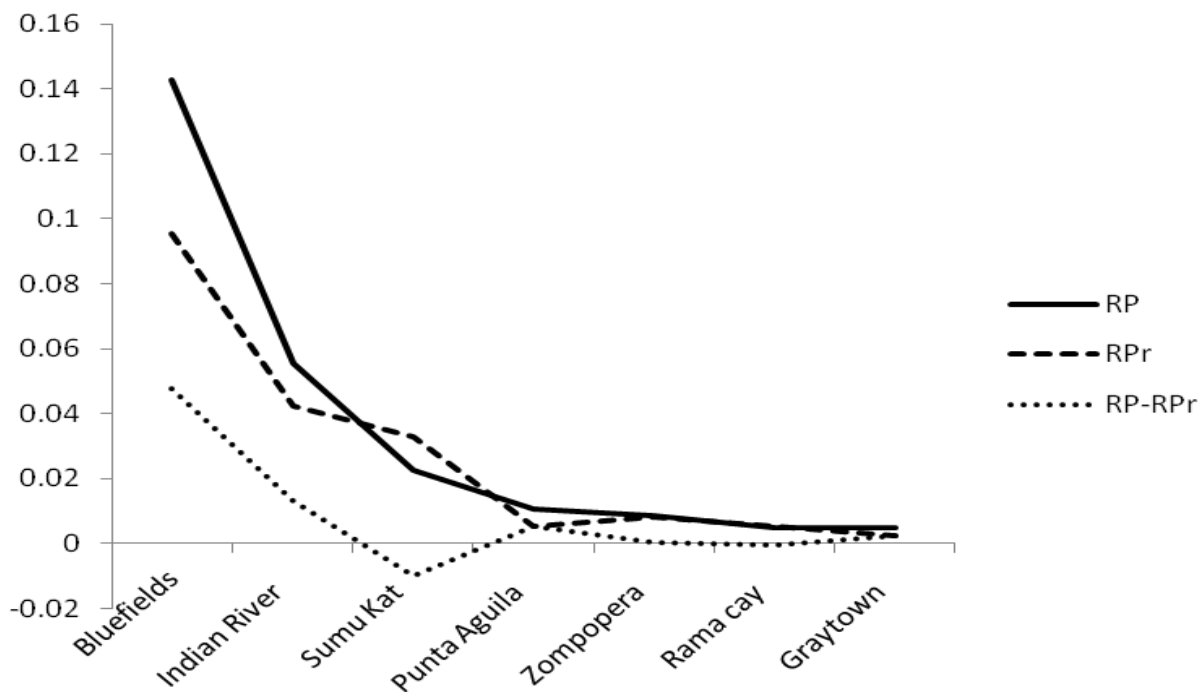

Figure 37. Trends in  $RP$ ,  $RP_r$ , and  $RP-RPr$  values. Bluefields, Indian River, and Sumu Kat are the most isolated populations with less internal subdivisions. Punta Aguila and Greytown have the highest degree of internal subdivisions.

## Isolation by Distance

Isolation by distance was evaluated by correlating the geographic distances of the seven Rama villages as well as by using surname distance models such as Lasker's distances (Lasker's  $D$ ), Euclidian distances ( $\theta$ ), and Lasker's coefficient of relationship ( $R_{ib}$ ). Euclidian distances and linear geographic distances are significantly and positively correlated ( $r = 0.42$ ,  $p = 0.03$ ), Lasker's  $D$  and geographic distances have a significant positive correlation ( $r = 0.43$ ,  $p = 0.05$ ), and the relationship of Euclidian distances and Lasker's coefficient of relationship between communities ( $R_{ib}$ ), is weakly correlated ( $r = 0.26$ ,  $p = 0.04$ ). This means that kinship decreases exponentially with distance as is predicted by Malecot's isolation by distance model (Dipierri et al. 2005).

$R_{ib}$  and geographic distance are not correlated ( $r = 0.26$ ,  $p = 0.08$ ). Additional matrices were at the limit of its significance. The other matrices including Lasker's  $D$  with Euclidian distances, and Lasker's  $D$  with Lasker's  $R_{ib}$  resulted in negative associations (Table 31).

Table 31. Mantel correlations between distance matrices and Lasker's  $R_{ib}$  coefficients. Significant  $p$ -values ( $p < 0.05$ ) are in bold and above the diagonal while  $r$  values are listed below the diagonal.

Matrix	Geography	Lasker 's $D$	Euclidian $\theta$	Lasker's $R_{ib}$
Geography	1	<b>0.05</b>	<b>0.03</b>	0.08
Lasker's $D$	0.43	1	0.55	0.54
Euclidian	0.42	-0.02	1	<b>0.04</b>
$R_{ib}$	0.26	-0.05	0.43	1

The MDS map of distances between Rama communities is depicted on figure 38. Geographically, Rama Cay is located in the Bay of Bluefields 14 Km away from the Punta Fria

neighborhood in Bluefields where some Rama lives. Zompopera is located between Rama Cay and Sumu Kat. These two communities are inland and can only be accessed by river. Punta Aguila is a coastal community between Rama Cay and Greytown and is geographically close to Monkey Point, a Creole community.

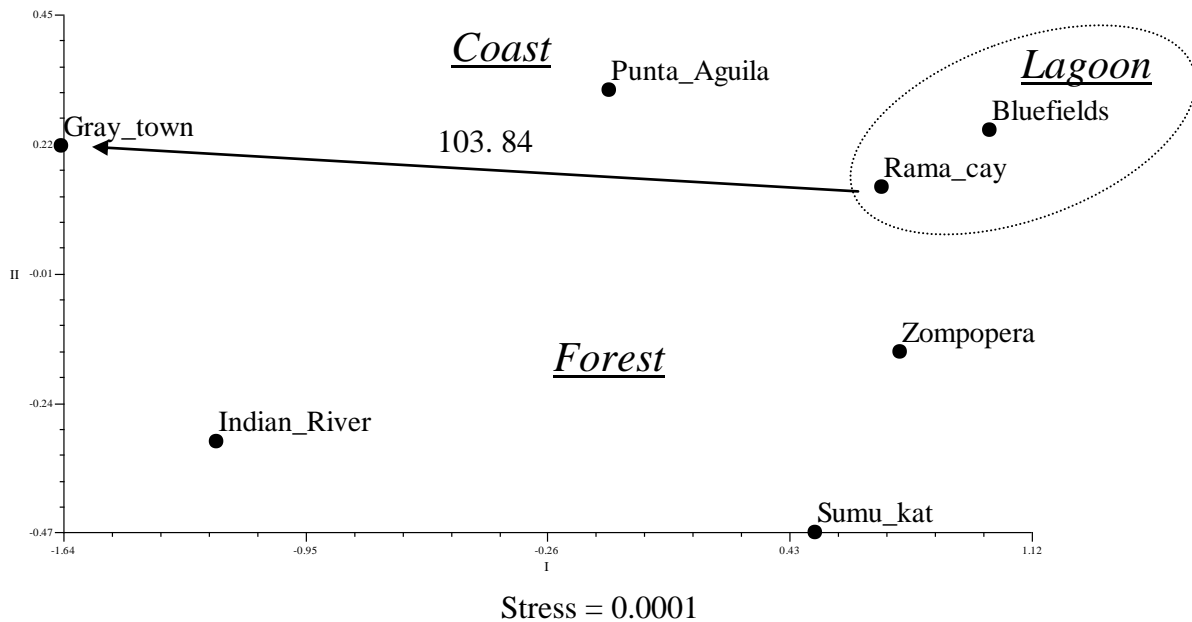

Figure 38. Map of the geographical positions generated by MDS (in Km) of seven Rama communities. Bluefields and Rama Cay are located in the Bay of Bluefields. Zompopera, Sumu Kat, and Indian River are situated inland. Punta Aguila is a coastal population, and Greytown is located in the mouth of the San Juan River delta.

Lasker’s *D* depicts the geographic relationships, based on surname distances, between seven Rama communities in multidimensional space. According with the diagram 39, a cluster of populations including Bluefields, Sumu Kat, and Zompopera share more surname similarities. The second cluster includes Rama Cay and Indian River. These two populations are a hundred

kilometers away and do not fit the model. Punta Aguila and Greytown are outliers and are geographically distant from any other populations.

Euclidian distances shown in two-dimensional MDS space show similar results as Lasker's  $D$ , and are consistent with geographic distances between communities shown in figure 40.

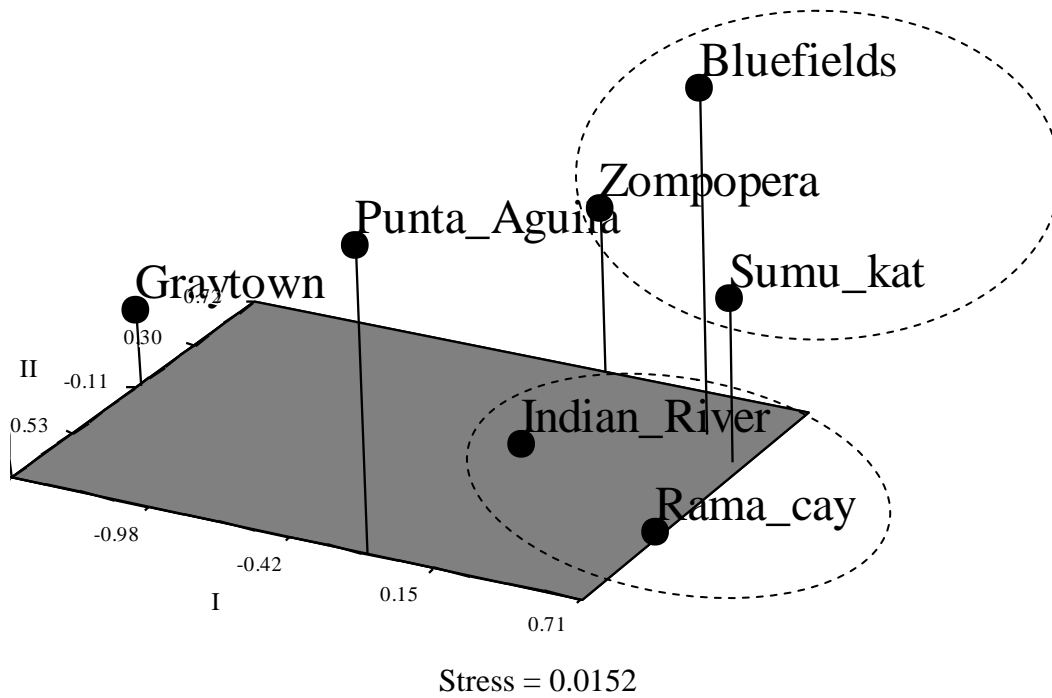

Figure 39. 3-D MDS of Lasker's  $D$  showing kinship relationships based on isonymy between populations.



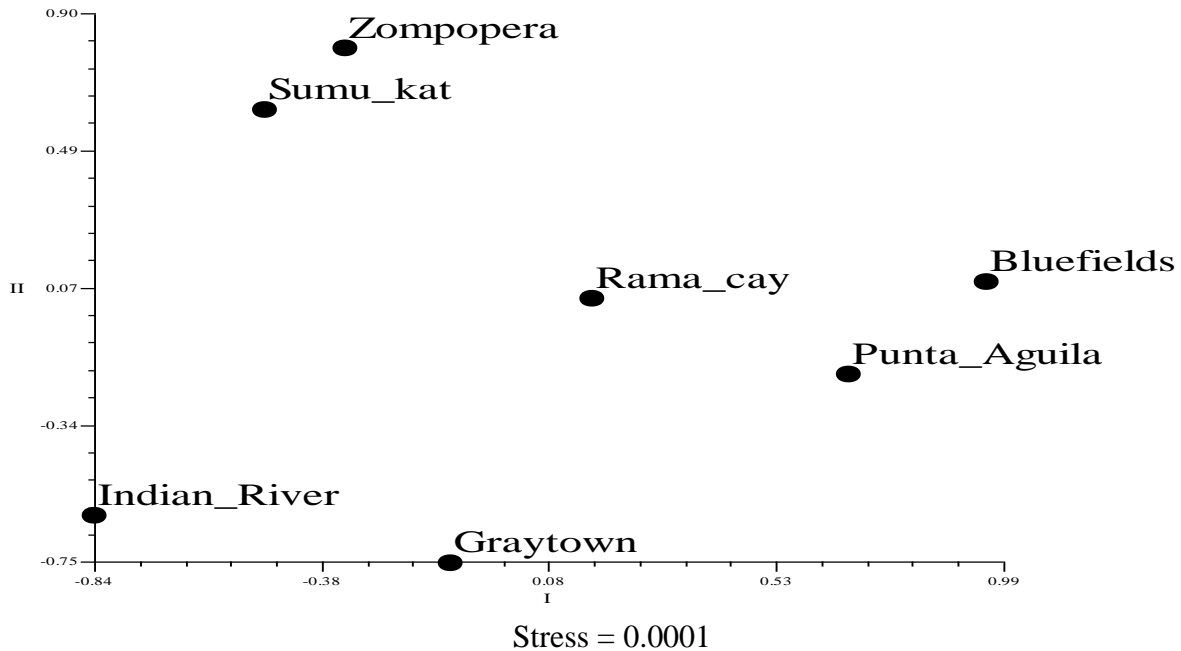

Figure 40. MDS of Euclidian distances between Rama communities.

### ***GENETIC STRUCTURE OF THE RAMA***

This section reports the testing and characterization of population structure among the Rama Amerindians. Analyses include restriction fragment polymorphisms (RFLPs) for haplogroup assignation, mtDNA HVS-I genetic sequencing results, measures of selective neutrality (Fu's  $F_s$ , Tajima's  $D$ ), diversity values (genetic diversity [ $H$ ], number of variant sites [ $\theta_s$ ], nucleotide diversity [ $\theta_\pi$ ]), and mismatch distributions. For interpopulation analysis, median joining, MDS plots,  $R$ -matrix, Monmonier's algorithm, and AMOVA were performed.

### **Restriction Fragment Length Polymorphisms (RFLPs) and Haplogroup Characterization**

The RFLP analysis reveals the presence of three haplogroups (A2, B2, and C1) of the major macro-haplogroups present in America (A, B, C, D) (Schurr et al. 1990; Wallace and

Torrioni 1992; Zhang 1998) in the Rama Amerindian sample. Of the total haplogroups, 71% belong to B2 and were assigned by the presence of the +8250 *Hae III* marker that identifies the 9bp deletion (-CCCCCTCTA-) at COII-tRNA<sup>lys</sup>, and were cross checked using their genealogical correspondence. Haplogroup A2, assigned by the presence of +*HaeIII* at np 663, accounted for 28% of the total sample. One individual was classified as C1 based on the lack (-) of the cut site *HincIII* at site 663 and the presence (+) of *AluI* at site 13262. This individual was further assigned as C1b based on the most up to date mtDNA phylogeny and nomenclature: [phylotree.org](http://phylotree.org) (van Oven and Kayser 2009). An additional sample did not correspond with any of the four major Native American haplogroups. Typed to the African lineage L3, it is a signature of recent genetic admixture. This lineage was assigned through sequencing of the HVS-I and [phylotree.org](http://phylotree.org). A future examination of additional mutational motifs in the HVS-II segment of the mtDNA will confirm the presence of the C1b haplogroup through the transition at np 493G, and 522-523d (Achilli et al. 2008; Ebenesersdóttir et al. 2011).

Within Rama subpopulations B2 is most frequent among Sumu Kat, Rama Cay, Bluefields, Greytown, and Indian River. Sub-haplogroup A2 is more frequent in Punta Aguila while A2 and B2 are equally represented in Zompopera. C1 and L3 lineages appear in Greytown close to the San Juan River between Costa Rica and Nicaragua (Table 32).

Table 32. Percentages of haplogroups among Rama subpopulations.

Community	Haplogroups (%)				Total individuals
	A2	B2	C1	L3	
Sumu kat	10	90			31
Rama Cay	21	79			111
Bluefields	0	100			7
Punta Aguila	59	41			22
Greytown	26	70	2	2	46
Indian River	40	60			10
Zompopera	50	50			38
% total	28	71	<1	<1	265

Table 33 shows the haplogroup proportions of 32 indigenous populations from Mesoamerica, Central America, the Caribbean, and northern South America. In comparison with these populations the Rama Amerindians exhibit a greater frequency of subhaplogroup B2 and less frequency of A2 than other Chibchan speakers from Central and South America. A previous study found the same pattern but in different proportions (A2: 8% and B2: 92%) (Melton 2008). Contrary to this pattern, Mesoamerican populations (Mayans, Oto-Mangueans, Uto-Aztecan, and Tarascan) show higher frequencies of A2 (> 40%) as do Chibchan speakers from Central America (> 60%). Haplogroup B2 is less common among these linguistic aggregates (< 30%). In northern South America, haplogroup B2 is present in variable percentages among Arawak, Chocoan, Barbacoans, and Yanomam speakers (> 5% and < 60%) but is almost absent among Chibchan speakers (< 3%) and is absent in extinct Caribbean populations (Ciboney and Taino) from Cuba and Dominican Republic.

Haplogroup D1 is found among Mesoamerican populations (< 20%) and in the Chibchan speaking Huetar and the Uto-Aztecan speaking Chorotega from Costa Rica (~ 15%). D1 is also present in low and moderate proportions among the Tucanoan, Yanomam, Barbacoan speakers, and Taino and Ciboney but absent in the majority of Chibchans speakers from SCA and Colombia as well as the Rama.

The haplogroup C1 is divided in five subclades (C1b, C1c, C1d, C4c, and C1e) (Achilli et al. 2008; Ebenesersdóttir et al. 2011; Tamm et al. 2007) through the Americas. C1 occurs in various frequencies among Mesoamerican populations (< 30%) as well as in Chibchan speakers from Colombia (< 45%). Contrary to the previous suggestion by Kolman and Bermingham (1997) of the absence of the haplogroup C1 and D1 through their genetic history of the Central American Chibchan, recent research by Perego et al.(2012) has reported low frequencies of the subclades C1d and C1c among the Chibchan Ngöbé-Buglé (3.7%) and Kuna-Yala (8.3%) in the Caribbean side of Panama, as well as the possible haplogroup C1b in the present study. In a recent genetic survey across Nicaragua, haplogroup C1 was absent and haplogroup D1 was present in a very low frequency (1.22%) (Nuñez et al. 2010).

Table 33. Native American haplogroup frequencies of 33 comparative populations

Population	N	Haplogroup (%)					Linguistic affiliation*	Reference
		A	B	C	D	Other		
<b>Mesoamerica*</b>								
Otomi	68	40	25	29	6	0	Oto-Manguean	(Sandoval et al. 2009)
Triqui	107	72	28	0	0	0	Oto-Manguean	(Sandoval et al. 2009)
Mixtec	19	79	11	5	5	0	Oto-Manguean	(Sandoval et al. 2009)
Xochimilco	35	77	14	9	0	0	Uto-Aztecan	(Sandoval et al. 2009)
Ixhuatlancillo	10	40	10	30	20	0	Uto-Aztecan	(Sandoval et al. 2009)
Zitlala	14	100	0	0	0	0	Uto-Aztecan	(Sandoval et al. 2009)
Necoxtla	25	48	52	0	0	0	Uto-Aztecan	(Sandoval et al. 2009)
Yucatec	52	62	17	15	6	0	Maya	(Sandoval et al. 2009)
Poqomchi'	65	82	6	12	0	0	Maya	(Justice 2011)
Ch'orti'	57	70	0	25	0	5	Maya	(Justice 2011)
Maya	25	72	20	4	4	0	Maya	(Healy and Hunley 2008)
K'iche' S. Cruz	23	70	26	4	0	0	Maya	(Boles et al. 1995)
Purepecha	34	59	9	24	9	0	Tarascan	(Sandoval et al. 2009)
<b>Central America</b>								
<b>Rama</b>	<b>265</b>	<b>28</b>	<b>71</b>	<b>&lt;1</b>	<b>0</b>	<b>&lt;1</b>	<b>Chibchan (Votic)</b>	<b>This study</b>
Maleku—Guatuso—	35	91	9	0	0	0	Chibchan (Votic)	(Melton 2008)
Huetar (pool)	67	64	16	0	15	4	Chibchan (Votic)	(Melton 2008; Santos et al. 1994)
Ngöbé	77	64	36	0	0	0	Chibchan (Isthmic)	(Kolman et al. 1995)
Guaymí—Abrojo—	50	78	22	0	0	0	Chibchan (Isthmic)	(Melton 2008)
Kuna	63	71	29	0	0	0	Chibchan (Isthmic)	(Batista et al. 1995)
Chorotega—Matambu—	30	73	10	0	17	0	Oto-Manguean	(Melton 2008)
Wounan	57	32	37	26	5	0	Chocoan	(Kolman and Bermingham 1997)
<b>Northern South America</b>								
Arsario	47	64	0	36	0	0	Chibchan (Magdalenic)	(Melton et al. 2007)
Ijka	31	90	3	6	0	0	Chibchan (Magdalenic)	(Melton et al. 2007)
Kogi	48	56	0	44	0	0	Chibchan (Magdalenic)	(Melton et al. 2007)
Emberá	44	23	52	25	0	0	Chocoan	(Kolman and Bermingham 1997)
Wayuu	42	38	26	36	0	0	Arawak	(Melton et al. 2007)
Coreguaje	27	4	19	66	11	0	Tucanoan	(Tamm et al. 2007)
Vaupés	22	23	14	36	27	0	Tucanoan	(Tamm et al. 2007)
Yanomamo	129	2	7	50	34	7	Yanomam	(Merriwether et al. 2000)

Population	N	Haplogroup (%)					Linguistic affiliation	
		A	B	C	D	Other		
<b>Northern South America (cont.)</b>								
Shamatari	155	0	56	32	12	0	Yanomam	(Williams et al. 2002)
Cayapa	30	30	40	10	20	0	Barbacoan	(Rickards et al. 1999)
<b>Caribbean</b>								
Taino	24	0	0	75	25	0	Arawak	(Lalueza-Fox et al. 2001)
Ciboney	15	7	0	60	33	0	Arawak	(Lalueza-Fox et al. 2003)

(\*) (Constenla 1991; Lewis 2009)

### HVS-I Sequencing

A total number of two hundred and six individuals were sequenced for HVS-I region. Individual sequences and counts are shown in table 34. From this, a subsample of 131 (Sumu Kat: 15, Punta Aguila: 21, Indian River: 10, Greytown: 43, Zompopera: 37, and Rama Cay: 80) of individuals no immediately related (e.g., excluding siblings, parents) was chosen for interregional genetic comparison.

In this investigation, nine new haplotypes for the Rama (**CA19**, **CA20**, **CA23**, **CA24**, **CA25**, **CA26**, and **CA27**) are added to the eight haplotypes (**CA1**, **CA2**, **CA4**, **CA5**, **CA8**, **CA9**, **CA10**, **CA11**) previously reported by Melton's (2008) investigation . Haplotype **CA8** is the most frequent (117 ind.) among all Rama subpopulations and corresponds with the founding Amerindian lineage B2 common through the Americas and in SCA and characterized by the T-C transition at position 16217 (Achilli et al. 2008).

The second most frequent lineage among the Rama is the haplotype **CA4** that is shared by 45 individuals from all communities. This haplotype is associated with the founding haplogroup A2 and is also present among the Guaymí from Costa Rica. The third most

common haplotype is **CA5** which corresponds to haplogroup A2 and is more frequent in Punta Aguila (9 ind.). This haplotype is characterized by a T-C transition at nucleotide position 16189. CA5 was previously reported among the Chorotega from Costa Rica and the South American Chibchan speakers, Kogi and Arsario (Melton 2008; Melton et al. 2007). Two individuals from Rama Cay and Punta Aguila share the haplotype **CA1** that is present among the Guatuso and Guaymí from Costa Rica as well as the Maya from Central America (Justice 2011; Melton 2008).

Haplotypes **CA2** and **CA22** correspond to the haplogroup A2, and the haplotypes **CA9**, **CA19**, **CA20**, **CA10**, and **CA25** (hapl. B2) were present only in Rama Cay while haplotype **CA11** is shared between Rama Cay and Sumu Kat. **CA21** is shared between Zompopera, Punta Aguila and Greytown and haplotypes **CA23** and **CA24** are present in Punta Aguila and Greytown respectively.

Table 34. mtDNA sequences for six Rama subpopulations. Only variable sites are shown.

Haplogroup	Haplotypes	16108	16111	16172	16174	16187	16189	16192	16217	16218	16223	16242	16250	16256	16258	16269	16270	16290	16291	16298	16311	16319	16325	16327	16334	16349	16360	16362	Total
CRS		C	C	T	C	C	T	C	C	C	C	C	C	C	A	T	C	C	C	T	T	G	T	C	T	A	C	T	
A2	CA4	.	T	.	.	T	.	.	.	.	T	.	.	.	.	.	.	T	.	.	.	A	.	.	.	.	.	C	10
	CA5	.	T	.	.	T	.	.	.	.	T	.	.	.	.	.	.	T	.	.	.	A	.	.	.	.	.	C	45
	CA21	.	T	.	.	T	.	.	.	.	T	.	.	.	C	.	.	.	.	.	.	A	.	.	.	.	.	C	16
	CA22	.	T	.	.	T	.	.	.	.	T	.	.	.	C	.	.	T	.	.	.	A	.	.	.	.	.	C	3
	CA1	.	T	.	.	T	.	.	.	.	T	.	.	.	C	.	.	T	.	.	.	A	.	.	.	.	.	C	1
	CA2	.	T	.	.	T	.	.	.	.	T	.	.	.	C	.	.	T	.	.	.	A	.	.	.	.	.	C	2
		.	T	.	.	T	.	.	.	.	T	.	.	.	C	.	.	T	.	.	.	A	.	.	.	.	.	C	1
B2	CA8	.	.	.	.	.	.	.	.	.	.	.	.	.	.	.	.	.	.	.	.	.	.	.	.	.	.	.	47
	CA19	A	.	.	.	.	.	.	.	.	.	.	.	.	.	.	.	.	.	.	.	.	.	.	.	.	.	.	5
	CA20	.	.	.	.	.	.	.	.	.	.	.	.	.	.	.	.	.	.	.	.	.	.	.	.	C	.	.	2
	CA9	.	.	.	.	.	.	.	.	.	.	.	.	.	.	.	.	.	.	T	.	.	.	.	.	.	.	.	2
	CA10	.	.	.	.	.	.	.	.	.	.	T	.	.	.	.	.	.	.	T	.	.	.	.	.	.	.	.	1
	CA11	.	.	.	.	.	.	.	.	.	.	T	.	.	.	.	.	.	.	.	.	.	.	.	.	.	.	.	2
	CA23	.	.	.	.	.	.	.	.	.	.	.	.	.	.	C	.	.	.	.	.	.	.	.	C	.	.	.	0
	CA24	.	.	.	.	.	.	.	.	.	.	.	T	.	.	.	.	.	.	.	.	.	.	.	.	.	.	.	0
	CA25	.	.	.	.	.	.	.	.	.	.	.	.	.	.	.	A	.	.	.	.	.	.	.	.	.	.	.	2
C1	CA26	.	C	.	.	.	.	.	.	.	T	.	.	.	.	.	.	.	.	.	.	.	.	.	.	.	.	.	0
L3	CA27	.	C	T	.	.	.	.	.	.	T	.	.	.	A	.	.	.	.	.	.	C	.	.	.	.	.	.	0



One individual was preliminary assigned as belonging the haplogroup C1b (Achilli et al. 2008; Kumar et al. 2011; Perego et al. 2009; Tamm et al. 2007). This individual was found in Greytown and contains the mutational motifs C16223T, T16298C, T16111C, T16325C, and C16327T and an additional mutation (C-T) at np16172. Haplogroup C1b is common in northern South America and in ancient Tainos and Ciboneys from Cuba and the Dominican Republic (Lalueza-Fox et al. 2003; Lalueza-Fox et al. 2001; Merriwether et al. 2000; Williams et al. 2002).

The African haplotype **CA23**, corresponding with haplogroup L3, was also reported at Greytown and is the only genetic signature of maternal gene flow among the Rama Amerindians.

### **Haplotype Network and Chronometry**

In order to compare the sequence haplotype variation between six Rama subpopulations (Punta Aguila, Zompopera, Rama Cay, Greytown, Indian River, and Sumu Kat) a reduced median joining network was constructed from mtDNA HVS-I variable mutations (Fig.41). A single network includes haplogroups: A2, B2, C1, and L3 and provides the graphical representation of the 17 haplotypes that were characterized in the previous section (16 of Native American origin). Each circle is filled with different colors representing the frequency of each Rama subpopulation. Haplogroup A2 has two main nodes or haplotypes (CA1, CA2, CA4, CA4, CA21 and CA22). Haplotype CA1, in the center, is the oldest of five surrounding A2 haplotypes found only in Rama Cay and Punta Aguila. In contrast, CA4 is more frequent in Zompopera, Rama Cay, and Greytown, and less frequent in Sumu Kat, Indian River, and Punta Aguila. CA5

is more numerous in Punta Aguila in comparison to Rama Cay, Indian River and Zompopera. The low frequency of CA1 among the Guatuso, the Guaymí from Costa Rica and the Maya from Central America, might have resulted from genetic drift after the fission of populations inhabiting Central America (Mayas and Chibchans) and subsequent expansion or gain of mutations at np 16187, 16189, and 16360. Two other haplotypes (CA21 and CA22) are only present among the Rama and are not shared with any other populations reported in the comparative data of Central America.

The most frequent haplotype of haplogroup B2 is CA8. This haplotype is shared among other Central American populations (Kuna, Emberá, Zapaton-Huetar, Guatuso\_Maleku, Guaymí, Chorotega) and it reaches its high frequency at Rama Cay, Greytown, and Zompopera. CA8 is less frequent in Sumu Kat, Indian River, and Punta Aguila. The star-like shape of this founder haplotype and associated nodes is indicative of population explosion and gain of genetic diversity. Satellite node CA23, present in Punta Aguila, is separated from CA8 by a hypothetical ancestral node between np 16269 and 16223.

Haplotype CA26 corresponds to haplogroup C1 and haplotype CA27 to the African haplogroup L3. Both haplotypes were found in Greytown in southern Nicaragua close to the San Juan River.

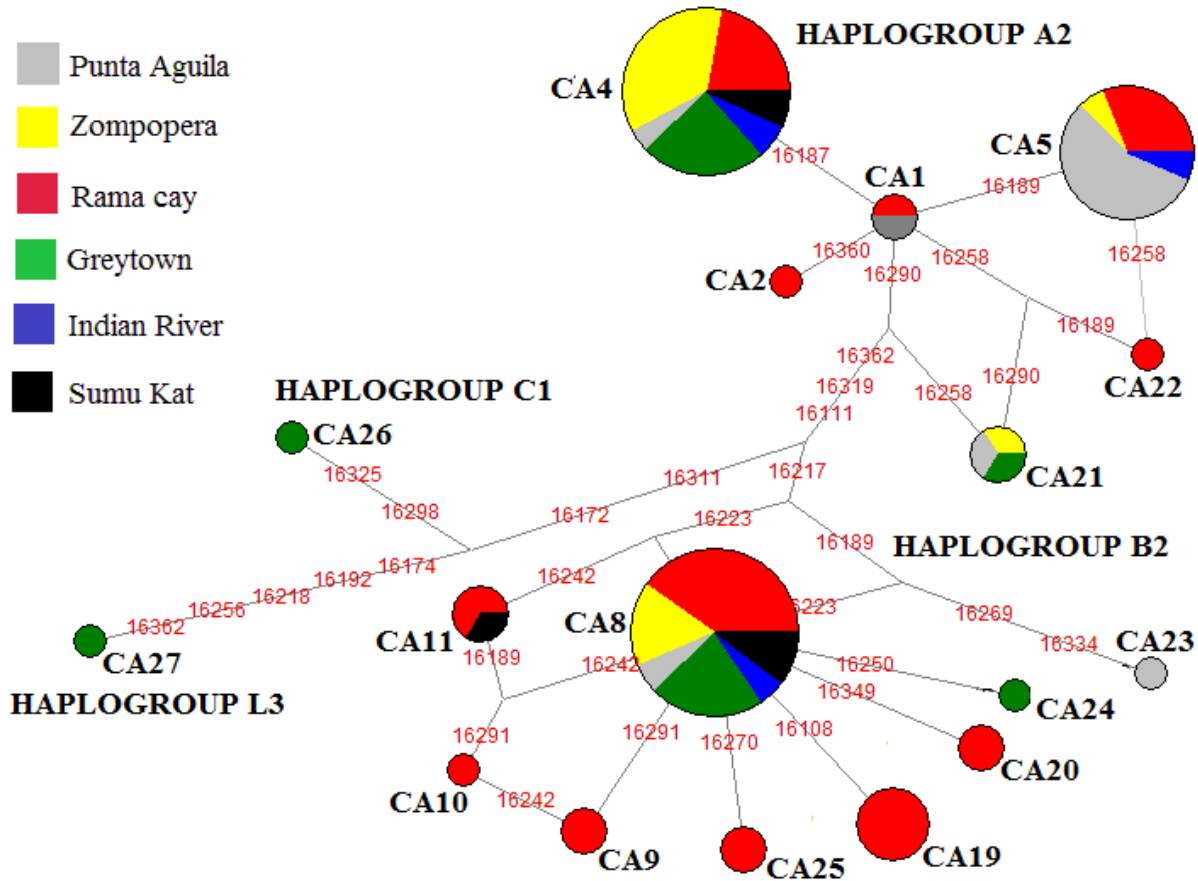

Figure 41. Median joining phylogenetic network of mtDNA sequence of six Rama subpopulations.

In order to estimate coalescence time of the associated haplotypes of both haplogroups A2 and B2, the rho statistic ( $\rho$ ) was calculated from the constructed phylogeny shown in the figure 41. This statistic represents the average number of mutations between the root haplotypes CA1 and CA8 and descendent satellite nodes (Table 35). Eight satellite clusters and the central node CA8 (haplogroup A2) coalesced at  $20,773 \pm 14,309$  years before present (YBP). This time estimate is consistent with previous studies of the American origin for haplogroup A2 (Achilli et al. 2008; Melton 2008; Tamm et al. 2007).

Individual satellite nodes of haplogroup A2 coalesced between 20,180 and 6726 YBP. The most recent of these haplotypes are associated with Rama Cay and the most ancient are shared between Punta Aguila, Greytown, and Zompopera. Contrary to this scenario, haplotypes that belong to the haplogroup B2 coalesced at  $3463 \pm 1116$  YBP. Individual haplotypes of more recent origin coalesced between 171 and 1009 YBP and are more common in Rama Cay. Only one satellite node, CA23, is represented in Punta Aguila.

Table 35. Most frequent satellite nodes among Rama communities and coalescent YBP.

Haplogroup	Satellite node	Most frequent in:	$\rho^*$	Years Before Present (YBP)*	SD
A2	CA2	Rama Cay	0.33	6726	6666
	CA4	Zompopera, Rama Cay, Greytown	0.95	19,321	2766
	CA5	Punta Aguila	0.88	17,937	7778
	CA22	Rama Cay	0.66	13,453	3333
	CA21	Greytown, Punta Aguila, Zompopera	1.000	20,180	20,180
B2	CA11	Rama Cay	0.050	1,009	504
	CA10	Rama Cay	0.016	342	171
	CA9	Rama Cay	0.016	339	339
	CA25	Rama Cay	0.040	827	827
	CA19	Rama Cay	0.016	339	339
	CA20	Rama Cay	0.008	171	171
	CA24	Greytown	0.016	339	339
	CA23	Punta Aguila	0.025	513	241

(\*) Coalescent years from central nodes CA1 and CA8 were calculated as one mutational event every 20,180 years (Saillard et al. 2000).

## Multidimensional Scaling Plot

In order to ascertain the relationship between the six Rama subpopulations a multidimensional scaling plot (MDS) was constructed using mtDNA HVS-I sequence data (Fig. 42). The stress value of this plot is 0.0001 and the goodness of fit is high (0.97,  $p < 0.05$ ), indicating that the genetic relationship of the Rama subpopulations is non random (Manly 2005). The MDS plot shows that Rama Cay and Sumu Kat form a cluster in close proximity to Zompopera (second and third dimension). Indian River and Greytown define the second cluster (first and second dimension), and Punta Aguila is isolated at the base of the MDS plot.

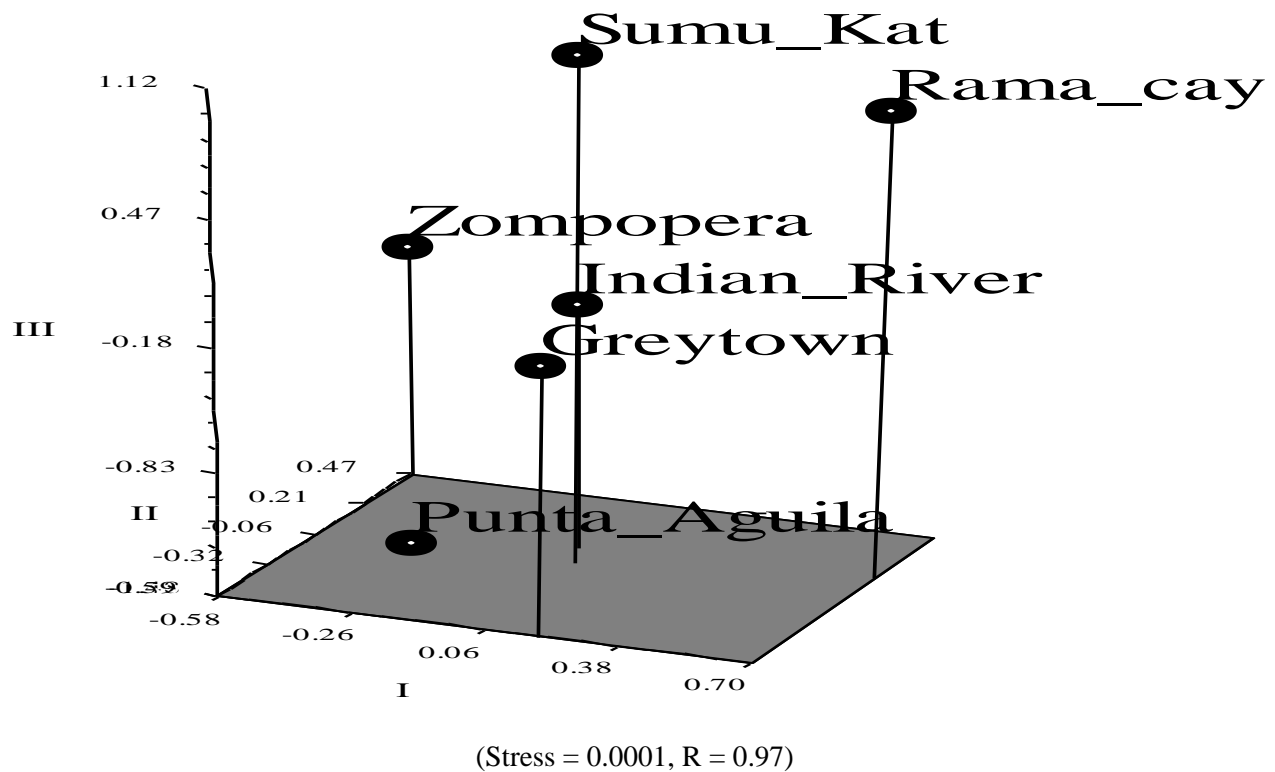

Figure 42. MDS plot of mtDNA HVS-I pairwise genetic differences using the Tamura and Nei (1993) model of nucleotide substitution  $\gamma = 0.26$  between six Rama subpopulations.

The MDS demonstrates that Punta Aguila is an isolated population in relation to peripheral communities of the northern boundary of the territory made up of Rama Cay, Sumu Kat, and Zompopera, and the southern boundary which includes Greytown and Indian River.

**R-Matrix**

The PCA of the *R*-matrix (Fig.43) compares the genetic relationship between six Rama subpopulations and accounts for 80% of the total genetic variation based on mtDNA haplotype diversity.

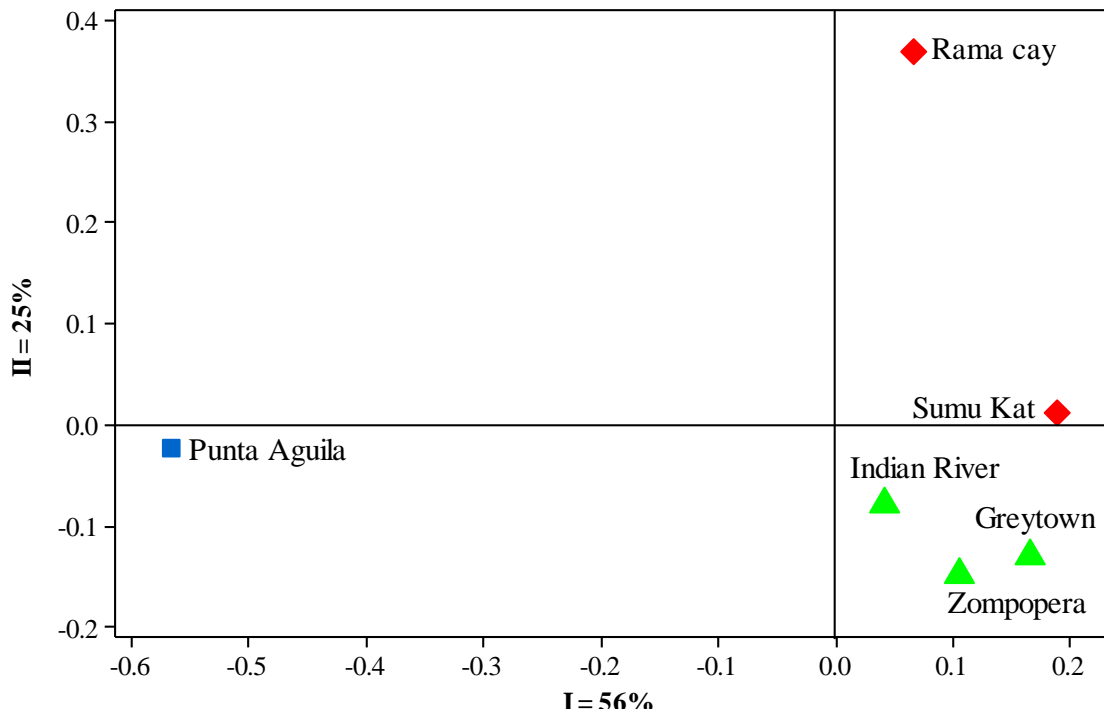

Figure 43. PCA of the *R*-matrix of the Rama subpopulations using mtDNA HVS-I.

The first dimension accounts for 56% of the variation and the second dimension for the remaining 25%. The first dimension of this plot separates Rama Cay, Sumu Kat, Indian River,

Greytown, and Zompopera from Punta Aguila. In the second dimension, Punta Aguila has a closer relationship with Indian River, Greytown and Zompopera and is more distant relation with Rama Cay and Sumu Kat. In general, the *R*-matrix is concordant with the previous MDS plot in which Indian River is the most isolated. This isolation is interpreted as a result of reduced gene flow between other peripheral Rama subpopulations and Punta Aguila. Clusters are caused by differences in haplogroup frequencies. Rama Cay and Sumu Kat have the highest frequency of haplogroup B2 with respect to the lower cluster that includes Indian River and Greytown. Zompopera has equal frequencies of B2 and A2. In Punta Aguila, A2 is predominant, for this reason it is an outlier in the diagram.

### **Genetic Diversity and Neutrality Tests among Six Rama Subpopulations**

In order to assess genetic diversity values ( $H$ ), the number of variant sites ( $\Theta_s$ ), the nucleotide diversity ( $\Theta_\pi$ ), and the forces of evolution acting on the studied Rama subpopulations, five tests statistics were calculated (Table 36). Gene nucleotide diversity show very little difference between subpopulations compared to the other parameters of diversity ( $\Theta_s$  and  $\Theta_\pi$ ). Among the subpopulations, fewer variant sites were found in Zompopera ( $\Theta_s = 2.15 \pm 0.93$  [SD]), Sumu Kat ( $\Theta_s = 2.46 \pm 1.20$  [SD]), Indian River ( $\Theta_s = 2.82 \pm 1.45$  [SD]), and Punta Aguila ( $\Theta_s = 3.05 \pm 1.33$ [SD]).

Table 36. Diversity and neutrality tests among Rama subpopulations

Statistics	Sumu Kat	Punta Aguila	Indian River	Greytown	Zompopera	Rama Cay
Sample size	5	21	10	41	37	80
Gene diversity $H$	$1.00 \pm 0.02$	$1.00 \pm 0.01$	$1.00 \pm 0.04$	$1.00 \pm 0.01$	$1.00 \pm 0.01$	$1.00 \pm 0.00$
$\Theta_s$	$2.46 \pm 1.20$	$3.05 \pm 1.33$	$2.82 \pm 1.45$	$4.44 \pm 1.59$	$2.15 \pm 0.93$	$10.90 \pm 3.07$
$\Theta_\pi$	$3.30 \pm 2.02$	$4.19 \pm 2.42$	$4.90 \pm 2.95$	$4.96 \pm 2.73$	$4.93 \pm 2.73$	$5.28 \pm 2.85$
Tajima's $D$	0.42	0.71	1.99	-0.25	2.7	-2.05*
Fu's $F_s$	-17.16**	-24.69**	-6.74**	-25.83**	-25.80**	-25.90**

\*= $P < 0.05$ , \*\* =  $P < 0.001$

Rama Cay and Greytown contain more variant sites between sequences. Nucleotide diversity values are lower in Sumu Kat ( $\Theta_\pi = 3.30 \pm 2.02$  [SD]) and Punta Aguila ( $\Theta_\pi = 4.19 \pm 2.42$ [SD]) in comparison to higher values that are found in the remaining communities. The relationship of the number of variant sites and nucleotide diversity values give negative scores for the Tajima's  $D$  statistic in Greytown (-0.25) and Rama Cay (-2.05); however, only the value obtained for Rama Cay is significant. It has been proposed that negative scores are indicative of an excess of low frequency mutations in star-like phylogenies and therefore of population expansion (Tajima 1989). The second test of selective neutrality Fu's  $F_s$  indicates that all six Rama communities are subpopulations under expansion because they have significant negative  $F_s$  values. This test statistic is more sensitive to population growth compared to Tajima's  $D$  (Ramos-Onsins and Rozas 2002).

### Mismatch Distribution

In addition to neutrality tests statistics, population expansion or stability can be detected by the type of distribution of the pairwise differences between HVS-I sequences (Rogers and Harpending 1992). However, it has been proposed that population substructure and mutation rate heterozygosity might also account for multimodal distributions and therefore lead to



misinterpretations (Rubicz et al. 2007). This is because in absence of recombination between haplogroups, each haplogroup evolved independently after the peopling of the Americas. In order to explore whether population substructure accounts for the overall mismatch distribution within the Rama, two separate analyses were performed, the first one compares the overall mismatch distribution of the Rama with respect to each subpopulation. The second mismatch analysis explores the contribution of haplogroups A2 and B2 in relation to the overall mismatch for the Rama. Haplogroup C1 was excluded from this analysis due to its small sample size ( $n=1$ ).

The mismatch distribution of the Rama (Fig.44) is multimodal with a first peak at zero pairwise differences, the second mode at five pairwise differences and the third at eight pairwise differences. The raggedness index of 0.225 indicates that the Rama is a stable population, thus more mutations are expected to be shared among individuals from different communities (Jobling et al. 2004).

Examination of mismatch distribution for individual haplogroups demonstrates that haplogroup B2 is unimodal with a peak at zero pairwise differences whereas A2 has two modes, one at zero and the second at 2 pairwise differences. This suggests that haplogroup B2 has experienced a recent population expansion while A2 is characterized by an ancient expansion (2 mutational units) followed by drift (1 mutational unit) and subsequent recent expansion (between 1 and 0 mutational units). It is possible that the overall Rama mismatch distribution reflects two different population histories rather than continuous population stability. In synthesis, the population substructure of the Rama indicates two simultaneous events: Haplogroup A2 experienced two expansions, one ancient and one recent, while B2 only experienced a recent expansion that overlaps with the last demographic event of A2.

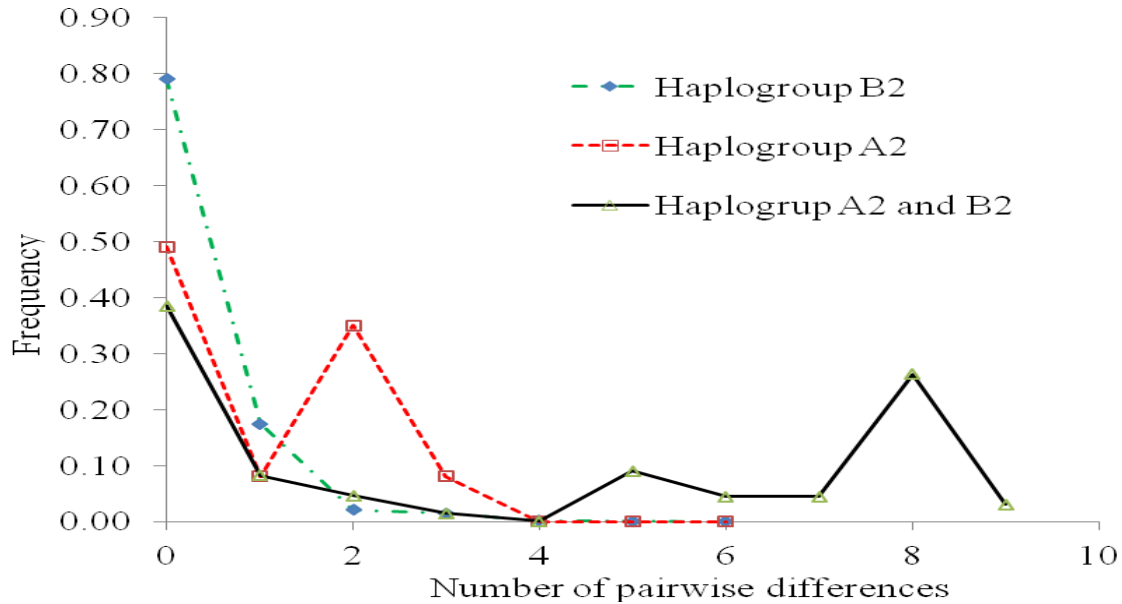

Figure 44. Mismatch distribution for the Rama and comparative mismatch distribution for haplogroup A2 and B2.

Table 37 displays tau values ( $\tau$ ), or the mean number of pairwise differences, the range on the 95% confidence interval limits (CI), and the raggedness index ( $r$ ).  $\tau$  value obtained for haplogroup A2 is 2.146. Time estimates based on this value show that a population expansion is likely to have happened around 20,000 years ago, followed by a population contraction (between 20,000 and 10,000 YBP) and a subsequent expansion after 10,000 YBP. These results are consistent with the coalescence times for different haplotypes using the  $\rho$  parameter (~20,000 and ~6,700 YBP) (see Table 37). Fu's  $F_s$  indicates a significant value that suggests a population explosion for haplogroup A2 compared to the non significant Tajima's  $D$  positive value indicative of genetic drift. The unimodal shape of B2 and coalescence time indicates that this haplogroup has experienced a more recent population expansion in the last 1,500 years. Fu's  $F_s$  and Tajima's  $D$  negative values are consistent with this interpretation.

Table 37. Time estimates and neutrality test values for haplogroups A2 and B2.

Rama population	N	<i>r</i>	<i>D</i>	<i>F<sub>s</sub></i>	$\tau$ (95% C.I)	Time estimate YBP [CI]†
Haplogroup A2	68	0.31	0.46	-30**	2.146 (6.458 - 3.983)	20,060 (60,059 - 37,041)
Haplogroup B2	132	0.40	-1.9**	-34**	0.161 (0.000 - 1.480)	1497 (0 - 13,764)
Haplogroup A2 and B2	200	0.21	0.43	-26**	6.494 (0.257 - 18.389)	60,394 (2,390 - 171,017)

(†) time estimates were calculated as one mutation every 9300 years (Ward et al. 1991). \*\*=  $p < 0.001$

The resulting chronology from haplogroup A2 and B2 shows a consistent time estimated of ~60,000 YBP of an ancient population explosion in the Pleistocene and seen among Chibchans and other populations in the world (Kolman and Bermingham 1997; Rogers and Harpending 1992).

Figure 45 presents a mismatch distribution examining the pairwise differences and the shapes of the histograms of six Rama subpopulations using haplogroup A2 and B2. In general, the shapes of all histograms are sinusoidal showing small and large peaks every two mutational units; however, they vary in frequency. The heights of these peaks are present at 0, 6, and 8 mutational units and the lower at 2, 4, and 10 mutational units. A general pattern that emerges from this comparison is that Punta Aguila has the highest frequency at six mutational units and the lowest frequency at 8 compared to the other communities.

It can be interpreted that the general shape of the mismatch distribution and associated stochastic effects are dependent on individual subpopulations and their genetic variation, accounting for the difference between Punta Aguila and the rest of the communities.

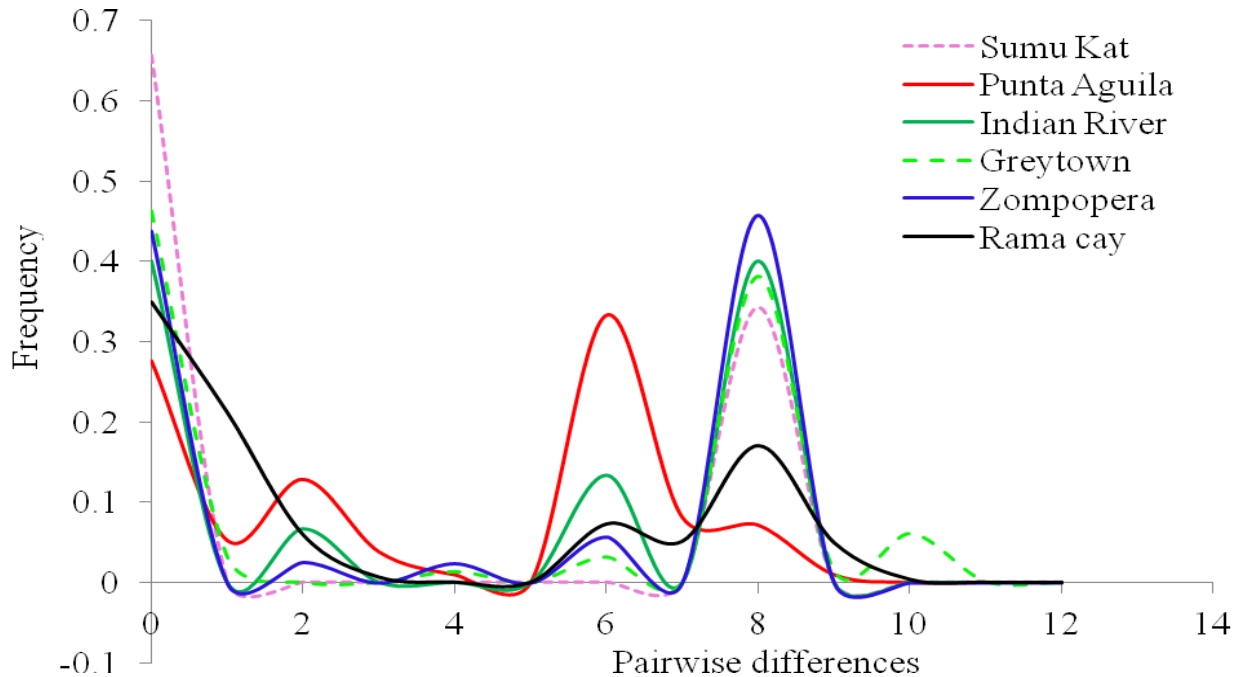

Figure 45. Mismatch distribution for six Rama subpopulations.

### Genetic Barriers and Phylogeographic Analysis

In order to explore possible genetic barriers of gene flow, Monmonier's algorithm was applied to a  $F_{st}$  distance matrix of HVS-I sequences of six Rama subpopulations. Figure 46 includes information on genetic barriers between populations, approximate geographic locations where genetic barriers are more statistically robust, and the direction of such barriers. The diagram illustrates connections of localities as determined by Delaunay triangulation which established the most robust genetic barrier of gene flow (a-a) around Punta Aguila, separating this locality from the rest of communities. The approximate location of the barrier is between the Indio Maiz River to the south and the Bay of Bluefieds to the north. The second most robust

barrier (b-b) isolates Zompopera from Sumu Kat and Rama Cay. A possible geographic barrier between Zompera and Sumu Kat and Rama Cay is the Kukra River and surrounding forests.

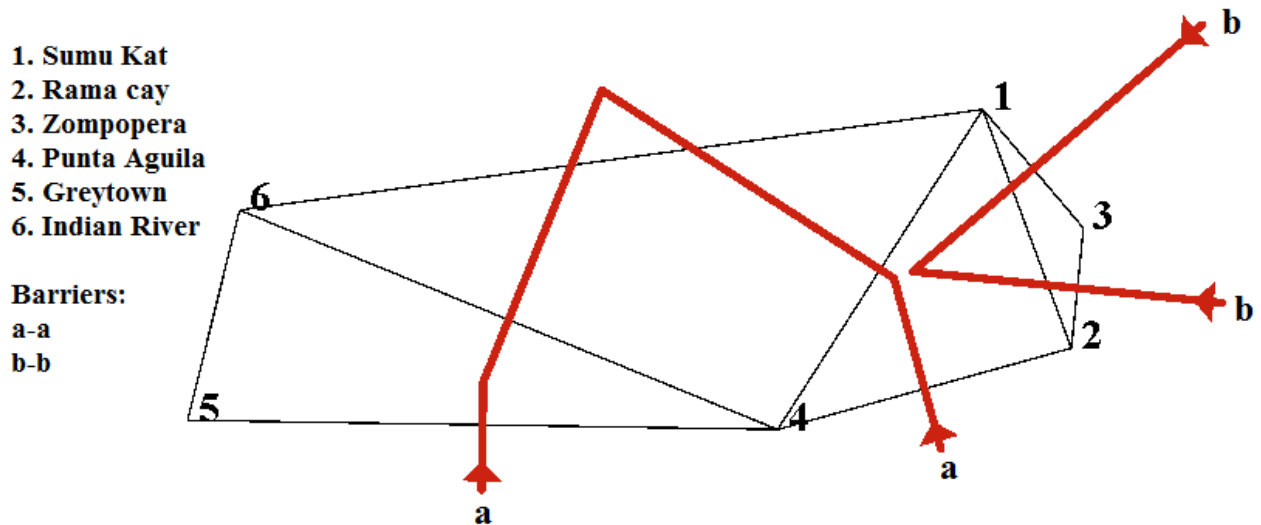

Figure 46. Delaunay triangulation using the Monmonier's algorithm. Thin lines connect Rama localities crossed by barriers of gene flow that are represented by arrows and thick lines.

The interpolated genetic landscape resulting from the analysis of HVS-I mtDNA sequences of six Rama communities generated a three dimensional diagram in which more genetic similarity is found at associated points that are positioned in depressions and elevations. The X/Y axes represent geographic coordinates. Valleys below the X/Y plane represent more genetic similarities and elevations above the X/Y plane represent greater genetic differentiation among populations. The Z-axis represents the pairwise genetic similarity or difference of pairs' populations. Figure 47 depicts the genetic associations between Rama localities. Punta Aguila is, according with this diagram, the most isolated population and is located between elevations or barriers of gene flow. Zompopera also is isolated from Rama Cay and Sumu Kat by a depression in the genetic landscape. Indian River and Greytown are closely related.

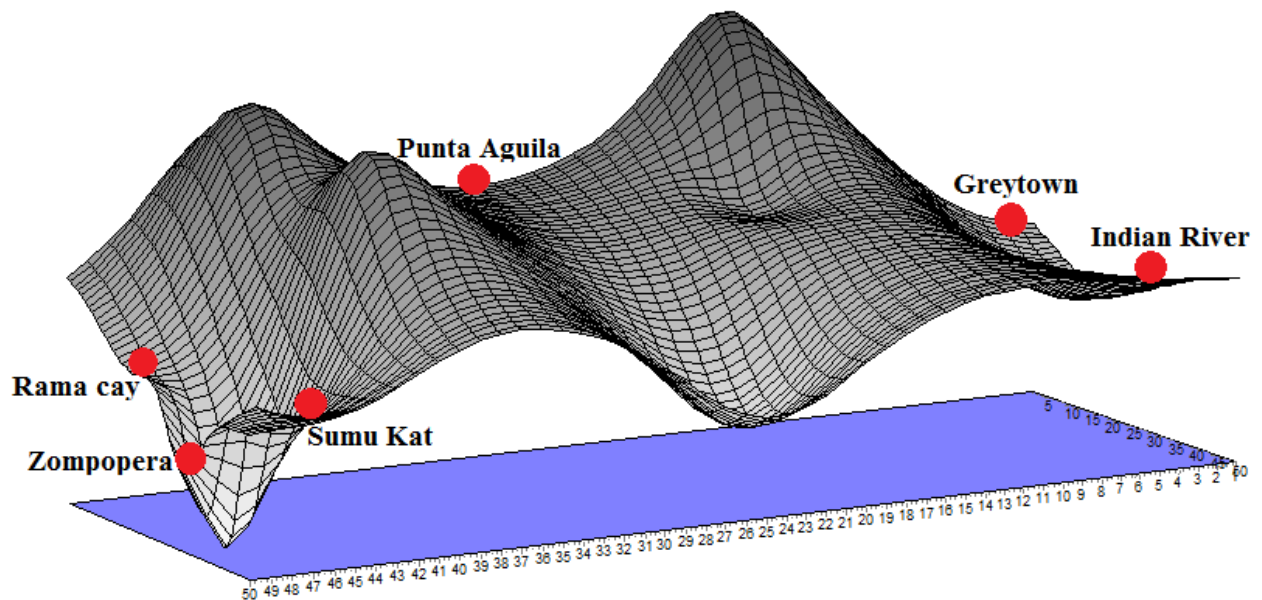

Figure 47. Interpolated genetic landscape of six Rama localities.

### **Analysis of Molecular Variance (AMOVA)**

Three different hierarchical models were tested using AMOVA in order to investigate the presence of genetic structuring within the Rama. The first model includes all subpopulations, the second AMOVA is based on the geographic separation of northern (Sumu Kat, Rama Cay, and Zomopera), central (Punta Aguila) and southern Rama localities (Indian River and Greytown). The third AMOVA tested two groups based on kinship relationships. The first of these groups represent central populations (Punta Aguila), and the second group of peripheral populations includes the remaining five localities of the Rama territory.

Table 38 presents the results of the first AMOVA performed on the six Rama subpopulations. This shows that most of the HVS-I variation is found within communities

(94%), whereas 6% is attributed between communities. The fixation index ( $F_{st}$ ) that accounts for population differentiation due to genetic structure is 0.059 and is statistically significant.

Table 38. AMOVA between all Rama subpopulations.

Source of variation	D.F.	Sum of Squares	Variance components	Percentage of Variation	$F$ -statistic	$P$ -value
Among subpopulations	5	35.876	0.15366	6		
Within subpopulations	198	484.080	2.44485	94		
Total	203	519.956			$F_{st} = 0.0591$	$< 0.005$

Results of the AMOVA based on geographic subdivision of northern, central, and southern communities are shown in table 39. The amount of variation within subpopulations, 94%, and the variation among subpopulations and between groups, 5.7%, were significant; however, the variation among predefined geographic groups was very low (0.5) and non significant ( $p > 0.05$ ).

Table 39. AMOVA for Rama subpopulations based on three geographic groupings: north, central, and south.

Source of variation	D.F.	Sum of Squares	Variance components	Percentage of Variation	$F$ -statistic	$P$ -value
Among groups	2	13.433	0.0108	0.5	$F_{ct} = 0.0049$	ns
Among subpopulations between groups	3	16.964	0.12378	5.7	$F_{sc} = 0.0571$	$< 0.05$
Within subpopulations	198	404.634	2.04361	93.8	$F_{st} = 0.0618$	$< 0.05$
Total	203	435.031	2.17825			

The results of the last AMOVA, grouping the Rama subpopulations according to major kinship relationships of central and peripheral locations, is shown in table 40.

Table 40. AMOVA based on central and peripheral groups.

Source of variation	D.F.	Sum of Squares	Variance components	Percentage of Variation	$F$ -statistic	$P$ -value
Among groups	1	12.287	0.22234	9.5	$F_{ct} = 0.0949$	$< 0.001$
Among subpopulations between groups	4	18.110	0.07667	3.3	$F_{sc} = 0.0361$	$< 0.05$
Within subpopulations	198	404.634	2.04361	87.2	$F_{st} = 0.1276$	$< 0.05$
Total	203	435.031	2.34262			

The analysis reveals that the highest variation is present within individual subpopulations, 87.2%, and among groups, 9.5%. The fixation index  $F_{ct} = 0.09$  ( $P < 0.001$ ) accounts for the variation among groups and better explains the population structure of the Rama compared to the previous AMOVA model. 3.3% of the variation is explained among communities between groups.

### **REGIONAL GENETIC STRUCTURE**

mtDNA and classical genetic markers were used to evaluate the genetic relationship between the Rama and among other populations from Mesoamerica, Central America, northern South America, and the Caribbean. Between groups, variation analyses included median joining networks, multidimensional scaling (MDS), analysis of molecular variance (AMOVA), and median joining networks,  $R$ -matrix regressed on diversity, and a phylogeographic analysis based



on the Monmonier algorithm. Within groups, performed variation analyses included tests of selective neutrality and diversity tests to assess which forces of evolution are acting on populations.

### **Gene Diversity and Neutrality Tests for Comparative Populations**

Haplotype ( $H$ ) and nucleotide diversity ( $\pi$ ) values, number of polymorphic sites and haplotypes, as well as selective neutrality tests were calculated for comparative populations among four geographical regions: Mesoamerica, Central America, Northern South America, and the Caribbean. Results of these analyses are shown in table 41.

Among the investigated Chibchan speaking populations from Central America and Colombia, the Rama has the highest number of Native American haplotypes (16) and a moderate haplotype diversity value of 0.637. This value suggests a relatively low genetic diversity share among individuals and within the Rama population. In other words, less genetic polymorphisms are shared between individuals. Similar interpretation is also valid for the Chibchan populations from South America, the Kogi and Arsario, as well as for the Central American Kuna, Ngöbé, Huetar, and Guaymí. Compared to Mesoamerican populations and non-Chibchans from South America, haplotype diversity values are higher ( $> 0.65$  and  $> 0.9$ ) for most of the populations, suggesting the opposite scenario.

All Chibchan populations including the Rama have low nucleotide diversity values, between 0.005 and 0.15, compared to Mesoamerican and non-Chibchans from South America ( $\pi$  values between 0.011 and 0.024).

Two neutrality tests, Tajima's  $D$  and Fu's  $F_s$ , were calculated among these populations. Negative Tajima's  $D$  values among the Chibchan populations, Rama, the Ijka, and Guatuso indicates population expansion; however, only the Ijka and Guatuso have significant values ( $p < 0.05$ ). According with Melton (2008: 122), significant Tajima's  $D$  is likely to be a statistical artifact for these two last populations due to their low haplotype diversity that inflates the overall Tajima value.

Like Tajima's  $D$ , Fu's  $F_s$  negative value is an indicator of population expansion. Negative values are present among the Chibchan Rama, Ijka, and Huetar; however, only the Huetar have a statistically significant value. According with these results the signature of expansion is more frequent among Mesoamerican, Caribbean, and non-Chibchan from South America.

Table 41. Diversity values and neutrality tests of 24 selected Mesoamerican, Central American, Caribbean, and South American populations based on mtDNA HVS-I sequence data.

Population	N	Haplotypes	Polymorphic sites	<i>Hapl. Div.</i> <i>H</i>	Nucl. Div. $\pi$	<i>D</i>	<i>F<sub>S</sub></i>
<b><i>Rama</i><sup>1</sup></b>	<b>131</b>	<b>16</b>	<b>23</b>	<b>0.637</b>	<b>0.013</b>	<b>-0.38</b>	<b>-0.47</b>
<b><i>Ijka</i><sup>2</sup></b>	31	3	12	0.185	0.005	-1.58*	-2.96
<b><i>Guatuso_M</i><sup>3</sup></b>	14	3	9	0.274	0.005	-1.93*	1.63**
<b><i>Kogi</i><sup>2</sup></b>	21	3	10	0.524	0.011	0.58	5.40
Triqui <sup>13</sup>	107	15	27	0.548	0.016	-0.37	0.18
<b><i>Kuna</i><sup>4</sup></b>	63	7	10	0.592	0.012	1.52	2.78
Shamatari <sup>8</sup>	155	6	14	0.657	0.013	1.35	7.31
Chorotega_M <sup>3</sup>	24	6	14	0.670	0.011	-0.58	1.43
<b><i>Arsario</i><sup>2</sup></b>	28	4	10	0.725	0.014	1.98	5.74
<b><i>Ngöbe</i><sup>6</sup></b>	46	7	12	0.763	0.015	1.68	3.39**
<b><i>Huetar</i></b> (pool) <sup>5</sup>	52	12	19	0.787	0.015	0.07	-0.03**
<b><i>Guaymí</i><sup>3</sup></b>	39	7	12	0.819	0.013	1.02	2.34**
Mixtec <sup>13</sup>	19	10	19	0.825	0.013	-1.23	-2.13
Wayuu <sup>2</sup>	30	6	17	0.825	0.019	0.97	4.63
Cayapa <sup>7</sup>	30	8	18	0.837	0.022	1.15	2.87
Yanomamo <sup>9</sup>	129	3	31	0.906	0.017	-0.47	-9.59*
Wounan <sup>10</sup>	31	14	29	0.912	0.024	-0.27	-1.01
Tainos <sup>11</sup>	19	11	13	0.918	0.010	-0.74	4.21*
Yucatec <sup>12</sup>	52	20	27	0.922	0.020	-0.11	-3.68
K'iche' <sup>13</sup>	34	18	27	0.931	0.020	-0.58	-4.90**
Emberá <sup>11</sup>	44	20	23	0.942	0.021	0.46	-4.38
Ciboney <sup>14</sup>	15	10	12	0.943	0.011	-0.38	-3.68*
Otomi <sup>13</sup>	68	32	38	0.967	0.024	-0.44	-11.58*
Purepecha <sup>13</sup>	34	23	37	0.973	0.023	-0.98	-9.75*

\* =  $P < 0.05$ , \*\* =  $P < 0.001$ . Chibchan populations are in bold letters. 1) This study, 2) Melton et al.(2007), 3) Melton (2008), 4) Batista et al.(1995), 5) Melton (2008), Santos et al.(1994), 6) Kolman et al.(1995), 7) Rickards et al. (1999), 8) Williams et al.(2002), 9) Merriwether et al.(2000), 10) Kolman and Bermingham (1997), 11) Lalueza-Fox et al.(2001), 12) Sandoval et al.(2009), 13) Boles et al. (1995), Torroni et al.(1993), 14) Lalueza-Fox et al. (2003).

## Multidimensional Scaling (MDS) and R-matrix analyses

MDS plots and a PCA of an R-matrix were generated in order to ascertain the relationship of the Rama among comparative populations from Mesoamerica, Central America, the Caribbean, and northern South America. MDS analysis (Fig.48) was constructed using mtDNA HVS-I genetic distances (Nei 1987) under the nucleotide substitution model  $\gamma = 0.26$  (Meyer et al. 1999; Tamura and Nei 1993). The stress value (0.11) indicates that data is not randomly distributed in the plot, and the goodness of fit (0.96,  $P < 0.05$ ) is high. Four main clusters of populations are divergent in the MDS plot. Most of the Chibchan populations from Central and South America share the upper and lower right quadrant as a unit. Nevertheless, some Mesoamerican populations such as the K'iche', the Triqui, and the Mixtec, are in close proximity to Central American Chibchans. The Chorotega, considered an Oto-Manguean speaking population of Mesoamerican origin, is closer to Central and South American Chibchans. This relationship can be explained by the high frequency of haplogroup A2 among these populations and shared haplotypes (see median network analysis: Fig.52 and Fig.53).

Most Mesoamerican populations are located close to the centroid of the plot and share the four founding haplogroups (proportions  $A > B > C > D$ ). Two extinct Caribbean populations, the Ciboney and the Taino, cluster at the left upper corner of the plot and they exhibit the absence of haplogroup A2 and B2 and high frequencies of C1 and D1. Non-Chibchan South American populations cluster in the left side of the plot where haplogroup B2 is predominant followed by C1, A2, and the less frequent haplogroup D1. Because the Rama has higher frequencies of haplogroup B2 and very few of C1 this population is located in the lower center of the MDS plot.

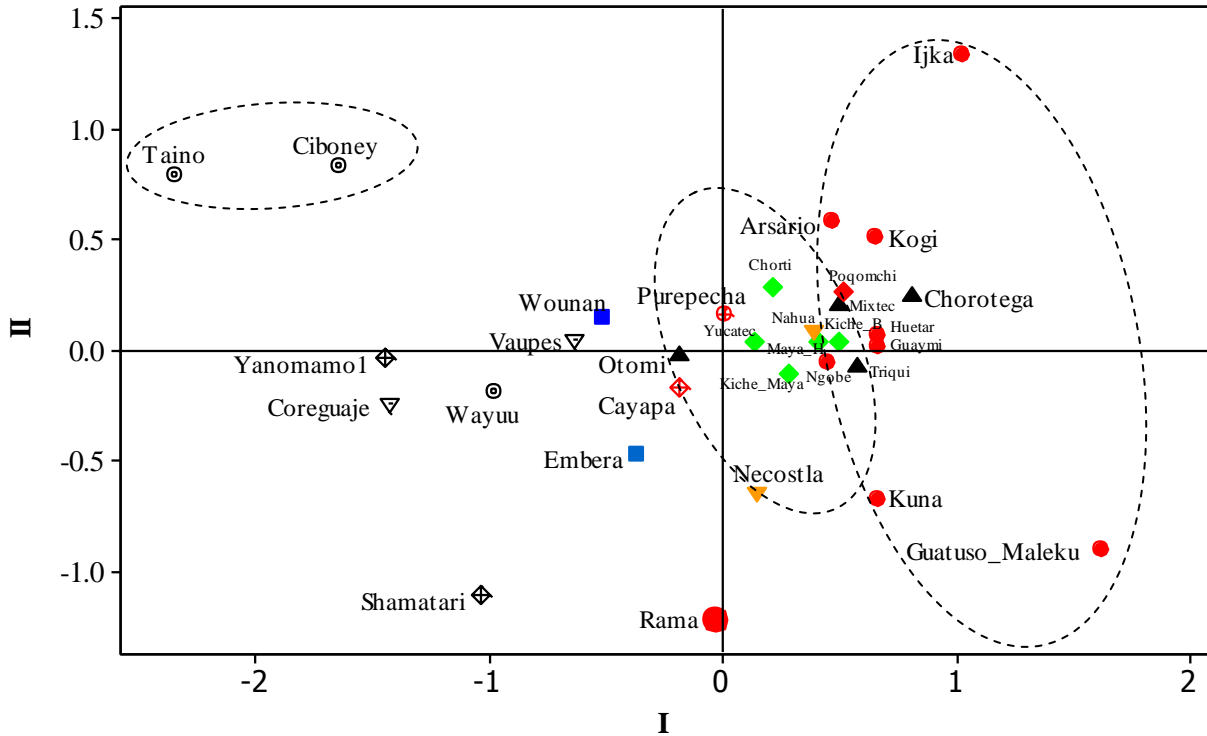

Figure 48. MDS of mtDNA genetic distances among comparative populations from Mesoamerica, Central America, and northern South America. Plot was constructed from pairwise  $F_{st}$  using Tamura Nei assumption of  $\gamma = 0.26$ .

In order to ascertain the relationship of nine Chibchan and one Oto-Manguean (Chorotega) population from Central and South America an MDS based on pairwise  $F_{st}$  distances was constructed and is shown in figure 49. The stress value for this plot was moderate 0.15 and high goodness of fit ( $0.97, P < 0.05$ ) indicating that the data points are not randomly distributed in the plot (Manly 2005). There are three different clusters that can be visualized. In the lower left side South American Chibchans cluster together (Ijka, Arsario, and Kogi). The central cluster includes Central American Chibchans (Huetar, Guaymí, and Ngöbé) and the Chorotega from Costa Rica. The Rama shares a closer genetic relationship with the Kuna from the Caribbean

coast of Panama and a distant genetic relationship with the Guatuso-Maleku due to mirroring haplogroup frequencies.

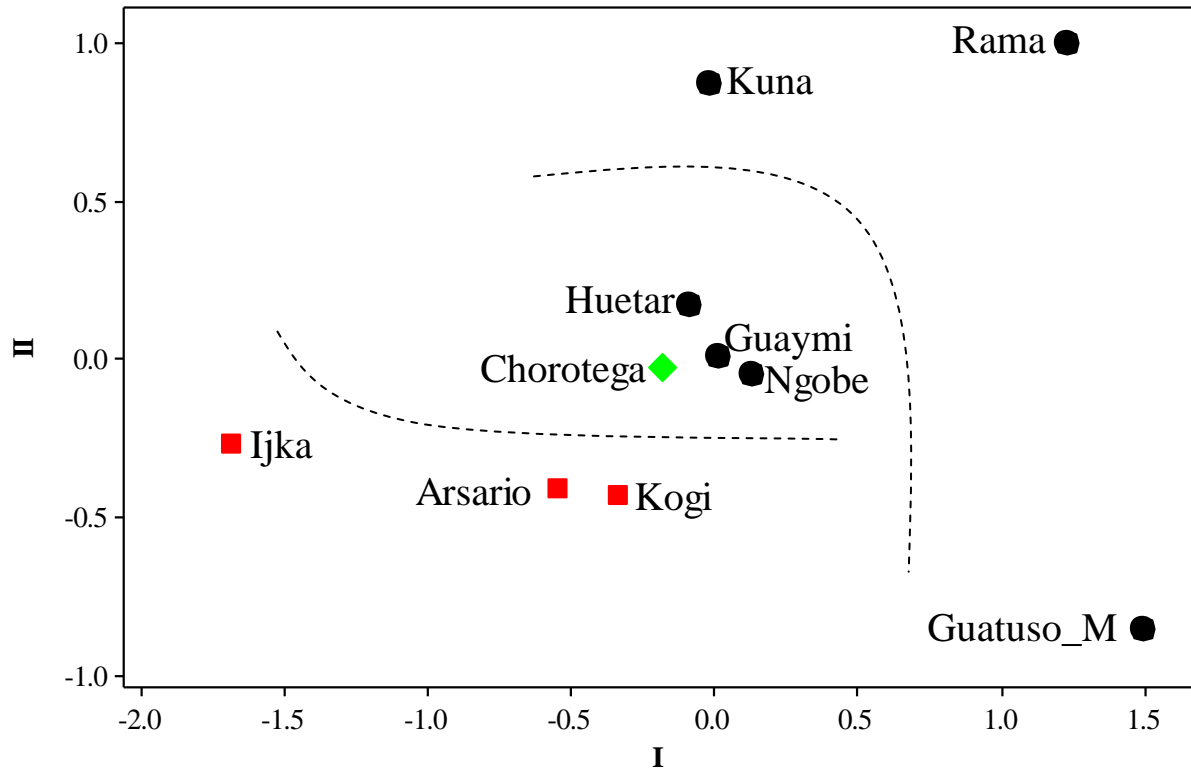

Figure 49 MDS of nine Chibchan populations and one Oto-Manguean (Chorotega). Plot was constructed from pairwise  $F_{st}$  using Tamura Nei assumption of  $\gamma = 0.26$ . South American Chibchans are represented with squares, Chibchan populations from Central America are represented with dots, and the Chorotega with a rhomboid.

In addition to the previous analysis an  $R$ -matrix was calculated using 22 alleles of seven blood group systems (MNSs, P, Kidd, Diego, Rhesus, ABO, and Duffy) from literature (Table 42). This analysis explores the genetic relationships of different ethno-linguistic groups from Mesoamerica, Central America, and South America including populations not tested in the

previous MDS. Because alleles of these blood group systems are located in autosomal DNA, they can be used to compare the genetic variation and structure of populations (Mielke et al. 2006). The PCA of the *R*-matrix of classical genetic polymorphisms is displayed in figure 50.

The first and second dimension of the PCA explains 45% of the total genetic variation. This diagram separates two major groups, the Chibchan speakers from Central America and South America (dot symbols) and a group that includes mainly Mesoamerican populations.

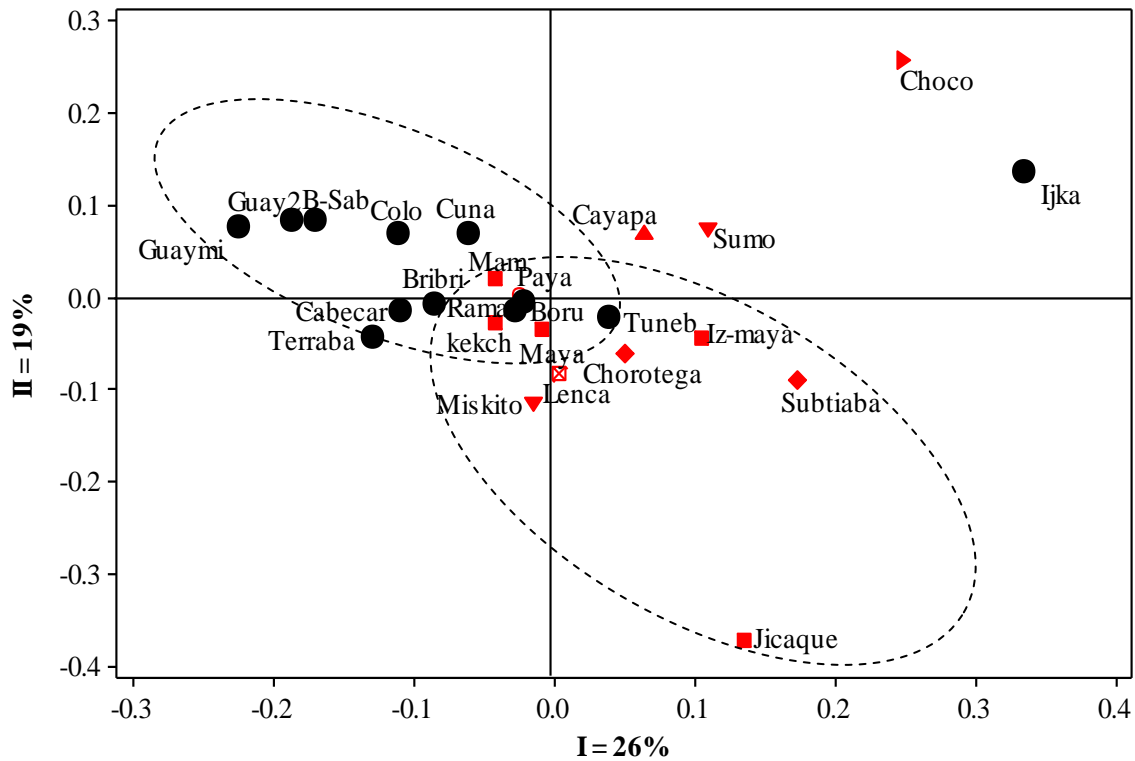

Figure 50. PCA of the *R*-matrix of 24 comparative populations using 22 alleles of 7 blood group systems from literature.

Close to the centroid, these two groups share a number of populations, the Chibchan speakers: Rama, Boruca, and Tunebo, as well as the Maya speakers: Maya, Mam, and Kekchi. Misumalpan speaking Sumu and the Barbacoan Chocoan are clustered with the Ijka and the Chocó in the upper right quadrant of the plot. Two blood group systems demonstrated being fixed (Diego [ $D_i^b$ ]) or nearly fixed (ABO) in eight Chibchan populations from Central America.

### **Heterozigosity Versus $r_{ii}$**

Figure 51 displays the regression plot of heterozigosity values and distance from the centroid ( $r_{ii}$ ) for 24 Indigenous populations from Central America and South America using 7 blood group systems. Ten Chibchan populations (dot symbols) out of a total 12 demonstrate lower genetic heterozigosity according with the theoretical regression line. The remaining 12 populations above the regression line, from which 9 are non-Chibchan populations, demonstrate greater than expected diversity.



Table 42. Allelic frequencies from segregating classical polymorphism in Central and South American indigenous Populations

Alleles	GUATEMALA		HONDURAS		BELICE		NICARAGUA					
	Mam <sup>1</sup>	K'ekchi <sup>1</sup>	Jicaque <sup>2</sup>	Lenca <sup>2</sup>	Payá <sup>2</sup>	Izta-Maya <sup>3</sup>	Maya <sup>3</sup>	Sumo <sup>4</sup>	Rama <sup>4</sup>	Miskito <sup>4</sup>	Chorotega <sup>4</sup>	Subtiaba <sup>4</sup>
<b>MNSs</b>												
MS	0.168	0.254	0.344	0.344	0.281	0.254	0.292	0.741	0.228	0.49	0.287	0.321
Ms	0.483	0.422	0.419	0.419	0.455	0.422	0.408	0.157	0.272	0.28	0.453	0.455
NS	0.116	0.036	0.127	0.127	0.049	0.036	0.075	0.094	0.137	0	0.076	0.11
Ns	0.233	0.288	0.11	0.11	0.215	0.288	0.225	0.008	0.363	0.23	0.183	0.114
<b>P</b>												
P1	0.517	0.607	0.603	0.603	0.434	0.427	0.556	0.385	0.597	0.617	0.503	0.475
P2	0.483	0.393	0.397	0.397	0.566	0.573	0.445	0.615	0.403	0.383	0.497	0.525
<b>Kidd</b>												
a	0.257	0.378	0.342	0.342	0.327	0.409	0.425	0.481	0.535	0.373	0.477	0.413
b	0.743	0.622	0.659	0.659	0.673	0.591	0.575	0.519	0.466	0.627	0.523	0.587
<b>Diego</b>												
da	0.053	0.034	0.048	0.048	0.048	0.136	0.045	0.055	0	0.006	0.007	0.109
db	0.947	0.966	0.952	0.952	0.952	0.864	0.956	0.945	1	0.994	0.994	0.891
<b>Rhesus</b>												
CDe(Rz)	0.043	0.023	0.015	0.015	0.016	0	0.004	0.025	0	0.019	0.078	0.084
CDE(R1)	0.604	0.52	0.382	0.382	0.559	0.515	0.547	0.776	0.632	0.537	0.604	0.537
cDE(R2)	0.328	0.422	0.502	0.502	0.324	0.38	0.426	0.101	0.342	0.237	0.227	0.174
other(Ro)	0.025	0.035	0.1	0.1	0.1	0.105	0.023	0.098	0.026	0.207	0.091	0.205
<b>ABO</b>												
O	0.957	0.951	0.907	0.907	0.944	0.866	0.927	1	0.973	0.9	0.922	0.862
A1	0.036	0.025	0.013	0.013	0.019	0.06	0.008	0	0	0.08	0.052	0.069
A2	0.007	0.006	0.053	0.053	0.037	0.03	0.008	0	0.026	0.006	0.013	0
B	0	0.012	0.026	0.026	0	0	0.056	0	0	0.013	0.013	0.069
A1B	0	0.006	0	0	0	0.029	0	0	0	0	0	0
A2B	0	0	0	0	0	0.015	0	0	0	0	0	0
<b>Duffy</b>												
a+(a)	0.773	0.757	0.771	0.771	0.588	0.654	0.723	0.952	0.892	0.7	0.961	0.965
a-(b)	0.227	0.243	0.229	0.229	0.412	0.346	0.276	0.048	0.108	0.3	0.039	0.035
<b>Total (N)</b>	116	162	194	152	53	67	103	248	37	150	77	29

(1) GA Matson, J. Swanson 1963a, (2) GA Matson, J. Swanson 1964a., (3) A Matson, J. Swanson 1964b., (4) A Matson, J. Swanson 1963b, (5) GA Matson, J. Swanson 1963a, (6) Barrantes et al 1982, (7) GA Matson, J. Swanson 1963a, (7) A Matson, J. Swanson 1965b., (8) Lattisse et al (1963), (9) Matson et al. (1966).

Table 42 (cont.)

<i>Alleles</i>	<i>COSTA RICA</i>				<i>PANAMA</i>			<i>COLOMBIA</i>		<i>ECUADOR</i>		
	Terraba <sup>2</sup>	Bribri <sup>2</sup>	Boruca <sup>2</sup>	Guaymi <sup>2,3</sup>	Guaymi <sup>6</sup>	Boc-Sab <sup>6</sup>	Cuna <sup>7</sup>	Choco <sup>7</sup>	Ijka <sup>8</sup>	Tunebo <sup>8</sup>	Colorado <sup>8</sup>	Cayapa <sup>8</sup>
MNSs												
MS	0.169	0.241	0.165	0.221	0.328	0.199	0.235	0.202	0.293	0.342	0.083	0.324
Ms	0.543	0.429	0.505	0.477	0.379	0.397	0.483	0.43	0.576	0.288	0.75	0.506
NS	0.068	0.15	0.073	0.096	0.07	0.104	0.093	0.117	0.097	0.093	0	0.008
Ns	0.219	0.18	0.257	0.206	0.223	0.3	0.189	0.251	0.034	0.277	0.167	0.162
P												
P1	0.776	0.6	0.705	0.577	0.611	0.551	0.607	0.539	0.199	0.322	0.559	0.329
P2	0.224	0.4	0.295	0.423	0.389	0.449	0.393	0.461	0.801	0.678	0.441	0.671
Kidd												
a	0.258	0.307	0.557	0.236	0.096	0.107	0.417	0.419	0.723	0.6	0.423	0.611
b	0.742	0.692	0.443	0.764	0.904	0.893	0.583	0.581	0.277	0.4	0.577	0.389
Diego												
da	0	0	0.074	0.002	0	0	0.048	0.419	0.239	0.005	0.014	0.045
db	1	1	0.926	0.997	1	1	0.952	0.581	0.761	0.995	0.986	0.955
Rhesus												
CDE(Rz)	0	0	0	0.009	0	0	0.018	0.008	0	0	0	0
CDe(R1)	0.375	0.44	0.536	0.865	0.856	0.856	0.705	0.635	0.605	0.345	0.708	0.658
cDE(R2)	0.425	0.49	0.419	0.105	0.13	0.11	0.255	0.285	0.111	0.629	0.278	0.34
other(Ro)	0.2	0.071	0.045	0.021	0.014	0.034	0.022	0.071	0.284	0.026	0.014	0.002
ABO												
O	1	1	0.946	1	0.995	1	1	1	0.982	0.99	1	0.992
A1	0	0	0.018	0	0.005	0	0	0	0.014	0.005	0	0
A2	0	0	0	0	0	0	0	0	0	0	0	0
B	0	0	0.036	0	0	0	0	0	0.004	0.005	0	0.008
A1B	0	0	0	0	0	0	0	0	0	0	0	0
A2B	0	0	0	0	0	0	0	0	0	0	0	0
Duffy												
a+(a)	0.726	0.776	0.537	0.513	0.437	0.606	0.659	0.665	0.77	0.684	0.559	0.752
a-(b)	0.274	0.224	0.463	0.487	0.563	0.394	0.341	0.335	0.23	0.316	0.441	0.248
Total(N)	40	50	56	240	506	104	388	80	113	100	36	244

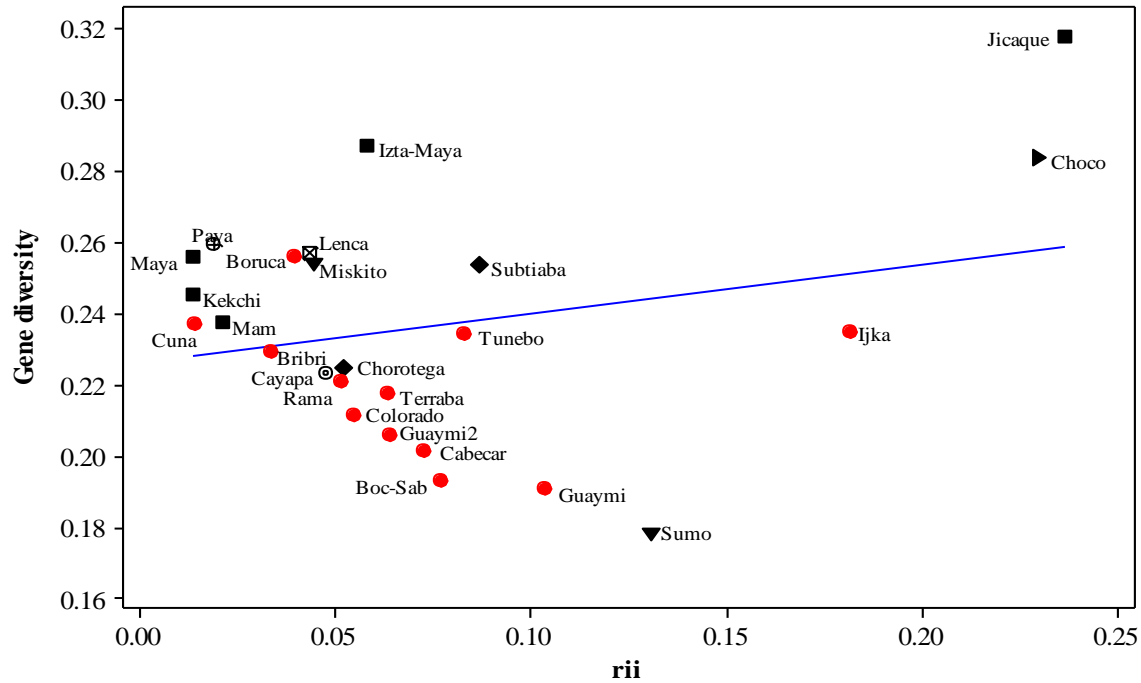

Figure 51. Regression plot of heterozygosity values and distance from the centroid ( $r_{ii}$ ) for 24 Indigenous populations from Central America and South America using 7 blood group systems.

Based on this analysis, the Rama, as well as the majority of Chibchan populations, is experiencing more genetic isolation than other non-Chibchan populations from Central America.

### Median Joining Networks

Five different reduced median networks were constructed from mtDNA HVS-I sequences in order to approximate the most parsimonious relationship between the Rama and other comparative populations from Mesoamerica, Central America, Northern South America, and the Caribbean. Networks were constructed for three haplogroups (A2, B2, and C1) and the linguistic affiliation of the studied populations. Haplogroup D1 was not included in the analysis because is absent among the Rama.

Figure 52 provides a graphical representation of the phylogenetic relationships of haplogroup A2 among aggregates of different linguistic families. The center of the diagram represents a founder cluster shared by Oto-Mangueans, Mayans, Chibchans, Barbacoans, Yanomam, and Tucanoan speakers. Surrounding nodes from this cluster indicate that different haplotypes are undergoing expansion. Rama Amerindians are depicted into circular nodes by red diagonal crossed lines. The Rama shares haplotypes with Chocoans, Chibchans, Mayans, and Oto-Manguean (Chorotega) speakers.

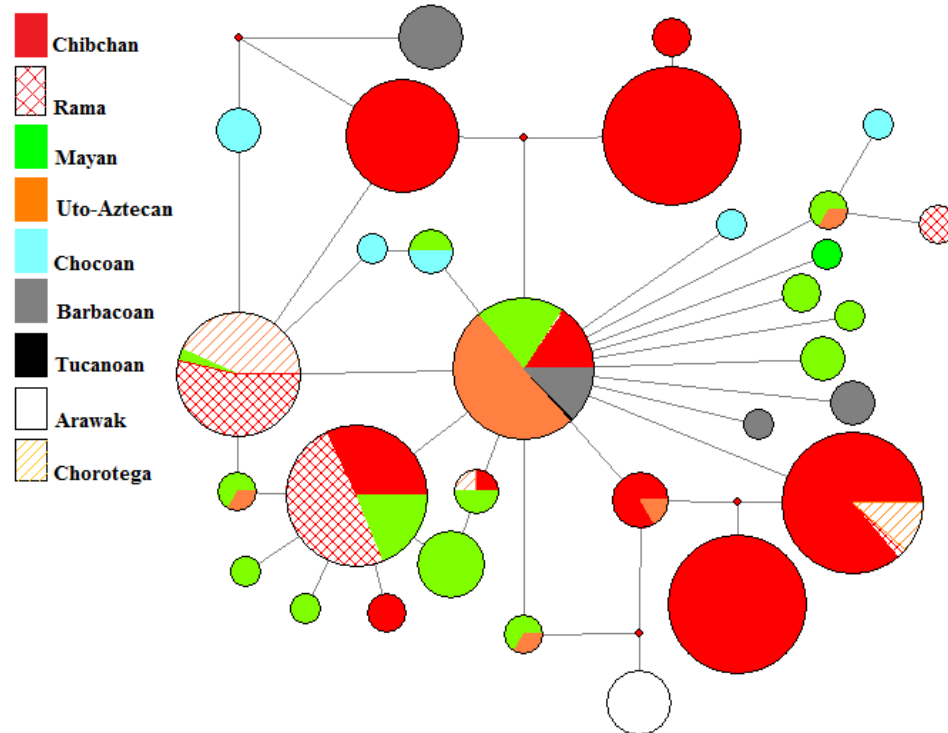

Figure 52. Median Joining network for haplogroup A2 and associated linguistic groups.

In order to gain a better resolution of the phylogenetic relationships from the previous diagram, a network of 13 linked haplotypes of 20 populations was generated as shown in figure 53. In addition, the list of associated populations for each haplotype, or node, is presented in table 43. Sequenced haplotypes are represented by circles, the relative size of which reflects their

frequency. Centered at np 16111, 16187, 16223, 16290, 16319, 16362, cluster G is the most ancient haplotype. The above network includes: Rama, Maleku, Guaymí, Poqomchi', Ch'orti', Cayapa, Ngöbé, Emberá, Wounan, Otomi, Mixtec, Maya, Triqui, and Coreguaje. Additionally, the Rama is present in clades B, M, and D.

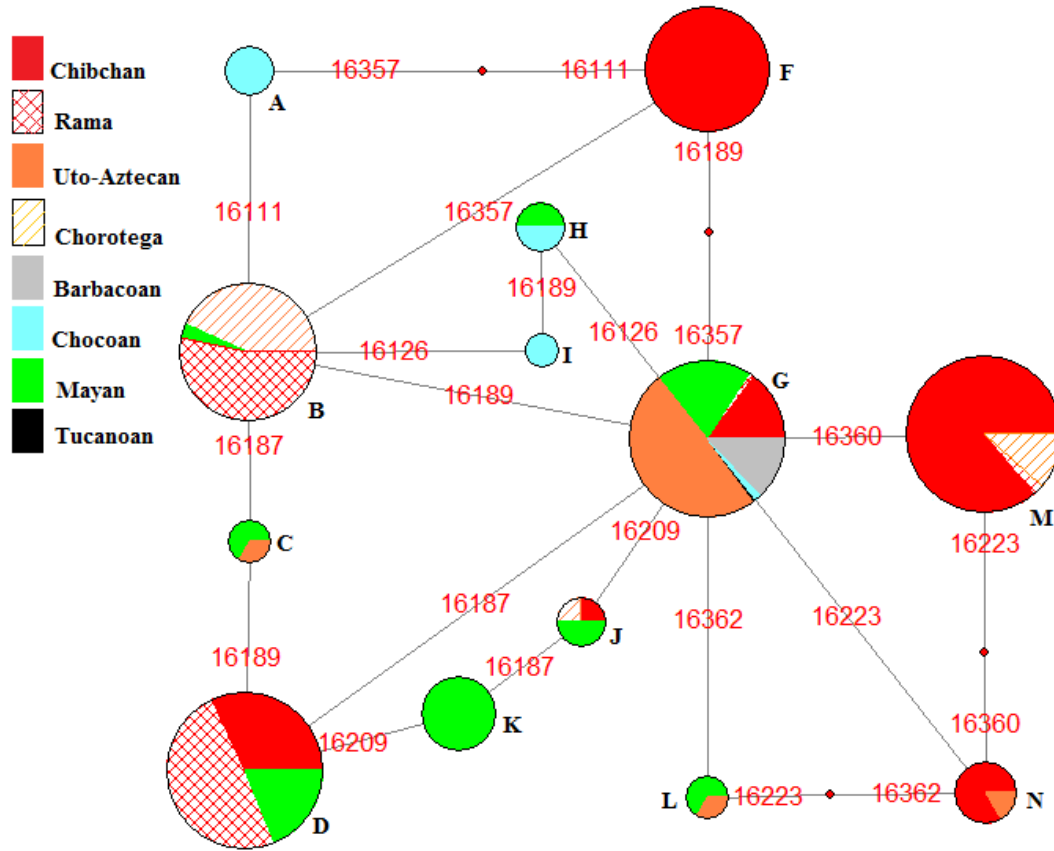

Figure 53. Reduced median network of Haplogroup A2 and associated linguistic families.

Table 43. Haplogroup A2 and associated nodes and populations from Mesoamerica and Central and South America.

Node	Associated populations	Node	Associated populations	Node	Associated populations	Node	Associated populations
A)	Wounan	F)	Arsario, Kogi	J)	Maleku, Chorotega, Poqomchi'	N)	Kuna, Otomi
B)	<b>Rama</b> , Chorotega, K'iche'	G)	<b>Rama</b> , Maleku, Guaymí, Poqomchi', Ch'orti', Cayapa, Ngöbé, Emberá, Wounan, Otomi, Mixtec, Maya, Triqui, Coreguaje	K)	Ch'orti', Poqomchi'		
C)	Ch'orti', Maya, Otomi	H)	Ch'orti', Emberá	L)	Mixtec, K'iche'		
D)	<b>Rama</b> , Guaymí, Ch'orti', Poqomchi', Ngöbé, Maya, K'iche'	I)	Emberá	M)	<b>Rama</b> , Huetar, Guaymí, Chorotega, Ngöbé		

Clades B and D are linked by nucleotide transitions 16189 and 16187, sharing sequences with K'iche', Ch'orti', Poqomchi', Chorotega, Ngöbé, Maya (K'iche'), and Guaymí. Clade M (np 16360), includes Rama, Ngöbé, Guaymí, Huetar, and Chorotega sequences. The estimated coalesce dates between the ancestral node G and descendant clades D, M, and B are roughly:  $6514 \pm 6514$  ( $\rho = 0.32$ ),  $3676 \pm 3676$  ( $\rho = 0.18$ ), and  $3246 \pm 3246$  ( $\rho = 0.16$ ).

Transition 16189 and 16111 shared by nodes A, F, and B includes Maya (K'iche'), Chibchans from Central and South America (Rama, Guaymí, Arsario, and Kogi) and the Chocoan (Wounan) implies that these populations have a common ancestor in the past. Based on

coalescent dates, node F splits early ( $4628 \pm 2314$ ,  $\rho = 0.22$ ) followed by node B at  $3246 \pm 3246$  ( $\rho = 0.16$ ).

The median joining network for haplogroup B2 is pictured in figure 54. The central node includes Chibchans (and the Rama), and Chocoan populations. The star-like phylogeny indicates population expansion due to the occurrence of more recent mutations.

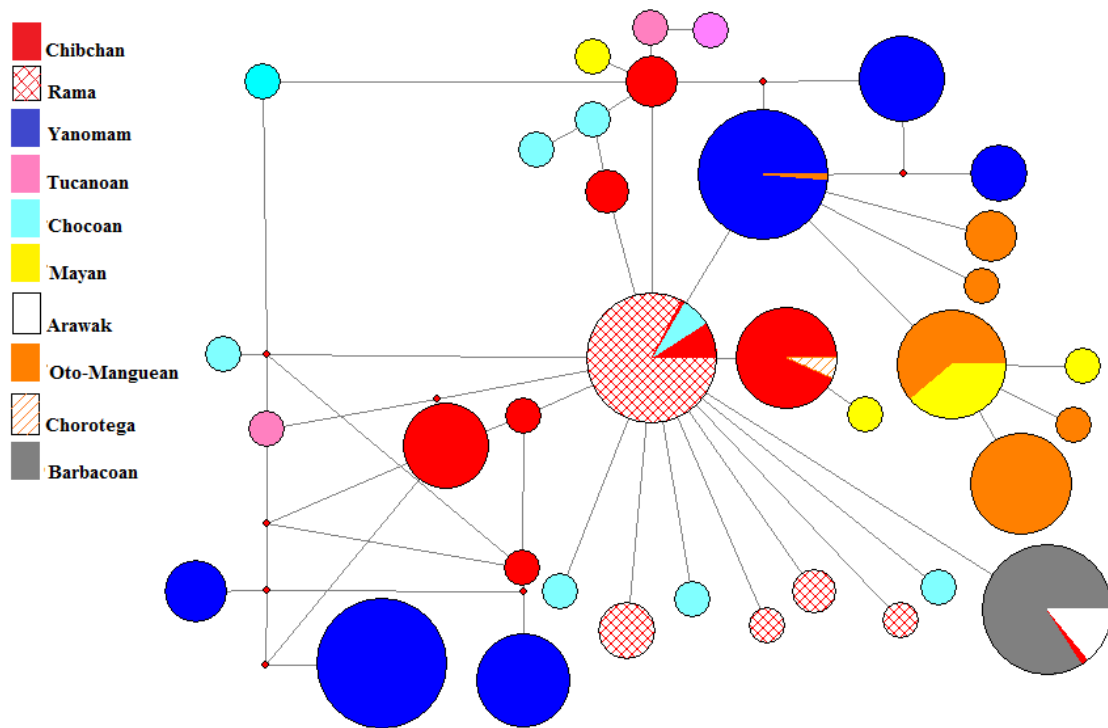

Figure 54. Median joined network of haplogroup B2 and associated linguistic families.

A network of haplogroup B2 was generated (Fig.55) excluding those populations that are not immediately linked to the Rama. The Rama, centered at np 16189 and 16217, appear to be the most ancient haplotype (central red), along with the Kuna, Emberá, and Huetar. These populations are also linked to the Huetar, Maleku, Guaymí, and Chorotega by transition 16217 and their coalescence might have happened around  $1811 \pm 1811$  ( $\rho = 0.08$ ) YBP. Additionally, np

16325 and 16223 links the Guaymí, the Ngöbé, and the Rama. Yanomamo, Otomi (np 16183) and Cajapa, Wayuu, and Ijka (np 16357) are also related to the central node, indicating their close relationship and its coalescence between  $7154 \pm 7154$  ( $\rho = 0.35$ ) and  $5780 \pm 5780$  ( $\rho = 0.28$ ) YBP respectively.

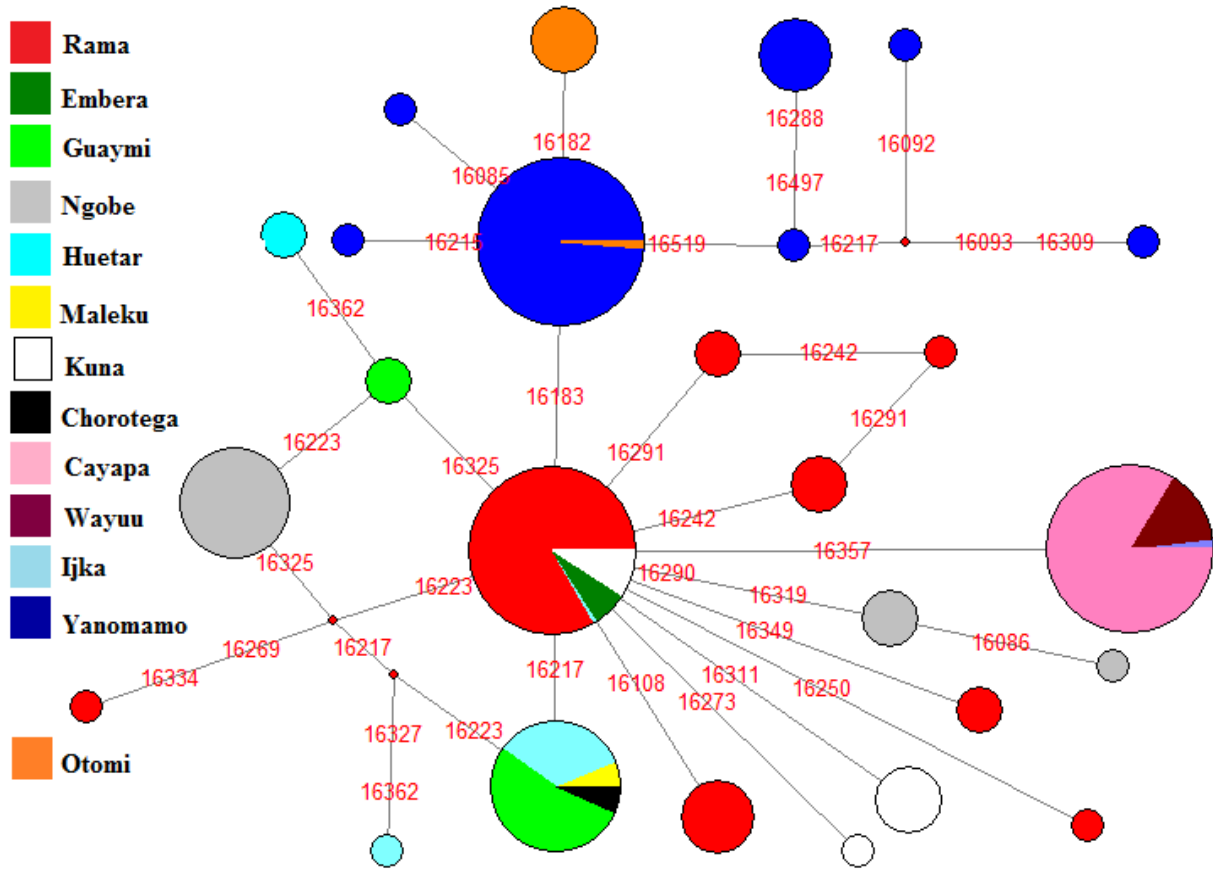

Figure 55. Phylogenetic network of associated B2 haplotypes from Central and South America.

The third haplotype network was constructed for the maternal lineage C1. Figure 56 and table 44 shows a network of individuals and reticulated haplotypes around node A that includes Yanomams (Yanomamo), Chocoans (Emberá and Wounan), and Arawak (Taino) speakers. Rama Amerindians are included in node O and separated by three mutations from the ancestral



node A and by two mutations (16327 and 16172) from the Taino in node N. According to this network, the most parsimonious relationship of the Rama C1 haplotype is with the Taino, an extinct population from Dominican Republic (Lalueza-Fox et al. 2001).

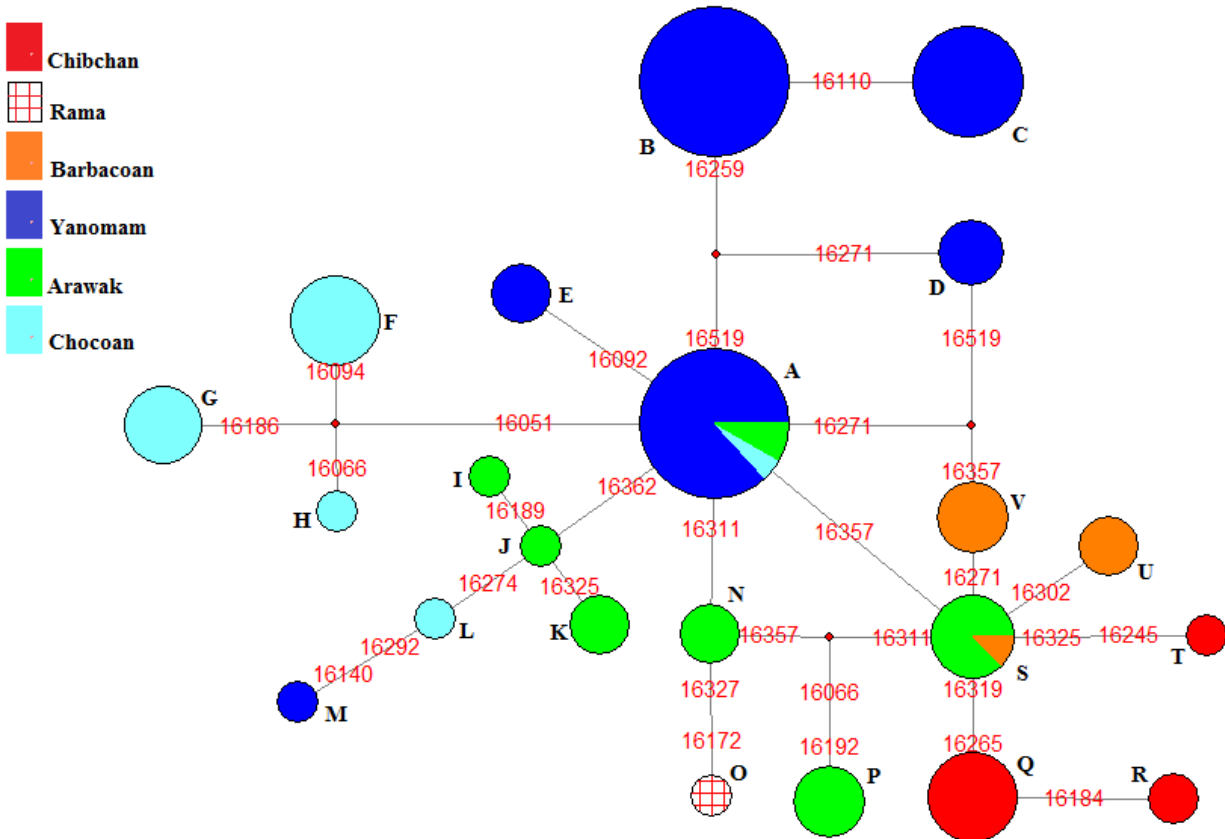

Figure 56. Reduced median network of Haplogroup C1 and associated linguistic families.

Coalescent dates for the Rama indicate that the haplotype in the associate node O occurs  $1729 \pm 576$  ( $\rho = 0.57$ ) YBP. Taking into consideration the standard deviation, this event might have happened around the year 305 (BCE) and 847 CE).

Table 44. Haplogroup C1 and associated nodes and populations from Central America, South America and the Caribbean.

Nodes	Associated populations	Nodes	Associated Populations	Nodes	Associated Populations
A)	Taino, Emberá, Wounan, Yanomamo	L, G)	Wounan	Q)	Arsario, Kogi
<b>O)</b>	<b>Rama</b>	B,C,D,E, M)	Yanomamo	R)	Arsario
<b>I,N)</b>	<b>Taino</b>	V,U)	Cayapa	F)	Emberá, Wounan
J)	Ciboney	S)	Cayapa, Wayuu	H)	Emberá
K)	Ciboney, Taino	P)	Wayuu	T)	Ijka

### Regional Barriers of Gene Flow

Figure 57 shows the results of the Monmonier's algorithm applied to Chibchan populations from Southern Central America and South America. The Oto-Manguean Chorotega was included in this analysis. The diagram depicts the relative geographic position of the populations and they are indicated by numbers. Populations are linked by vectors of interconnected points, the Delaunay triangulation encircled by Voronoï tessellations, or polygonal population boundaries.

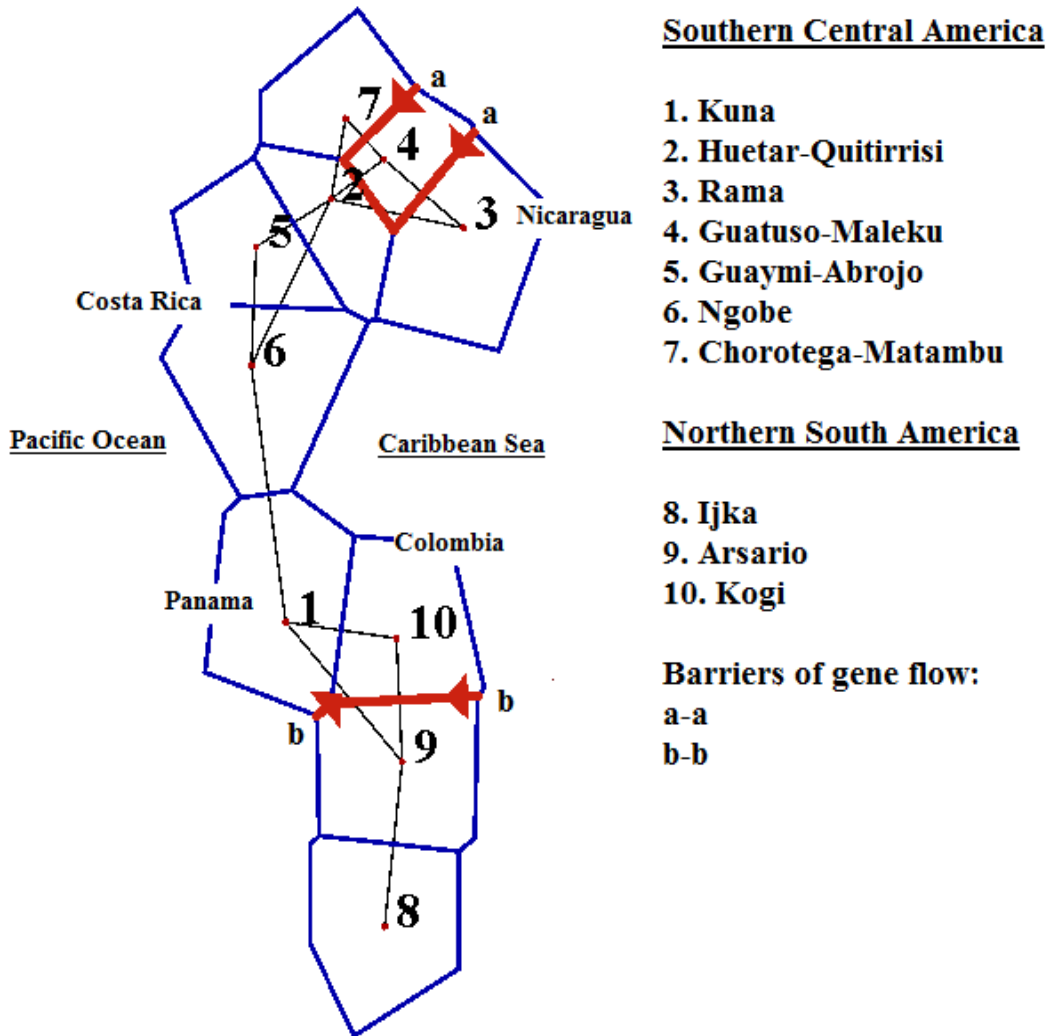

Figure 57. Delaunay triangulation (interconnecting lines), Voronoi tessellations (polygons), and genetic barriers (in red) of Chibchan populations.

The Votic speaking Guatuso-Maleku from northern Costa Rica is the most isolated population relative to the surrounding Chorotega, Huetar, and Rama. The first barrier (a-a) generated by the Monmonier's algorithm is the most robust compared to barrier (b-b). The genetic barrier of gene flow (a-a) is likely to be located somewhere between the Lake Nicaragua

(Cocibolca), Caño Negro in Costa Rica, and other associated wetlands of the San Juan River. This region, characterized by swamps and rain forests, might have reduced, in the ancient past, the interaction between populations during the Flandrian interglacial stage no later than 6000 YBP (Bergoing and Protti 2006). The second most robust barrier of gene flow was located somewhere between the Kogi and the Arsario from Colombia.

### **Regional Genetic Structure Based on AMOVA**

In order to determine whether population structure was present at different levels of population segregation, three hierarchical models were tested using mtDNA HVS-I sequences of 32 populations from Mesoamerica, Central America, and northern South America. The first group was based on four major geographical regions (Mesoamerica, Southern Central America, Northern South America, and the Caribbean). The second AMOVA was constructed based on 10 linguistic families (Oto-Manguean, Uto-Aztecan, Mayan, Tarascan, Chibchan, Chocoan, Arawak, Tucanoan, Yanomam, and Barbacoan). The third AMOVA was based on four major culture areas (Mesomerica, Isthmo-Colombian region, Amazonian region, and the Caribbean).

Table 45 presents the resulting AMOVA for geographical groupings. The amount of variation observed among groups is 11% ( $F_{ct} = 0.11$ ). The  $F_{ct}$  value indicates that there may be a maternal genetic differentiation among groups based on their geographic location, and 17% of the variation among populations is found between these groups ( $F_{sc} = 0.18$ ). The 72% of the remaining variation accounts for the variation within individual populations ( $F_{st} = 0.27$ ).

Table 45. AMOVA based on geographical grouping (Mesoamerica, Southern Central America, Northern South America, and the Caribbean).

Source of variation	D.F.	Sum of Squares	Variance components	Percentage of Variation	<i>F</i> -statistic	<i>P</i> -value
Among groups	3	557.856	0.42230	11	$F_{ct} = 0.1104$	< 0.001
Among populations between groups	28	902.581	0.63948	17	$F_{sc} = 0.1879$	< 0.001
Within populations	1506	4160.39	2.76255	72	$F_{st} = 0.2776$	< 0.001
Total	1537	5620.83	3.82433	100		

Based on linguistic affiliation, table 46 provides the fixation indexes and corresponding percentages of three hierarchical aggregations. The variation among linguistic stocks is 12% ( $F_{ct} = 0.12$ ), the variation among individual populations and between groups is 14.5% ( $F_{sc} = 0.16$ ), and within populations is 73.5% ( $F_{st} = 0.26$ ).

Table 46. AMOVA based on linguistic affiliation (Oto-Manguean, Uto-Aztecan, Mayan, Tarascan, Chibchan, Chocoan, Arawak, Tucanoan, Yanomam, and Barbacoan).

Source of variation	D.F.	Sum of Squares	Variance components	Percentage of Variation	<i>F</i> -statistic	<i>P</i> -value
Among groups	9	866.21	0.4522	12	$F_{ct} = 0.1203$	< 0.001
Among populations between groups	22	594.2	0.5442	14.5	$F_{sc} = 0.1645$	< 0.001
Within populations	1506	4160.39	2.7625	73.5	$F_{st} = 0.2650$	< 0.001
Total	1537	5620.83	3.7590	100		

Table 47 displays the results of the AMOVA based on Culture areas. According to this analysis, 14 % accounts for the variation among groups ( $F_{ct} = 0.14$ ) and 13.8 % is attributed

among populations and between cultural groups ( $F_{sc} = 0.16$ ). The variation between every individual population ( $F_{st}$ ) is 0.28.

Table 47. AMOVA based on four major cultural areas (Mesoamerica, Chibchan region, Amazonian region, and the Caribbean).

Source of variation	D.F.	Sum of Squares	Variance components	Percentage of Variation	$F$ -statistic	$P$ -value
Among groups	3	583.727	0.46866	14.4	$F_{ct} = 0.1436$	< 0.001
Among populations between groups	28	633.201	0.44903	13.8	$F_{sc} = 0.1607$	< 0.001
Within populations	1506	3531.58	2.34501	71.9	$F_{st} = 0.2812$	< 0.001
Total	1537	4748.51	3.26271	100		

The previous analyses demonstrate population structure based on cultural traditions more than linguistic stocks or geography. Mesoamericans, Chibchan, Amazonian, and Caribbean cultures, are segregated along maternal lines and within cultural subgroups. This interpretation is supported by the highly significant indexes of fixation among groups ( $F_{ct} = 0.14$ ,  $P < 0.001$ ), the genetic subdivision within individual cultural groups ( $F_{sc} = 0.16$ ,  $P < 0.001$ ), and within individual populations ( $F_{st} = 0.28$ ,  $P < 0.001$ ) and gives reasonable support to the possibility of genetic differentiation among cultural traditions based on the internal genetic variability of these groups.

### Genetic Chronometry

The method to estimate divergence time between populations (Reynolds et al. 1983b) was applied to the pairwise  $F_{st}$  genetic distances from mtDNA HVS-I sequences among Chibchan populations (Table 48). Looking at only significant values ( $P < 0.001$ ), this analysis

suggests that the divergence of the Chorotega, the Votic Rama and the Guatuso, from the Arsario, the Ijka and the Kogi occurred between roughly 9000 and 5000 YBP, then Central American Chibchans split between 4000 and 2000 YBP. Time estimates coincide with the Glottochronology of a proto-Chibchan linguistic ancestor that coalesced before 10,000 YBP and later split into four linguistic families (Lencan, Misumalpan, Payan, and Chibchan). This linguistic fragmentation may have occurred between 7000 and 6500 YBP (Constenla 2002a; Constenla 2005; Constenla 2008).

Table 48. Time estimates for Chibchan populations based on  $F_{st}$  genetic distances from mtDNA HVS-I.

	Kuna	Huetar	Rama	Guat.M	Guaymí	Ngöbé	Chorot.	Arsario	Ijka	Kogi
Kuna	0									
Huetar	827	0								
Rama	<b>3289**</b>	<b>3417**</b>	0							
Guat.M	<b>5660**</b>	<b>3748**</b>	<b>6257**</b>	0						
Guaymí	1467	237	<b>3177**</b>	<b>3341**</b>	0					
Ngöbé	<b>1744**</b>	595	<b>2279**</b>	<b>3268**</b>	340	0				
Chorot.	<b>2251**</b>	377	<b>4200**</b>	<b>5138**</b>	467	803	0			
Arsario	<b>3087**</b>	<b>1501**</b>	<b>4889**</b>	<b>5007**</b>	<b>1380**</b>	1419	1267	0		
Ijka	<b>5408**</b>	<b>3160**</b>	<b>7210**</b>	<b>8814**</b>	<b>3099**</b>	3431	<b>4067**</b>	<b>2218**</b>	0	
Kogi	<b>3220**</b>	1287	<b>4590**</b>	<b>5761**</b>	1107	1225	487	112	3,415	0

\*\*= $P < 0.001$

## SUMMARY

This chapter examines vital events, evaluates health, approximates the demographic composition and the surname structure, infers marital behavior based on genealogical analyses, and provides the results for mtDNA RFLP and HVS-I sequences and classical genetic polymorphisms of the Rama.

Based on the maternal genetic lineages and RFLP analysis, this population is characterized by higher frequencies of the haplogroups A2 and B2 and two other less frequent

lineages (C1 and L3). mtDNA lineages demonstrate that the Rama cluster with other Chibchan speakers from SCA and South America and show signals of genetic drift for most of their genetic history, however, a more recent population expansion and gene flow is likely to be associated with historical events after the European colonization to the Caribbean region, as well as with the effect of population pressure caused by new immigrants in recent decades. These events are also correlated with health status and causes of mortality among the Rama.

The analyses also demonstrate that two groups of communities are subdivided on central and peripheral clusters. This pattern was inferred based on mtDNA variation, surname structure, and a phylogeographic analysis.



## VI – DISCUSSION

This chapter aligns the results presented in chapter five with the objectives of this study within a broad context of molecular, archeological, ethnohistorical, and personal ethnographic observations from the field. Sections included in this chapter focus on: 1. the ethnogenesis of the Rama by comparing it with the regional genetic geography, 2. the forces of evolution impacting this population, 3. the consequences of recent historical events, social structure, and migration on the genetic architecture of the Rama, 4. the effect of culture and the environment on the bio-demographic structure of the Rama, and 5. the correspondence between linguistic, ethnohistorical, and archeological information within the history of the Rama.

### ***GENETIC RELATIONS AND ETHNOGENESIS OF THE RAMA AMERINDIANS***

#### **Mitochondrial Diversity**

The information provided by the mtDNA opens a new avenue for interpretation of the origin of the Rama Amerindians as this marker retains maternal sequential records of the accumulation of genetic diversity through time (Underhill and Kivisild 2007). Mitochondrial DNA haplogroups within the Rama belong to three (A2, B2, and C1) of the four major founding macro haplogroups (A2, B2, C1, and D1) in the Americas (Torroni et al. 1993; Wallace and Torroni 1992), as well as the African haplogroup L3. These results differ from the previous research carried out among the Rama by Melton (2008) due to the presence of two new haplogroups (C1 and L3). By augmenting the sample size by visiting four additional villages (Zompopera, Indian River, Greytown, and Punta Aguila), the haplogroup percentages also

changed (B2 = 71%, A2 = 28%, C1b = < 1%, and L3 < 1%). Despite these new incorporations, haplogroup B2 is still the most frequent among the Rama.

To date, the Rama is the only indigenous population that exhibits higher frequencies of haplogroup B2 when compared to other Central American Chibchan speakers, Mesoamericans (except the Necostla from Mexico), and Caribbean groups (Batista et al. 1995; Boles et al. 1995; Hunley and Healy 2011; Justice 2011; Kolman and Bermingham 1997; Kolman et al. 1995; Lalueza-Fox et al. 2003; Lalueza-Fox et al. 2001; Melton 2008; Melton et al. 2007; Merriwether et al. 2000; Perego et al. 2012; Sandoval et al. 2009; Santos et al. 1994; Tamm et al. 2007). In Colombia, the Guane-Butaregua, the Emberá, the Waunana, the Yuko-Yukpa, the Venezuelan Shamatari, as well as the Cayapa from Ecuador (Keyeux et al. 2002; Rickards et al. 1999; Williams et al. 2002) also exhibit high frequencies of haplogroup B2.

The most common B2 haplotype among the Rama is CA8 (np 16189, 16217), a phylogeny shared with other SCA groups (Kuna, Emberá, and Huetar). Despite the ancient relationship between the Rama and Central American populations, other Rama phylogenies evolved independently. Given the time frame generated by the molecular clock, it is likely that the coalescence of Central American and other northern South American populations from the most ancient phylogeny, B2, occurred ~7000 YBP or earlier, when the Chibchan Ijka, the Arawak Wayuu from Colombia, and Yanomamo from Venezuela separated from the aforementioned Central American Chibchans. In addition, the most recent of the Rama B2 haplotypes coalesced around 4000 YBP. It is worth mentioning that the Rama and other northern Costa Rican populations such as the Chorotega, the Huetar, and the Maleku, coalesced at approximately the same time. After this event, recent genetic variants appear in the B2 lineage among the Rama. Most of these new variants were dated to historical times, around 1700 CE.

This date correlates with the relocation in the 18<sup>th</sup> century of a group of Rama Amerindians from the San Juan River refuge to the area between Monkey Point and Punta Gorda that was already occupied by a fraction of them (Incer and Perez-Valle 1999; Kemble 1884a; Schnaider 1989). Gene flow mainly between Rama subgroups and within the San Juan River refuge might explain the high frequency of B2 haplotypes in their gene pool (CA8, CA9, CA10, CA11, CA19, CA20, CA23, CA24, and CA25).

The second most common haplotype of haplogroup A2 is CA4, (np 16111, 16187, 16223, 16290, 16319, 16362). This haplotype is shared by other Central American Chibchans (Maleku, Guaymí, and Ngöbé), with Mesoamerican populations (Poqomchi', Ch'orti', Otomi, Maya, Triqui, and Mixtec), and with non-Chibchan speakers from South America (Cayapa, Emberá, Wounan, and Coreguaje). This ancestral phylogeny indicates a common ancient origin of these groups. Derived phylogenies link the Rama with Mayan populations (Poqomchi', K'iche', and Maya from Santa Cruz), with Chibchans from Costa Rica (Huetar, Ngöbé, and Guaymí), and with the Oto-Manguean Chorotega. The Rama are also linked by one nucleotide difference (np 16357) to the South American Chibchan Arsario and Kogi. According to the molecular clock, the ancestral phylogeny that merges proto-Chibchans and proto-Mesoamericans most likely coalesced between 13,000 and 6500 YBP (~ 10,000 YBP). The subsequent separation of the Rama from other Central American Chibchans might have occurred between 7000 and 3000 YBP (~ 3500 YBP). Coalescent time estimates for haplogroup A2 and B2 yield consistent dates and are in agreement with historical accounts and ongoing genetic, linguistic, and archeological studies in SCA. (Baldi 2011; Barrantes et al. 1982; Constenla 1995; Hoopes and Fonseca 2003; Incer and Perez-Valle 1999; Kolman and Bermingham 1997; Loveland 1975; Melton et al. 2013; Melton et al. 2007; Romero 1995).

Haplogroup C1 is more common in South America and the Caribbean than in North America (Schurr 2010). In Mesoamerica, frequencies of this haplogroup are interspersed across disparate populations (Justice 2011; Sandoval et al. 2009). The Rama C1 haplotype includes transitions 16311, 16172, 16223, 16298, 16325, and 16327 and is separated by only one mutation (16172) from the ancient Taino (Lalueza-Fox et al. 2001). This finding opens the possibility of alternative scenarios of gene flow or genetic drift in SCA. The first possibility is the presence of this or closely related haplotypes, either from Central or South America, within the Chibchan gene pool (including the Rama) and subsequent loss or reduction through genetic drift (see Melton et al. 2007). To date, two studies have reported subclades C1c and C1d among Chibchans from Panama (Kolman and Bermingham 1997; Perego et al. 2012). In Colombia, Tamm et al. (2007) identified the subclades C4c (Ijka), C1c (Arsario), C1c and C1b (Kogi and Wayuu), and C1b was identified in Puerto Rico (Martinez-Cruzado 2010; Martínez-Cruzado et al. 2005), however, most of these sub-clades correspond to a much higher resolution analyses on complete mtDNA sequences, and are therefore not yet suited for comparison. The second possibility is that the C1 haplotype was introduced as a result of an exogamic marriage with Nicaraguan Mestizo or Black Carib (Garifuna) females; however, in a recent genetic survey in Nicaragua, haplotype C1 was absent (Nuñez et al. 2010) and among the Garifuna this haplotype clusters with South American populations (Salas et al. 2005). The last possibility is that C1 was introduced within the Rama gene pool by gene flow from the Greater Antilles. Within the Rama haplotype, C1 is only a one step derivative mutation from the ancient Arawak of the Dominican Republic (Lalueza-Fox et al. 2001). This gain of one mutation may have occurred between 305 BCE and 847 CE and according to the mutational expectation of the mtDNA locus. This scenario is plausible since inter-oceanic networks have been successfully modeled for pre-

Columbian times in the Circum-Caribbean region (Callaghan 2003; Callaghan 2008; Callaghan and Bray 2007; Rodriguez Ramos and Hofman 2009), and the exchange of exotic goods, stylistic resemblance of artifacts, microscopic traces of plants, isotopic analysis of human remains, and petrological and mineralogical signatures have been documented as evidence of contacts across said region (Geurdz 2011; Hofman et al. 2010; Olivier 2011). For example, exotic materials with iconographic representations associated with the Huecoid/Huecan Salaloid ceramics (500 BCE and 700 CE) in the Lesser Antilles and Puerto Rico have been ascribed to Costa Rica and Panama. This scenario of gene flow from the Caribbean to SCA should be approached with caution, however, after augmenting the sample size from the coast of Central America and having better molecular resolution, haplogroup C1 may prove to be a product of a late pre-Columbian intrusion within the Rama gene pool and not a result of genetic drift. Further genetic studies are needed to test Kolman and Bermingham's (1997) hypothesis of the absence of this haplogroup throughout most of the genetic history of the Chibchan populations.

Haplogroup L3 is indicative of a recent African mixture with the Rama. Africans intermarried with some Miskito Amerindians at Cape Gracias a Dios in the extreme north of Nicaragua early in 1641 when a shipwrecked slave ship left a number of Africans on the coast (Offen 2002). This population, named Sambo-Miskito, spread north and south along the Caribbean coast of Nicaragua in only a few generations (Hall and Perez-Brignoli 2003). With the beginning of the British rule (1695-1850), permanent settlements along the coast increased as a result of the importation of slaves from western and central Africa and migration from the Antilles. Culturally and linguistically recognized as a group during the 18<sup>th</sup> century, the Creole (or Kriol) is the intermixed population resulting from these diasporas (Holm 1978). The Miskito and the Creole of African ancestry are the population most likely to have, through intermarriage

with Rama males, introduced the L3 haplotype to the Rama. The gene flow between individuals of African ancestry and the Rama was probably recent (Battistuzzi et al. 1986) and it is more common at Rama Cay, Punta Aguila, and Greytown compared to any other Rama community according to admixture estimations obtained from surname analysis in this investigation and the results of a recent demographic survey (GTR-K 2007).

### **Regional Genetic Geography**

Based on glottochronology and lexicostatistics, the linguist Adolfo Constenla proposed the coalescence of a proto Lencan, Misumalpan and Chibchan linguistic stock around 10,000 YBP in SCA followed by the fragmentation and geographic isolation of Chibchan speakers including the Rama between 7000 and 6000 YBP (Constenla 2005; Constenla 2008). Constenla expected that an ancient proto-Chibchan linguistic nucleus might have existed between southern Costa Rica and western Panama due to the greater diversity of Chibchan languages found in this region (Constenla 1991; Constenla 1995). He also proposed that the Rama, the Corobicí, the Guatuso, and possibly the Huetar from northern and central Costa Rica, belong to the Votic sub linguistic family (Constenla 1991; Constenla 1994; Constenla 1995; Constenla 2002a). The spatial proximity and cultural affinity of these groups, along with the Chorotega, who inhabited the occidental region of northern Costa Rica, leaves open the possibility of relationships between them (Johnson 1948; Lothrop 1926; Riverstone 2004); however, such relationships are not fully understood and deserved attention in this investigation. It is generally accepted that the Chorotega-Mangue, descendants of Mesoamerican migrations from the Mexican highlands, arrived on the Nicoya peninsula in Costa Rica as a result of population pressure caused by the Nicarao and other Mesoamerican populations from the Pacific of Nicaragua in the 8<sup>th</sup> century (Fernandez de Oviedo 1959 [1535-1557 and 1851-1855]; Lothrop 1926; Torquemada 1975

[1615]). However, it is still unclear if these migrants replaced local Chibchan residents together with their social structures and cultural practices (Salgado and Fernandez-Leon 2011), or whether this migration of Mesoamericans only represents a partial replacement of the Chibchan (McCafferty 2008). B2 mtDNA lineages found in common between the Chorotega and the Votic Rama, Maleku, and Huetar precede Mesoamerican migrations when females of Chibchan ancestry intermarried with males of Mesoamerica origin at Gran Nicoya, suggesting their common ancestry (Melton 2008). This interpretation helps to explain the hybridization of Chibchan and Mesoamerican cultural traits found in the archeological record after the Tempisque Period (500 BCE - 300 CE) in Costa Rica (Baudez and Coe 1962; Guerrero and Solís 1997; Lange et al. 1991; Snarskis 1981; Sweeney 1976) and provides additional elements that suggest the persistence of social structures based on matrilineal residence, a distinctive characteristic in most Chibchan groups (Kolman and Bermingham 1997). Coupled with this interpretation, the admixture with resident Chibchan populations at the Gran Nicoya ~1000 CE may have happened after A2 lineages, shared by Mesoamerican (Ch'orti', Poqomchi', Maya, and K'iche') and Chibchan (Rama, Maleku), split early from their source population between 10,000 and 7000 YBP, possibly due to changes in environmental conditions between 12,000 and 10,000 YBP that produced an important switch in the flora and fauna and landscape evolution in SCA.

A warmer and wetter climate couple with the rise of the sea level after 10,500 YBP as well as the stabilization of marine coasts around 7000 YBP provided the necessary ecological conditions for the colonization of wetland forests in SCA (Cooke et al. 2013; Cooke and Ranere 1992a; Leyden 1995; Piperno and Pearsall 1998), The wetlands between Lake Nicaragua and the southern Caribbean coast might have significantly reduced the gene flow between Votic populations and other Mesoamericans, and Central and South American Chibchans. It is

estimated that this fission and rapid isolation might have occurred around 7000 YBP. The second division among Isthmic Chibchans from southern Costa Rica and Panama occurred with the onset of sedentarism and agriculture around 4000 YBP. Evidence of a genetic discontinuity between Votic populations and Mesoamericans has been modeled in this investigation using the Monmonier algorithm (Fig.57). This analysis yielded congruent results to two previous studies and placed the physical barrier of gene flow between Caño Negro in Costa Rica and alongside the San Juan River, the Nicaraguan Lake (Cocibolca), and the Caribbean coast around 7000 YBP (Justice 2011; Melton 2008). More so than today, in the past, this region was characterized by vast wetlands that may have reduced contacts between populations during the Flandrian interglacial stage before 6000 YBP (Bergoening and Protti 2006).

Optimal foraging theory has been applied to the region to suggest that hunter gatherers adapted to two main biomes: first to the more fit region for human habitation on the Pacific side of SCA, and later to the less favorable Caribbean lowlands (Piperno 2006a; Piperno 2011; Piperno and Pearsall 1998). However, this proposal contrasts with recent archaeological evidence found in the Caribbean region. For decades, this notion that the Caribbean was “less fitted” for human habitation and functioned as a receptacle of migrations and cultural influences from the Pacific side of Central America, Mesoamerica or South America was reproduced mainly by archaeologists and historians (Clemente et al. 2007; Drolet 1980; Gabb 1883; Gassiot and Estévez 2004; Griggs 2005; Ibarra 2011a; Linares and Ranere 1980; Linné 1929; Magnus 1974; Magnus 1978; Smutko 1988; Stirling and Stirling 1964; Stone 1972; Stone 1984); on the contrary, genetic information provided by this and previous studies (Baldi et al. 2008; Melton 2008) suggests that the Caribbean region of SCA was an important space for human microevolution and adaptation towards wetlands and coastal environments.



Recent archeological research has suggested associations of stone tools and organic matter yielding carbon dates of ~12,000 YBP in the Caribbean lowlands of Costa Rica (Chávez 2013). This, together with other Paleoindian reports from Costa Rica and Panama (Cooke 2005; Leon 2007; Pearson 2003; Snarskis 1979), suggests that human populations were already manipulating lowland environments earlier than previously thought. Although the rise of sea levels in the Holocene may have submerged a number of coastal Pleistocene sites (Cooke 2005; Thompson and Worth 2011), unconfirmed carbon dates of 7500 YBP from the Monkey Point Shell Midden constitute the earliest evidence of coastal adaptations in Nicaragua (Riverstone 2004) and the preponderance of sites containing evidence of coastal exploitation in southern Nicaragua has been dated after ~3000 YBP (Gassiot and Estévez 2004).

According to Cooke (2005), a signature of greater cultural complexity emerged in SCA around 6000 YBP when cultural provinces began to differentiate in Costa Rica and Panama. In addition, Baldi (2011), using multivariate statistical methods on ceramic styles, found divergent traditions between southern, central, and northern Costa Rica after ~4000 YBP. The time estimation of this event overlaps with the linguistic divergence of Central American Chibchans proposed by Constenla (1995) and with coalescent dates estimated by this study, however, Chibchan languages that belong to the Votic sub linguistic clade do not fit the principle of linguistic variation as a function of geographic distance. Votic speakers (Rama, Guatuso) share more grammatical and phonological elements with Magdalenic Chibchans from Colombia (Chimila, Kogi, Damana, Ijka, Muisca, and Bari) and the Pech (Paya) from Honduras than with geographically close Isthmic speakers. The Rama, the Guatuso, and the Pech along with the Chimila, Kogi, Ijka, and Bari incorporate noun prefixes in their language structure (e.g., first person: Guatuso: *na-*, Chimila: *na-*, Kogi: *na-~la-*, Damana: *ni*, Ijka: *nə-*, Bari: *da-*) (Constenla

2008). Cavalli-Sforza and Wang (1986) proposed that when two linguistic or cultural groups diverge from a common ancestor, they become less similar with the passage of time and are less likely to resemble one another. This especially true when cultural and linguistic inheritance is passed through a mechanism called vertical transmission (from parents to children through many generations). The same principle of linguistic diversity as a function of distance is applied to genetic diversity. In genetics this relationship is conceptualized by the isolation by distance model (Wright 1943).

One possible explanation for the grammatical similarities retained between the Chibchan Votic (Rama, and Guatuso) and the Magdalenic may be their early divergence and rapid isolation in the transition to the Holocene epoch. Based on the average number of mutations present in the mtDNA HVS-I segment, this separation most likely occurred at the beginning of the Holocene era (~ 9000 - 6500 YBP). The Rama and Chorotega are separated by only one mutational step (16357) in haplotype A2 from the Kogi and the Arsario from Colombia, thus a close genetic relationship can be established between these populations at this locus. Could it be possible that these populations split and moved more than a thousand kilometers away, between northern Costa Rica and the Santa Marta region in Colombia, at the beginning of the Holocene? Recent lines of evidence point out that coasts were important regions for human subsistence and movement of populations into new areas in the past 10,000 years (Torben and Erlandson 2009). Compelling evidence of sea voyages since the late Pleistocene has been documented in a great number of archaeological sites around world. In the Americas, one of the first indications of seafaring comes from the Bay Islands in California between ~12,200 and 11,200 YBP (Erlandson 2002; Erlandson et al. 2011). Seafaring across the Caribbean and between islands is supported by computer simulations of trans-Caribbean voyages as early as 8000 YBP (Callaghan

2003; Callaghan 2008; Callaghan and Bray 2007; Wilson et al. 1998). According to Callaghan (2003), Pre-ceramic cultures dating to between 6000 and 4000 YBP in the Greater Antilles such as Cuba, Hispaniola, and possibly Puerto Rico, may have originated in northern South America, northern Central America and southern Florida when continental areas, now submerged, were exposed and oceans were shallower. In addition, simulations demonstrated the feasibility of year round intentional or unintentional pre-Columbian voyages between the Tairona region in Colombia and northern Costa Rica and vice versa (Callaghan and Bray 2007). Given this evidence, it is possible that early migrations through the exposed coasts between SCA and northern South America by sea or on foot occurred in the late Pleistocene and early Holocene. If an early Chibchan migration from a presumed isthmian homeland occurred by coastal or open sea travels, then the rapid separation and isolation of Votic and Magdalenic speakers will explain their linguistic and genetic affinity. However, this would be only a partial explanation since only the maternal genetic history was examined in this investigation. In the future, supplementary NRY studies and sampling of additional Central American and Northern South American Native populations will be necessary in order to understand the paternal genetic history of the Chibchans. Figure 58 presents the coalescent model of genetics and linguistics of Chibchan speaker populations. This heuristic model was constructed based on the genetic information provided in this dissertation and on linguistic relationships taken from Constenla (2002b; 2005; 2008).

Contrary to the hypothesis sustained here, a recent, large study by Reich et al. (2012) compared 52 Native American and 17 Siberian groups using 364,470 single nucleotide polymorphisms (SNPs) and proposed that Chibchan-speakers inherit most of their genetic material from South American ancestors such as the Quechua. When Chibchans branched off

from their South American ancestors, they acquired the Mesoamerican genetic component through admixture during back-migration to SCA. One of the problems with this model is that it fails to explain the Mesoamerican component in South American Chibchans, and do not take into account important historical events such as the forced transplantation of thousands of Amerindians from Central America as slave commodities to places such as Peru in the 16<sup>th</sup> century (Denevan 1976b; Radell 1976). For this reason, the authors leave open an alternative scenario in which the Mesoamerican-related lineages “detected in Chibchan speakers reflect earlier admixture events between North and South American lineages, which are shared in the history of all Chibchan-speakers” (Reich et al. 2012, supplementary materials). However, this last scenario was already proposed and tested by previous research in the region (Baldi and Melton 2010; Baldi et al. 2008; Melton et al. 2013; Melton 2008; Melton et al. 2007) and continues to be a matter of scrutiny in this investigation.

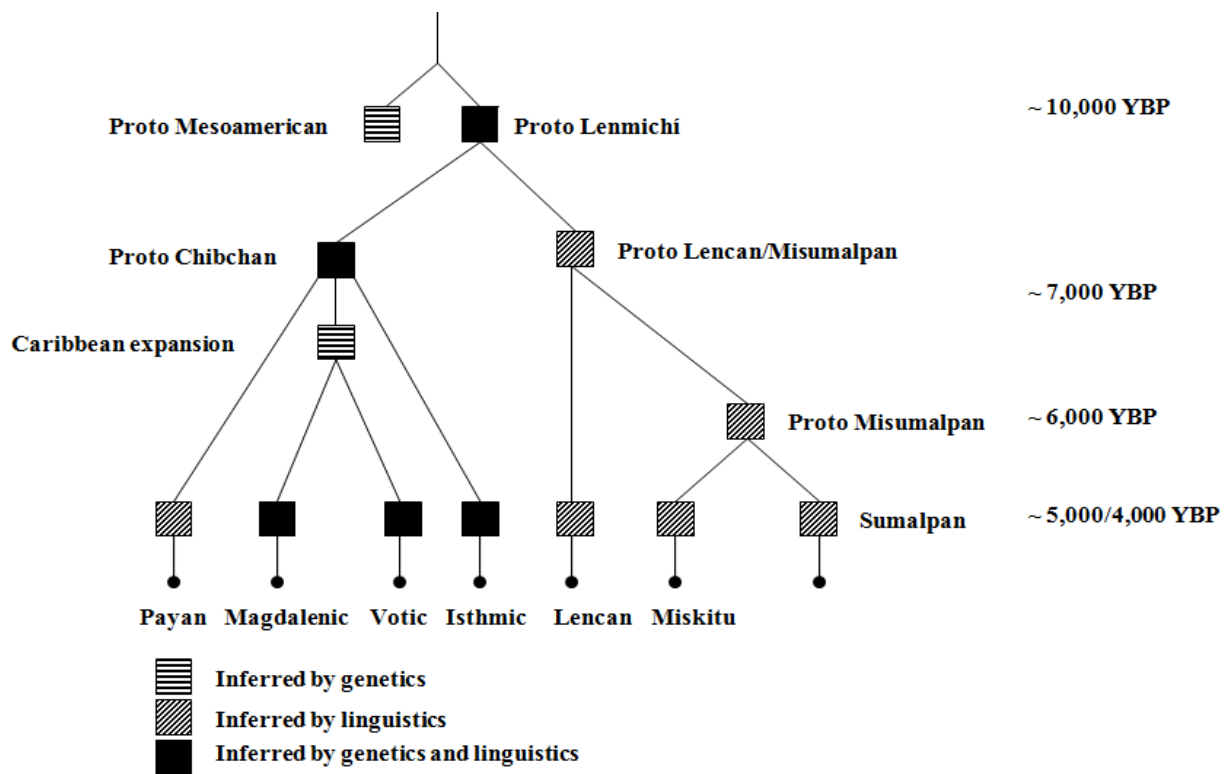

Figure 58. Heuristic model based on the coalescence on mtDNA and historical linguistics.

## ***GENETIC STRUCTURE AND FORCES OF EVOLUTION***

Contrary to the higher levels of admixture with Mesoamerican and European populations of the Rama and other Votic-speaking populations shown in the paternal line (Melton 2008; Melton et al. 2010), the regression of gene diversity (heterozygosity) versus  $r_{ii}$  using classical genetic markers demonstrated that most of the Chibchan populations experienced maternal genetic isolation compared to Mesoamericans and non-Chibchan from South America. Based on mtDNA, the interpretation of isolation and genetic drift of the Chibchans is also supported by previous investigations (Justice 2011; Melton 2008).

The MDS based on mtDNA sequences reveal a consistent partition of four groups of populations based on linguistic affinity, culture area, and geographic location: Chibchans, Caribbean, non-Chibchans from South America, and Mesoamericans. Because ancestral SCA Chibchans and Mayans coalesced at the beginning of the Holocene, the partial overlap of these groups was expected in the MDS,  $R$ -matrix diagrams, and neighbor joining trees. The proposed ancestral relationship between Chibchan and Mesoamerican populations is supported by this research and by two previous studies (Melton 2008; Reich et al. 2012) and contrasts with Justice's (2011) interpretation of the lack of such relationship.

Contrary to reiterated claims of the absence of correlation between culture, geography, and genetics in SCA (Ibarra and Salgado 2010; Salgado and Fernandez-Leon 2011; Salgado and Vasquez 2006), AMOVA tests of the hypothesized Chibchan genetic structure provided additional evidence to assert that the genetic maternal structure of the Chibchans exists primarily due to culture ( $F_{ct} = 0.14$ ,  $P < 0.001$ ) and linguistic affiliation ( $F_{ct} = 0.12$ ,  $P < 0.001$ ) and is less dependent on geographic isolation ( $F_{ct} = 0.11$ ,  $P < 0.001$ ). A higher than expected  $F_{ct}$  index implies that maternal genetic differentiation among these groups may be due primarily to cultural

traditions. These results support the hypothesis of concomitant patterns of culture (cultural traditions), language (linguistic variations), and genetic structure (genetic segregation) among Chibchans (Batista et al. 1998; Constenla 1995; Cooke 2005; Hoopes and Fonseca 2003; Santos et al. 1994). Cultural and genetic patterns may have resulted from a number of combined factors such as climate change, migrations, and isolation (Melton 2008). The interactions of these factors are essential in order to understand the genetic history of the Rama within a broader context of SCA.

Although genetic drift is the evolutionary force acting on most Chibchan populations, the Rama show non-significant negative neutrality test values ( $F_s = -0.47$ ,  $D = -0.38$ ). In order to investigate more localized genetic signatures, two additional tests on haplogroups A2 and B2 and on the Rama subpopulations were undertaken. They yielded statistically significant negative values of Fu's  $F_s$ , indicating a recent population expansion. The haziness of the degree of significance of these tests can be attributed to the fact that recent expansions would not provide sufficient genetic variants in the HVS-I to generate significant values (Zlojutro et al. 2006), thus, Fu's  $F_s$  and Tajima's  $D$  are not sufficiently sensitive to detect drift or recent expansions in comparison with the analysis of pairwise differences (Kolman and Bermingham 1997) on which this study relies. The reduced amount of mtDNA diversity seen in Chibchan populations has been interpreted as a product of a small founding population that gave rise to the reproductively isolated groups in Central and South America. The mismatch analysis of a number of Chibchans (Arsario, Ijka, Kogi, Kuna, Kgobe, Huetar, Emberá, and Ngöbé) produced a multimodal distribution similar to that seen in the Rama. They share mutational peaks between 7 and 10 and secondary peaks between 0 and 2 nucleotide differences (Batista et al. 1998; Kolman and Bermingham 1997; Kolman et al. 1995; Melton et al. 2007). This pattern may reflect a recent

Chibchan expansion around 10,000 – 7000 YBP after a severe bottleneck early in the genetic history of this group (Batista et al. 1995; Melton et al. 2007). Due to the striking similitude of the mismatch shapes and time estimates between the Rama and other Chibchan groups, it is likely that the Rama reflect a similar population history. In addition, low values of genetic diversity could have resulted from enforcing endogamy and uxorilocal marriage customs and the reduction of maternal gene flow between populations. Thus, the low diversity is consistent with the interpretation of the reduced gene flow among Chibchan populations (Batista et al. 1998; Batista et al. 1995; Kolman and Bermingham 1997; Santos et al. 1994). Recent studies also show similar conclusions for the mtDNA; for example, Melton (2008), comparing 17 populations from Central and South America has shown reduced heterozygosity due to genetic drift and the geographic isolation of Chibchan populations from Central America between 10,000 and 8000 YBP. The Y-chromosome, on the other hand, has shown more diversity due to the influx of Mesoamerican genetic lineages and the European influence after the 16th century. In addition to this, geographic isolation played a key role in the occurrence or absence of rare genetic variants and the microevolution of distinct metabolic pathways resulting from adaptations to local foods (Arias et al. 1988a; Arias et al. 1988b; Barrantes et al. 1990; Petersen et al. 1991).

## ***EVOLUTIONARY CONSEQUENCES OF RECENT HISTORICAL EVENTS***

### **Genetic Architecture of the Rama**

A closer examination of the mismatch distribution for individual haplogroups A2 and B2 provides a reasonable indication that both lineages contributed in different ways to the underlying mismatch distribution of the Rama. Haplogroup A2 shows a more complex lineage history of expansion-drift-expansion compared to haplogroup B2, which shows only evidence of a recent expansion (Fig.44 and 45). The network analysis for haplogroup A2 reveals a star-like

phylogeny in which the most ancestral node is shared by only two communities, Punta Aguila and Rama Cay, and is linked to other haplotypes by missing nodes that may reflect their loss by a past population reduction, i.e drift. Contrary to this, the star-like shape of haplogroup B2 is characterized by a number of singletons that radiate from one large, central node, indicating recent population expansion (Fig.54 and 55).

Separate analyses based on genealogical information provided additional elements for interpreting the two different patterns given by haplogroups A2 and B2 because they permit the examination of very recent historical events such as migration and colonization. According to Fix (1999), these two demographic aspects play a fundamental role in human microevolution via the spreading of genetic variants (in this study, neutral variants). In human societies, genetic subdivision is not only caused by the effect of geographic distance and isolation (sensu: Wright 1943; 1951), it also depends on mating patterns as well as superstructural (e.g., economies, religion, and politics) and ecological factors (Fix 1999; 2004).

The correlation between geography and surname distribution based on three distance matrices (Lasker's *D*, Euclidian, and geographic location), demonstrates that kinship decreases exponentially with distance as predicted by Malecot's isolation by distance model. This suggests that individuals that share the same surname, and are thus theoretically biologically related, are not randomly distributed in the geographical space. However, it must be emphasized that communities are not totally isolated from each other and they are interconnected by complex networks that serve to maintain familial and social relationships across the territory. For example, Rama Cay served as the major "population hub" where a great number of individuals are born, marry their partner, and migrate out after establishing a family. Migration is usually to places where other relatives are already settled (in satellite communities), although the



connection with Rama Cay is not lost and families and individuals usually return for visits to relatives, holidays, funerals, or the services of the local clinic. The only exception to this rule is Punta Aguila, where an important number of individuals were born in communities (40%) such as Cane Creek, Torsuani River, Red Bank, and Wiring cay (see Table 26, Fig.30).

Surname diversity is also concordant with the degree of isolation computed using unbiased isonymy ( $I$ ), Fisher's alpha ( $\alpha$ ), kinship relationships ( $\Phi_{ii}$ ), and Lasker's coefficient of relationship within populations ( $R_i$ ). In general, the most populated communities —Greytown, Rama Cay, and Punta Aguila— are less isolated and receive the largest migratory influx of non-Rama males. According to the same analyses, the most geographically and biologically isolated populations are Zompopera, Sumu Kat, and Indian River. These last two communities can only be accessed by river, which requires two days of traveling by canoe or approximately ten hours in a motor boat. The Rama neighborhood (Punta Fria) in Bluefields appears to be genetically isolated; however, the sample size was small and statistically limited. Two mtDNA parameters were used to explore the genetic diversity of these populations: the number of variant sites between genetic sequences ( $\theta_s$ ), and their nucleotide diversity ( $\theta_\pi$ ). According to these parameters, Rama Cay and Greytown have the highest diversity compared to the rest of the communities. Punta Aguila and Sumu Kat have the lowest values relative to the other communities. It may be noted that surname and diversity parameters based on mtDNA provided a fairly concordant estimation of the isolation and gene diversity expected among different Rama communities.

Additional analyses present two other aspects of Rama mating structure including inbreeding estimates ( $F$ -statistics), and the detection of population substructure ( $RP$ ). These approaches complement one another and help to evaluate sampling errors caused by small

sample sizes (North and Crawford 1996).  $F_r$ , or the random component of inbreeding (analogous to  $F_{st}$ ), estimates the amount of inbreeding expected by chance within each community. In populations such as Indian River, Sumu Kat, and Bluefields, the probability (values between 0.030 and 0.067) that someone is closely related to another person was higher because there are few non-related potential mates from which to choose. These values also indicate large deviations from Hardy-Weinberg expectations, internal subdivisions, and genetic drift. These three communities show preference for interlineage marriages; however, this is more prominent in Punta Aguila and Greytown, followed by Bluefields and Indian River. Among all populations, Rama Cay and Sumu Kat are less internally subdivided because they present less aversion towards consanguineous marriages. This interpretation resulted from the obtained negative values of the random and non-random components of the repeated-pair approach.

Isonymy analysis proved to be consistent with patterns of internal migration based on marital ratios and genealogies between communities. Correlation values obtained using Lasker's coefficient of relationships between communities ( $R_{ib}$ ) suggests that communities are differentially connected through kinship to residential units of small population size (satellite populations). Two main kinship networks emerge from these correlations between populations. The first was established between the main peripheral communities (Rama Cay and Greytown) with other satellite populations that include Sumu Kat, Zompopera, Indian River and Bluefields ( $R_{ib}$ : 0.05 - 0.09), the second network correlates Punta Aguila (central population) with Bluefields ( $R_{ib}$ : 0.05).

As observed by Loveland (1975), kin-structured networks are established by long distances and by days of traveling along the coast and rivers (Figure 59). The exception to this pattern is Punta Aguila, where most individuals were born and stay within the community, or

come from Torsuani River, Red Bank, Wiring Cay, Monkey Point, Cane Creek, or Rama Cay. The differentiation of central and peripheral populations was tested using AMOVA and the Monmonier algorithm on mtDNA sequences. According to AMOVA, 9.5% ( $F_{ct} = 0.09$ ,  $P < 0.001$ ) accounts for most of the genetic variation among peripheral and central groups, while 87.2% ( $F_{st} = 0.13$ ,  $P < 0.001$ ) of the total genetic variation is explained within Rama communities. Congruent with AMOVA, the second analysis found a genetic barrier of gene flow that separates Punta Aguila from the remaining five Rama communities (Rama Cay, Sumu Kat, Indian River, Greytown, Zompopera, and Rama Cay). Geographically, this barrier is estimated between the Bluefields Lagoon and Punta Gorda River. The confirmation of the genetic difference between Punta Aguila and the peripheral Rama communities comes from the median networks and the *R*-matrix and MDS plots which show that in Punta Aguila, some A2 haplotypes are more frequent compared to peripheral communities. Based on these analyses, it is likely that affinal relationships based on kin might have deep historical roots that have persisted until the present. Marital practices, probably based on assortative mating, created consanguineal relationships and alliances that underlie the genetic structure of the Rama and may be maintained for generations, explaining the observed division between central or peripheral communities.

Additionally, surname analyses indicated that the degree of exogamous marriages among the most populated Rama communities is relative to their proximity to Mestizo and Creole communities and to the increased immigration from the Pacific side of Nicaragua after the 1970's.



Figure 59. Rama family members traveling by canoe (*dori*) from Greytown to Canta Gallo (Indian River). Rama residential mobility allows them to exploit different microenvironments and increase their alimentary security, maintain kin and social networks, and evade natural hazards and epidemics.

In Greytown, Rama Cay, and Punta Aguila, exogamous couples are more frequent among individuals of Creole, Miskito, and Spanish ancestry. This trend is comparable to the most recent census carried out in the Rama territory (GTR-K 2007) which indicated that exogamous relationships with Mestizo, Creole, and Miskito are more frequent. However, exogamous marriages are more likely to occur between Rama females with non-Rama males. Melton et al.

(2013) found that 50% of the Y-chromosome lineages were Native American (Q1a3a) whereas the remaining 50% was of Eurasian origin (R1b1b2, G2a2).

### **Kin Structure Migration and Historical Origins of the Rama**

In looking at differences in the spatial distribution of the mtDNA haplotypes together with historical events a noteworthy pattern emerges: first, some haplotypes are differentially distributed among Rama communities and haplotype distribution is consistent with the historical relocation of the Rama; second, differential genetic signatures found among Rama communities resemble different population histories; and third, kin structure migration (KSM) is the most parsimonious model for the genetic microdifferentiation of the Rama.

This investigation proposes a series of population movements that gave rise to the modern Rama (Fig.60). Based on the available ethnohistorical information, the home range of the Rama at the eve of the European colonization extended from the lowlands of northern Costa Rica, including the San Juan River, to the southern sector of Lake Nicaragua and from the southern Caribbean coast up to the Punta Gorda River region in Nicaragua. In the 16<sup>th</sup> and early 17<sup>th</sup> centuries, this region was an indigenous refuge from European colonization, sheltering the Rama and other populations from the European invasion that was initiated in the highlands of the central Caribbean of Costa Rica (Solorzano 2000; Solorzano and Fonseca 2006). The San Juan River refuge lasted until the 17<sup>th</sup> century, when it became a source of dispute between the Spanish and the British for access to Lake Nicaragua. The aggregation of different population at this refuge may have augmented the possibilities for gene flow between Rama sub-groups or with other groups such as the Nahua, who probably hived off from the Pacific side of Nicaragua in the 16<sup>th</sup> century (Torquemada 1975 [1615]). To demonstrate this possibility, Melton (2008) found closer genetic relationships between male lineages of the Rama and Mesoamerican

populations at the Y-chromosome level. The fusion of different Rama groups may be responsible for a population expansion and subsequent gene flow. This scenario is possible since lineages A2 and B2 found among the Rama share haplotypes with other Votic populations from northern-central Costa Rica (Guatuso-Maleku, and Huetar) and with the Matambu-Chorotega. Haplogroup B2 presents a striking star-like phylogeny where most of the descendent haplotypes coalesced in the 18<sup>th</sup> century (1700 CE). Due to the large standard deviations obtained in this estimation, this date can only be accepted as an approximation for the population explosion represented in this haplogroup during the time when the San Juan River functioned as an indigenous refuge. In addition, some A2 (CA5) and B2 (CA23) haplotypes appear to be related more with central groups and are less diffused among peripheral populations. This situation leads to the proposal that said haplotypes were restricted to maternal lineages in the Punta Gorda region (including Punta Aguila) due to reduced genetic flow with other peripheral groups.

The demographic information on the Rama gathered from pirates, merchants, ethnographers, missionaries, and others since the 18<sup>th</sup> century is contradictory and does not provide consistent figures through time. A dispersed settlement pattern and seasonal mobility along the rivers of southern Nicaragua obstructed demographic surveys. This problem persists today, even with better means of transportation (GTR-K 2007). A population growth occurred after the 1990's. Before this decade, dating back to the 19<sup>th</sup> century, the population fluctuated between 200 and 500 individuals according to imprecise data collected by different individuals (Bell 1862; Conzemius 1927; Grinevald 2003; Loveland 1975; Nietschmann and Nietschmann 1974; Roberts 1978 [1827]; Wickham 1872). These uncertain estimates allow for the speculation that the Rama population between the 19<sup>th</sup> century and the early 1980s was higher than previously thought. The reduction of the Rama population was principally caused by epidemics

brought by foreigners, particularly in the San Juan River region and less so in the Punta Gorda River, which was inhabited by a significant portion of the Rama in the 18<sup>th</sup> century (GTR-K 2007). Unfortunately, the number of fatalities caused by these events is for the most part undocumented in the ethnohistorical records. If the Rama population number was not dramatically diminished, then their reduced genetic diversity is likely to be the product of a small effective population size, social structure, and isolation. This can be further demonstrated by the similar shape that depicts the mismatch distribution of a number of Chibchan populations (see: Batista et al. 1998; Kolman and Bermingham 1997; Kolman et al. 1995; Melton et al. 2007). Historical estimates of population size indicate that the Rama were impacted negatively by European colonization, although the effect was less dramatic compared to the Pacific side of SCA where the Spanish presence was continuous since the 16<sup>th</sup> century, causing the reduction or the extinction of a number of native groups (Denevan 1976a; Hall and Perez-Brignoli 2003; Newson 1987). A combination of factors may have benefitted the survivorship of the Rama after centuries of European exploitation. For example, dispersed settlement patterns, residential mobility, and extended kin networks were established throughout a vast area of southern Nicaragua and the San Juan River region. In addition, the reduced capacity of the European mobility in the Caribbean wetlands might have decelerated the population decline of the Rama. This by no means minimizes the negative impact of European and other native groups (e.g., Miskito Amerindians) on this population, but demonstrates a different demographic impact in comparison with other populations in the region.

In order to escape slavery and the outbreak of diseases, in the second half of the 18<sup>th</sup> century the Rama from the San Juan River migrated to Punta Gorda in the northern region of their territory, an area inhabited by another faction of the Rama. Once established there, this

population intermittently migrated to other territories such as the Rio Indio on a number of occasions when escaping from pirates and Miskito Amerindians. In the 1780s Robert Hodgson was astonished at not finding Rama Amerindians in this river (Romero 1996); however, around four decades later, Orlando Roberts reported nearly 500 individuals between the San Juan River and Bluefields (Roberts 1978 [1827]). The short period of stability in the second half of the 19<sup>th</sup> century may have stimulated gene flow as groups of kin hived off from the San Juan River group and fused with the existent Rama community at Punta Gorda. This gene flow is likely among certain family lineages but not necessarily all of them. Once the Rama were established at Punta Gorda and other regions of southern Nicaragua, a new foreign colonization began, this time for the extraction of bananas, lumber, and other products in the late 18<sup>th</sup> until the early 20<sup>th</sup> century. This period marks the beginning of important changes in demography, culture, and genetic structure following the migration of some 200 Rama from Punta Gorda to the Bay of Bluefields (Hasemann et al. 1996), and in recent years, the re-colonization to their ancestral lands at the San Juan River and Rio Indio. According to Hasemann et al.(1996) the fission of these two groups from Punta Gorda was induced by internal conflicts, an interpretation corroborated by the Rama's myth of creation (Loveland 1975) that tells the history of their separation and relocation in the Bay of Bluefields (see Table 5).

This type of migration, known as kin-structured migration (KSM), is common among populations with high mobility (Fix 1999). According to Rogers (1987), family dispersion affects the population structure because it increases the genetic variation expected among groups. KSM is distinguished from a related phenomenon called "lineal effect"(Neel and Salzano 1967) in which the fission and fusion process occurs in short periods of time. According to Moon (1994) this practice is analogous to anastomosing river channels in which divergent populations can fuse



and exchange genes. This model contrasts with the traditional view of human population history as the branching off and isolation of daughter populations. In order to trace the population history of the migration of the Rama, the mtDNA was used because in theory this marker is not affected by natural selection, does not recombine, and its polymorphisms increase frequency by drift (Fix 2011). Similarly, KSM was observed by Barrantes (1993) among indigenous populations in Panama and Costa Rica when a variant of the Yanomamo's lineal effect was established among Guaymí groups that migrated to southern Costa Rica from Panama in the second half of the 20<sup>th</sup> century. Like the Rama, a pattern of fission-fusion in short periods of time caused a particular population structure and explains the high frequency of certain alleles.

Genetic signatures of mtDNA are differently distributed among all Rama communities and are concordant with the historical events discussed above and with KSM. The high frequency of specific A2 (CA5) and B2 (CA23) haplotypes are highly represented or are specific among the central population of Punta Aguila compared to peripheral groups. This may indicate their longer permanence (before 18<sup>th</sup> century) at the Punta Gorda region and low levels of gene flow with the Bay of Bluefields and Greytown communities. On the contrary, A2 (CA2, CA4, CA22) and B2 (CA8, CA9, CA10, CA11, CA19, CA20, CA24 and CA25) are only shared or are highly represented in peripheral communities (Table 37).

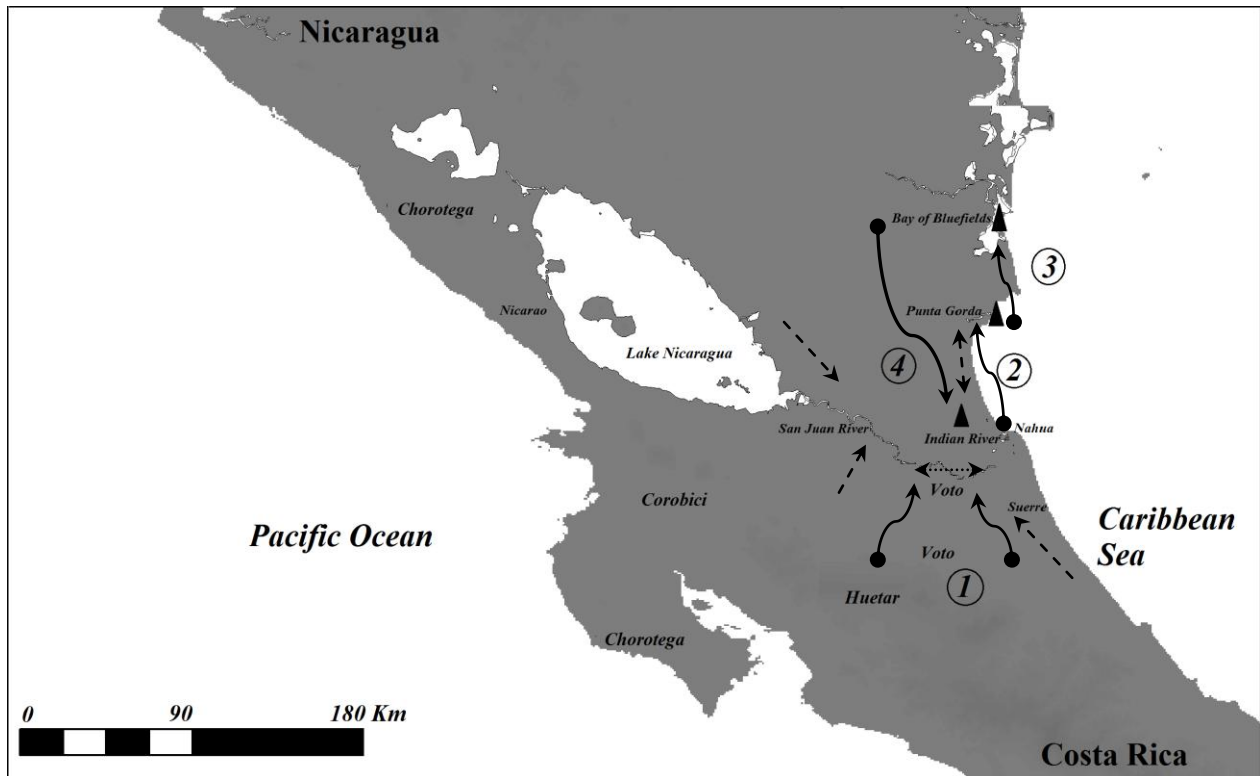

Figure 60. Migratory history of the Rama (Voto): (1) in the 16<sup>th</sup> and 17<sup>th</sup> century the San Juan River region functioned as a refuge for indigenous populations escaping European colonization in other regions of Costa Rica and likely Nicaragua. Dashed arrows indicate migrations of indigenous populations to the San Juan River region. The San Juan River and its tributaries was also a base for the Voto and a number of now extinct indigenous groups. The horizontal dotted arrow indicates possible gene flow between Voto maternal lineages due to KSM. It is likely that gene flow also occurred between the Voto and other indigenous groups. (2) The Voto, known as Rama in the 18<sup>th</sup> century, migrated out from the San Juan River region to Punta Gorda where another Rama faction, the “wild” Caribs, resided. In the same century, sporadic migrations from Punta Gorda and Indian River protected them against the outbreak of diseases and slave raids. (3) A fraction of the Rama relocated in the Bay of Bluefields and Rama Cay (Peripheral Group) at the end of the 18<sup>th</sup> century and early in the 19<sup>th</sup> century while another fraction of the Rama stayed in Punta Gorda (Central Group). The isolation of these two groups gives rise to dialectal variants, Rama Cay Creole and other Creole registers. (4) Overpopulation of Rama Cay and increased conflict and competition for land and marine resources induced migration and re-colonization in Southern Nicaragua and the Bay of Bluefields region in the late 20<sup>th</sup> century. Aggregation of the Rama in communities is a recent phenomenon resulting from the pressure for resources by foreign interests and Mestizo peasants.

The reduced gene flow between central and peripheral groups was corroborated through AMOVA, *R*-matrix, migration matrix, and the Monmonier algorithm. Family units that split off

from Punta Gorda and populated Rama Cay and areas near rivers and tributaries surrounding the Bay of Bluefields became partially isolated. However, in recent years the settlement pattern is changing.

### **Transition and Contemporary Dynamics of Kin Structure Migration**

After the 1970s, due to the expansion of the agriculture frontier and the influx of Mestizo migrants from the Pacific side of Nicaragua, family units were integrated into communities in order to avoid physical violence and the loss of their communal land. Contrary to the traditional isolated households, these communities represent new aggregations linked by networks to other communities that are separated by dozens or hundreds of kilometers. This change of settlement pattern had a consequential effect on population structure, health, and social dynamics. For example, Rama Cay, the most important population hub comprising half of the Rama population, is where most individuals were born, married their partner, and moved out with their families. Rama Cay is internally subdivided by affinal groups of political or religious association. When families split off from Rama Cay and relocated, their choice of new places of residence is often motivated by their established kin network; therefore, decisions regarding where to relocate are not random. This is exemplified by the progressive colonization of Mestizo peasants in Zompopera and the pressure for land and resources. As a result of this pressure, families place their houses within short distances of one another for protection against physical and psychological violence (Baldi 2007/2009; Riverstone 2004). The isolation of Zompopera has impacted gene frequencies and marital patterns as exemplified in two separate analyses: mtDNA and surname structure. The first of these analyses show that almost 50% of the B2 haplotypes correspond to only one haplotype, CA4, and that 50% of the A2 correspond with haplotype CA8

as it was explained in previous sections. The increased frequency of these two haplotype variants is explained by marriages when they occur among few kin lineages. The second study on surnames shows that 51% of a total of 82 individuals surveyed share 3 surnames ( $\Phi_{ii} = 0.023$ ). Based on these results, it seems likely that the isolation of this community and the low number of potential mates is partly responsible for the increase of these two haplogroup variants.

### ***CULTURAL AND ENVIRONMENTAL EFFECTS ON DEMOGRAPHIC STRUCTURE***

Genetic structure is dependent on changes in fertility, mortality, and migration across time and space. The biodemographic information generated in this investigation indicates that the Rama have an expanding population in which the sex and age distribution may be depicted with a wide base and a gradual diminution of intermediated age groups topped by a slighter augmentation in the older ages and immigrants older than 46 years. Population density increased in the lowlands of the Caribbean region from 5.1% to 15%, evidencing an increase of immigration to the area. Additional indicators of immigration are revealed by the exogamic relationships between non-Rama males and Rama females in recent years. This could be a result of the increasing internal migration to eastern Nicaragua (PAHO 2007). The demographic profile for the Rama shows a reduction in child mortality and the improvement of the survivorship of children of less than 15 years of age after the year 2002. Child mortality (< 4 year old) was also low for the *comarca* of Rama Cay which includes other, non-Rama communities, between 2004 and 2008. However, it increased in years associated with natural disasters such as hurricanes. The sex ratio is slightly lower for males in the total population. Women in their reproductive ages account for around 24% and children under 14 years comprise 43% of the population according to the Nicaraguan national census taken in 2005 (A.S.P.I.A.L 2012). These figures do not entirely correspond with the census carried out by the GTR-K (2007)

because a different definition of ethnicity was applied, thus it provides a good approximation of the population structure in recent years. The population estimate of fewer than 1500 Rama individuals inhabiting southern Nicaragua obtained through this research overlaps with the GTR-K estimate.

At 6.2, the estimated TFR of the Rama women is higher than the TFR of 3.9 in the southern Caribbean region of Nicaragua in 2005 (INIDE 2008d), but lower than the estimated TFRs of 8.05 among Miskito Amerindians and 10.2 among the Sumo of Nicaragua in 1995. Nevertheless, the TFR of the Rama is similar to the Bribri (6.75) and Boruca (6.37) from Costa Rica according to the 2000 census (Perez-Brignoli 2005). The relatively high natality and the survivorship of children among the Rama may be attributed to the collaboration of health professionals and midwives. Based on the assisted birth records from the clinic of Rama Cay, child mortality was noticeably reduced between 2003 and 2008 when this collaboration was implemented. According to Coe (2008), Rama midwives use a total of 162 plant species in maternal care. Of these, over 90% have bioactive properties. The ethnopharmacopoeia of the Rama provide care in prenatal, parturition, postpartum, newborn, and other factors affecting female reproduction. The same author stated that among the Rama, the midwife's role in delivering children is the most important practice carried out at homes and not in health clinics; however, this study documents the contrary. Between 1997 and 2002 midwifery accounted for 60% of total maternal care while only 40% was attributed to biomedical intervention. At the beginning of this period, child mortality was high and its decline in recent years may be due, as stated earlier, to collaboration between midwives and biomedical professionals. Until the 1920s, births were attended only by midwives (*apa*) in huts called *Kuma aing nguu* built specifically for childbirth and menstruation. It was customary that women stay indoors six weeks after

parturition (Conzemius 1927). The implication of the relationship of biomedicine and traditional practices in childcare and survivorship is a tantalizing subject for further exploration in future research among the Rama.

In RAAS and the *municipio* of Bluefields, acute respiratory infections (pneumonia, influenza, and bronchitis) and diarrhea are the leading causes of death; whereas respiratory diseases, homicide and accidents account for the main causes of death among the Rama and the *comarca* in recent years. The cross-correlation analysis between these three groups (RAAS, *comarca*, and Rama Amerindians [based on Moravian records]) indicates that mortality patterns were only correlated between the *comarca* and the Rama but not with RAAS during 1996 and 2008. This analysis suggests that the periodicity of mortality between Mestizo and Rama communities was largely a result of their common exposure to internal, unresolved disputes, land invasions, and other causes. At RAAS, mortality followed a different pattern, however, the periodicity for these three aggregates might have been similar before 1996 if mortality was mainly caused by the exposure of similar environmental conditions (Lin and Crawford 1983). A larger data set is necessary in order to explore this hypothesis.

A separate analysis (ARIMA) based on death records of the Rama from 1975 until 2008 demonstrates a pattern of high mortality every ~7-8 years, followed by more frequent but less numerous fatalities every ~3 years. This trend in mortality was interpreted as the combined effects of cultural and environmental factors such as hurricanes, conflicts, and overcrowding. Offen (1999) estimated that hurricanes struck the Caribbean region every 3 to 5 years from 1865 until 1988. Environmental degradation and natural disasters are known to increase vulnerability to disease and mortality in human populations (Coller and Webb 2002). Eastern Nicaragua is the region most affected by tropical storms and hurricanes responsible for the destruction of

infrastructure, agriculture, forests, and human casualties. Official reports counted 170 climatic disasters during the 20<sup>th</sup> century that also have also been documented in ethnohistorical and historical accounts since the 17<sup>th</sup> century (Offen 1999; Rodriguez et al. 2007). Hurricanes and floods are associated with outbreaks of cholera, food emergencies, leptospirosis, contamination of water supplies, and higher rates of respiratory and vector-borne diseases (PAHO 2003; PAHO 2007). In southeastern Nicaragua, Bluefields and Rama Cay are particularly vulnerable as they are the most impacted by climatologic disasters. In addition, the inability of the population to control epidemics in Nicaragua and the Rama territory during the war in the 1980s increased the risk of infectious diseases and mortality (Garfield et al. 1987).

At RAAS, acute ailments such as diarrhea, pneumonia, and other pulmonary-associated diseases are the most numerous. In the last decade other, less frequent maladies such as food poisoning, meningitis, HIV, and rabies were reported. Vector-borne transmitted diseases such as dengue and malaria have been significantly reduced due to the effective health campaigns (PAHO 2009). At the *comarca*, respiratory diseases and diarrhea comprised the most commonly consulted cases at the clinic, rates of respiratory-related diseases and parasitosis are high and steady. Cases of diarrhea and urinary tract infections have grown in recent years and are particularly high at Rama Cay during hurricane seasons. In comparison, in the 18<sup>th</sup> century, smallpox, rubella, chicken pox, cold, and cholera, as well as parasitic and skin diseases, some of them brought by Europeans, were the most common (Romero 1995).

The role of the environment (i.e., socio-economic conditions, sanitation, and settlement patterns) might have had a different impact on the load, the ecology, and the evolution of disease among the Rama through time. The recent change in settlement patterns from separated households spread across the territory to centralized and highly dense communities such as Rama

Cay may have augmented the probability for the increase in infectious organisms. Other socially disruptive factors such as warfare, forced relocation, and poverty also exacerbate disease susceptibility in human populations and are strong selective agents (Ramenofsky et al. 2003; Rousham and Humphrey 2002). Among these factors poverty is the primary determinant of health in Nicaragua (PAHO 2009) and its status among the Rama as determined by the basic needs indicator (BNI) from INIDE (2008b) demonstrated that crowding, inadequate housing, pollution of water supplies, economic dependence, and extreme poverty, among other variables, may account for the elevated incidence of acute infectious diseases, mainly lower respiratory infections, diarrhea, and parasitosis, that are the main causes of death in children.

The basic needs indicator among the *municipio* of Bluefields and the *comarca* of Rama Cay calculates crowding as the number of individuals accommodated in the same household. Houses that accommodate twenty or more individuals usually belong to the same kin group. Among the Rama communities, the island of Rama Cay has the least habitable area (~ 0.18 km<sup>2</sup>) and is the most crowded (0.43 inhabitants per m<sup>2</sup>). In 2005, 121 houses were counted in Rama Cay, but this number has increased in recent years. Due to limited construction space, houses are often built in the backyards of relatives or in swampy areas unsuited for construction. This crowding has resulted in increasingly contaminated water supplies and deficient roofs, walls, and floors in many homes. Houses without satisfactory water supplies or sewage systems are classified as having inadequate basic services. Punta Fria, Punta Aguila and Kukra River present high indexes of insufficient services (INIDE 2008b). This indicator is comparatively low in Rama Cay due to the recent acquisition of public electricity, the concrete pathway that crosses the island, the health clinic, the school, the church, and a few other public buildings; however, during fieldwork it was noted that water from wells are polluted by the poor treatment of human



and animal waste as well as by garbage. Despite the existence of pit latrines, people defecate in open areas near the island's shore, augmenting the possibility of contaminating residents and the likelihood of disease. During the rainy season, families collect water in containers while in the dry season, most water for drinking and washing is obtained from water pits and boiled or chlorinated.

Finally, low values of selection intensity among the Rama ( $I = 0.32$ ) is correlated with a low pressure of natural selection. This may be due to the combination of health awareness, and the improvement of health policies and maternal care on child survival (Pavard et al. 2007). The low intensity of selection, along with lower mortality index ( $Im = 0.23$ ), may suggest a future epidemiological and demographic transition due to the reduction of mortality at early ages and the shape of the genetic and demographic structure (Rousham and Humphrey 2002).

## ***SUMMARY***

In this chapter, maternal genetic signatures and biparentally transmitted surnames were combined with the ethnohistory of the Rama in order to explore the causes of geographical variation and migration among this population. In addition, the impact of recent historical events is discussed based on the demographic structure and changes in health, mortality, and natality. It was determined that the population disruption caused after the European conquest produced significant changes in the demographics, social organization, and genetic structure of the Rama. At the regional level, this population shares a maternal genetic affinity with Central and South American Chibchan groups and is suggestive of their common biological history.

## VII – CONCLUSION

More than fifty years have passed since James Neel acknowledged the importance of the environment in shaping genetic structure, making fieldwork fundamental for geneticists and anthropologists who wished to understand *in vivo* the forces of evolution acting on human populations. However, with growing technological developments and the genetic revolution (Crawford 2007a), fieldwork has been deemphasized as was predicted by Derek Roberts (1980) decades ago. Fortunately, in recent years, there has been recognition of the importance of cultural niches and social practices as factors of selection and structure among human populations, phenomena which can only be comprehended through analysis of an ethnographic context (Baker and Sanders 1972; Crawford 2007b; Donnelly and Foley 2001; Fix 1999; Roberts 1993).

The methodological design used in this research applied coalescence theory to mtDNA for contextualizing changes in gene frequencies over time and across space. Genetic and demographic structures were evaluated using ethnographic data (surnames, genealogies) ethnohistorical sources, and mitochondrial lineages. This dissertation addressed the following questions: 1) What does genetic variation based on mtDNA reveal about the population history of the Rama in a broad context of regional human geography?, 2) What forces of evolution are impacting this population?, 3) What are the relative impacts of recent historical events on population structure?, 4) What are the consequences of cultural practices and the environment on the biodemography of the Rama?, and 5) Is there any concordance of genetic, archeological, ethnohistorical, and linguistic information with the history of the Rama?

According with this investigation, Chibchans and Mesoamerican populations share common ancestry but experienced different trajectories of linguistic and cultural evolution. This interpretation is supported by statistical tests, the application of coalescent theory and previous research on autosomal, Y-chromosome and mtDNA markers (Melton 2008; Melton et al. 2007; Reich et al. 2012) built on preceding investigations of microevolution in Central America and South America (Barrantes et al. 1990; Batista et al. 1995; Bieber et al. 1996; Kolman and Bermingham 1997; Kolman et al. 1995; Melton 2008; Melton et al. 2007; Torroni et al. 1994). It is likely that the genetic structure of the Chibchans was sculpted by the transition to Holocene ecologies, tribal social structures, and their relative isolation.

As a result of anvironmental changes and migratory processes, proto-Mesoamerican and proto-Chibchans split around 10,000 YBP, followed by a rapid fragmentation that give rise to the Chibchans of southern Central America and another related group that migrated along the Caribbean coast to South America. The Rama and most other Chibchan groups experienced population expansion around 7,000 YBP. Votic populations including the Rama share a number of mtDNA lineages and linguistic elements that match those of South American Chibchan speakers. Limited gene flow, which likely occurred between Votic and other southern Central American populations, was significantly reduced in approximately the second millennium BCE. This event is associated with the adoption of agriculture and village life. It is likely that Pan Caribbean relations allowed gene flow between the Rama and the pre-Columbian Arawak (300 BCE - 800 CE), however, this proposal is tentative until it is confirmed with with greater genetic resolution. Likewise, African admixture was detected in one Rama female due to recent admixture.

A detailed analysis of phylogenetic networks and mismatch distributions depicts a recent population expansion that is thought to be associated with the colonial disruption following the 16<sup>th</sup> century. This demographic event drove the Rama and other populations to re-locate to the so-called refuge of Río San Juan where new genetic variants were acquired and diffused through gene flow among them. At the end of the 18th century, as a result of European conflicts over the control of this region and the spread of diseases, the Rama were forced to settle at Rio Punta Gorda where another, ethnically related group (central population) partially merged with them.

Due to the rise of a capitalist market economy at the end of the 19th and 20th century, Caribbean Nicaragua became an important arena of immigration and pressure for local resources. In this context, a new era of changes in sociocultural patterns and population structure began when a faction of the Rama separated from Punta Gorda and colonized the island of Rama Cay and the vicinity of the Bay of Bluefields; it then back-migrated to the Indian and the San Juan Rivers (peripheral population). The genetic structure of these central and peripheral groups suggests two evolutionary stories in concordance with their relative geographic isolation, migration, and kin structure. The peripheral group could represent a remnant population of the colonial Voto, who were confined to the San Juan River refuge before migrating north in the 18th century while central group may have remained in the region of Punta Gorda for generations.

Competition for land and marine resources by immigrants from the Pacific region of Nicaragua has constrained the movement of the Rama within their territory and resulted in the formation of permanent communities on the Caribbean. Demographic, migratory, and health and disease data documented in this study confirm that high rates of overcrowding and poverty have had an impacted upon disease and mortality rates in contrast with the better public health of other

areas in Eastern Nicaragua. This is exemplified by the increase in respiratory, infectious, and parasitic diseases, which along with accidents and homicide, are major causes of mortality. These maladies increase with the hurricane seasons that frequently have an impact upon Nicaragua's Caribbean coast. The combination of environmental and cultural factors such as disasters, overcrowding, and conflict has increased the vulnerability of the Rama in recent years but has also strengthened their collective abilities to confront adversity. Fortunately, the cultural capital embedded in social networks (kin structure networks), has provided an effective means of cooperation among individuals and groups for generations. It has cushioned the negative effect of these factors. For example, indigenous knowledge and collaboration between health professionals and midwives to provide pre- and postnatal care for pregnant women is thought to have increased the probability of child survivorship. This partnership deserves special attention since the decline in child mortality is correlated with low intensity of natural selection experienced by the Rama in recent years.

The integrative perspective of this research contributes to expanding the few available historical and anthropological data on the Rama by exploring the role that cultural practices and historical events have played on affecting genetic structure. Hence, the change in gene frequencies due to the effect of cultural practices and geography is an important element for bioanthropological studies and deserves attention in future research in Central America. It is hoped that the biological, demographic, and historical information generated from this study will help shape the foundation of knowledge to design future multidisciplinary studies among other marginal and underrepresented populations in Central America.

## BIBLIOGRAPHY

- A.S.P.I.A.L. 2012. Atlas Sociolingüístico de Pueblos Indígenas en América Latina. URL <http://atlaspueblosindigenas.wordpress.com/>.
- Achilli A, Perego UA, Bravi CM, Coble MD, Kong QP, Woodward SR, Salas A, Torroni A, and Bandelt HJ. 2008. The Phylogeny of the Four pan-American MtDNA Haplogroups: Implications for Evolutionary and Disease Studies. *PLoS ONE* 3(3):e1764.
- Alfonso-Sánchez MA, Calderón R, and Peña J. 2004. Opportunity for Natural Selection in a Basque Population and its Secular Trend: Evolutionary Implications of Epidemic Mortality. *Human Biology* 76(3):361-381.
- Anderson S, Bankier AT, Barrell BG, de Bruijn MHL, Coulson AR, Drouin J, Eperon IC, Nierlich DP, Roe BA, Sanger F et al. 1981. Sequence and Organization of the Human Mitochondrial Genome. *Nature* 290:457-465.
- Arias TD, Inaba T, Cooke RG, and Jorge LF. 1988a. A preliminary Note on the Transient Polymorphic Oxidation of Sparteine in the Ngawbé Guaymí Amerindians: A case of Genetic Divergence with Tentative Phylogenetic Time Frame for the Pathway. *Clinical Pharmacology Therapeutics* 44(3):343-352.
- Arias TD, and Jorge L. 1989. An Observation on Uniqueness of the Debrosouquine and Sparteine Antimodes: A Study in the Ngwbe Guaymi Amerinds of Panama. *Br Journal of Clinical Pharmacology* 28:493-494.
- Arias TD, Jorge LF, Lee MD, Barrantes R, and Inaba T. 1988b. The Oxidative Metabolism of Sparteine in the Cuna Amerindians of Panama: Absence of Evidence for Deficient Metabolizers. *Clinical Pharmacology and Therapeutics* 43:456-465.
- Ascunce MS, González-Oliver A, and Mulligan CJ. 2008. Y-Chromosome Variability in Four Native American Populations from Panama. *Human Biology* 80(3):287-302.
- Assandi B. 1983. Rama Cay Creole. In: Holm, editor. *Varieties of English Around the World*. Heidelberg: Gross, J. p 115–122.
- Azofeifa J, Ruiz E, and Barrantes R. 1998. Genetic Variation and Racial Admixture in the Miskito of the Southern Mosquito Shore, Nicaragua. *Revista de Biología Tropical* 46:157-165.
- Azofeifa J, Ruiz E, and Barrantes R. 2001. Blood Group, Red Cell, and Serum Protein Variation in the Cabecar and Huetar, Two Chibchan Amerindian Tribes of Costa Rica. *American Journal of Human Biology* 13:57-64.
- Baker PT, and Sanders WT. 1972. Demographic Studies in Anthropology. *Annual Review of Anthropology* 1:151-178.
- Baldi NF. 2001. Black Creek (cat. UCR No 467): Primeras Interpretaciones Arqueológicas de un Modo de Vida Costero en el Caribe sur de Costa Rica. San José: University of Costa Rica.
- Baldi NF. 2007/2009. Unpublished Field Notes among the Rama Indians, RAAS. Nicaragua.
- Baldi NF. 2010. Coastal Adaptations in the Southern Caribbean Region of Central America: Problems and Perspectives. Manuscript on file. Lawrence, KS: Department of Anthropology, University of Kansas.

- Baldi NF. 2011. Explotación Temprana de Recursos Costeros en el Sitio Black Creek (4000-2500 A.P), Caribe Sur de Costa Rica. *Revista de Arqueología Americana* 29:85-121.
- Baldi NF, and Melton PE. 2010. Understanding the Genetic Structure and Migration of the Rama Indians from the Caribbean Coast of Nicaragua. Abstract at: International Interdisciplinary Conference of Human Migration; March 1-2. University of Kansas.
- Baldi NF, Melton PE, Barrantes R, and Crawford MH. 2008. Diversidad de DNA Mitocondrial en Poblaciones Indígenas Vóticas en el Sur de Centroamérica. Paper presentation at: II Congreso Latinoamericano de Antropología; July 28-31. San José, Costa Rica.
- Bandelt HJ, C. H, Yao YG, Kong QP, Kivisild T, Rengo C, Scozzari R, Richards M, Villems R, Macaulay V et al. 2003. Identification of Native American Founder mtDNAs Through the Analysis of Complete mtDNA Sequences: Some Caveats. *Ann Hum Genet* 67:512-524.
- Bandelt HJ, Forster P, and Röhl A. 1999. Median-joining Networks for Inferring Intraspecific Phylogenies. *Molecular Biology and Evolution* 16(1):37-48.
- Barahona A. 1993. 10 Años de Trabajo Arqueológico en Nicaragua y sus Perspectivas de Desarrollo. *Cuadernos de Antropología* 9:49-57.
- Barker FK. 2007. Avifaunal Interchange Across the Panamanian Isthmus: Insights from *Campylorhynchus* wrens. *Biological Journal of the Linnean Society* 90(4):687-702.
- Barrai I, Formica G, Scapoli C, Beretta M, Mamolini E, Volinia S, Barale R, Ambrosino P, and Fontana F. 1992. Microevolution in Ferrara: Isonymy 1890–1990. *Annals of Human Biology* 19(4):371-385.
- Barrai I, Rodríguez-Larralde A, Manni F, and Scapoli C. 2002. Isonymy and Isolation by Distance in the Netherlands. *Human Biology* 74(2): 263-283.
- Barrai I, Scapoli C, Beretta M, Nesti C, Mamolini E, and Rodriguez-Larralde A. 1996. Isonymy and Genetic Structure of Switzerland I. The Distribution of Surnames. *Annals of Human Biology* 23:431-455.
- Barrantes R. 1993. Evolución en el Trópico: Los Amerindios de Costa Rica y Panamá. San José: Editorial de la Universidad de Costa Rica.
- Barrantes R. 1998. Origen y Relación entre los Amerindios Chibcha de Costa Rica: Una Perspectiva Genética y Evolutiva. In: Bozzoli ME, Barrantes R, Obando D, and Rojas M, editors. I Congreso Científico de Pueblos Indígenas y sus Fronteras. San José: EUNED.
- Barrantes R, Smouse PE, Mohrenweiser HW, Hershowitz H, Azoifeifa J, Arias TD, and Neel J. 1990. Microevolution in Lower Central America: Genetic Characterization of the Chibcha-speaking Groups of Costa Rica and Panama and a Consensus Taxonomy Based on Genetic and Linguistic Affinity. *American Journal of Human Genetics* 46:63-84.
- Barrantes R, Smouse PE, Neel JV, Mohrenweiser HW, and Gershowitz H. 1982. Migration, Genetic Infraestructure of the Central American Guaymi and their Affinities with other Tribal Groups. *American Journal of Physical Anthropology* 58: 201-214.
- Barse WP. 1990. Pre-ceramic Occupations in the Orinoco River Valley. *Science* 250:1388-1390.
- Bataillon G, and Galindo V. 2007. Protestantismo Moravo y Establecimiento de Nuevos Habitus entre los Misquitos Nicaragüenses (1848-2000). *Estudios Sociológicos* 25(73):41-68.
- Batista OI, Kolman CJ, Arias TD, Guionneau-Sinclair F, and Bermingham E. 1998. Variación de ADNmt de dos Tribus Amerindias Chibchas, Los Ngobe y Cuna, Panamá. In: Bozzoli ME, Barrantes R, and Rojas M, editors. Primer Congreso Científico sobre Pueblos Indígenas de Costa Rica y sus Fronteras. San José: EUNED.

- Batista OI, Kolman CJ, and Bermingham E. 1995. Mitochondrial DNA Diversity in the Kuna Amerinds of Panama. *Human Molecular Genetics* 4:921-929.
- Battistuzzi G, Biondi G, Rickards O, Astolfi P, and De Stefano GF. 1986. Historical and Demographic Factors and the Genetic Structure of an Afroamerican Community of Nicaragua. In: Roberts DF, and De Stefano GF, editors. *Genetic Variation and its Maintenance*. Cambridge: Cambridge University Press. p 180-189.
- Baudez C. 1970. *Central America*. London: Barrie and Jenkins.
- Baudez C, and Coe M. 1962. Archaeological Sequences in Northwestern Costa Rica. In: Baldus H, 366-373, editor. *Akten des 34 Internationalen Amerikanistenkongresses*. Wien, 18-25. Juli 1960: Vrlg Ferdinand Berger.
- Behling H. 2000. A 2860-Year High-resolution Pollen and Charcoal Record from the Cordillera de Talamanca in Panama: A History of Human and Volcanic Forest Disturbance. *Holocene* 10:387-392.
- Bell CN. 1862. Remarks on the Mosquito Territory, its Climate, People, Productions, &c., &c., with a Map. *Journal of the Royal Geographical Society of London* 32:242-268.
- Bergoeing JP, and Protti R. 2006. Geomorfología Paleo-Lacustre del Sur del Lago de Nicaragua. *Revista Geográfica* 139:27-38.
- Bertilsson L. 1995. Geographical/Interracial Differences in Polymorphic Drug Oxidation. Current State of Knowledge of Cytochromes P450 (CYP) 2D6 and 2C19. *Clinical Pharmacokinet* 29(3):192-209.
- Bhasin MK, and Walter H. 2007. Genetic Markers in Human Blood. In: Bhasin V, and Bhasin MK, editors. *Anthropology Today: Trends, Scope and Applications*. Haryana, India: Kamla-Raj Enterprises. p 247-347.
- Bieber H, Bieber S, Rodewald A, and Barrantes R. 1996. Microevolution and Genetic Affinities Among Six Amerindian Tribes of Lower Central America: Comparative Genetic Study of Serum Proteins. *Human Biology* 68(6):929-953.
- Boattini A, Calboni FCF, and Vicente C. 2012. Biodemography Functions, Biodem Package for R. CRAN.
- Boles TC, Snow CC, and Stover E. 1995. Forensic DNA Testing on Skeletal Remains from Mass Graves - a Pilot Project in Guatemala. *Journal of Forensic Sciences* 40: 349-355.
- Box GEP, Jenkins GM, and Reinsel GC. 1994. *Time Series Analysis*. Englewood Cliffs, NJ: Prentice-Hall Inc.
- Brass W. 1975. *Methods for Estimating Fertility and Mortality from Limited and Defective Data*. Chapel Hill: The Carolina Population Center.
- Brass W. 1996. Demographic Data Analysis in Less Developed Countries: 1946-1996. *Population Studies* 50,(3):451-467.
- Bray W. 1984. Across the Darien Gap: A Colombian view of Isthmian archaeology. In: Lange FW, and Stone D, editors. *The Archaeology of Lower Central America*. Albuquerque: School of American Research and University of New Mexico Press. p 305-340.
- Brenes W, and Barrantes R. 1983. Salud y Morfología Dental de los Amerindios Guaimíes de Limoncito. *América Indígena* XLIII: 217-232.
- Brenes W, and Barrantes R. 1986. Antropología Dental y Salud Oral de Cinco Poblaciones Amerindias de Costa Rica. In: Barrantes R, Bozzoli ME, and Gudino P, editors. *Memorias del Primer Simposio Científico sobre Pueblos Indígenas de Costa Rica*. San José, C.R.: Instituto Geográfico Nacional.



- Briggs P. 1989. *Art, Death and Social Order: The Mortuary Arts of Pre-Conquest Central Panama*. Oxford: B.A.R. International Series.
- Bronberg RA, Dipierri JE, Alfaro EL, Barraí I, Rodríguez-Larralde A, Castilla EE, Colonna V, Rodríguez-Arroyo G, and Bailliet G. 2009. Isonymy Structure of Buenos Aires City. *Human Biology* 81(4):447-461.
- Brouns G, De Wulf A, and Constaes D. 2003. Delaunay Triangulation Algorithms Useful for Multibeam Echosounding. *J Surv Engrg* 129:79-84.
- Butler JM. 2005. *Forensic DNA Typing Biology, Technology, and Genetics of STR Markers*. Burlington, MA: Elsevier Academic Press.
- Callaghan RT. 2003. Comments on the Mainland Origins of the Preceramic Cultures of the Greater Antilles. *Latin American Antiquity* 13(3):323-338.
- Callaghan RT. 2008. Pattern of Contact between the Islands of the Caribbean and Surrounding Mainlands as a Navigation Problem. In: Curret LA, editor. *Islands in the Stream: Interisland and Continental Interaction in the Caribbean*. Tuscaloosa: University of Alabama Press.
- Callaghan RT, and Bray W. 2007. Simulating Prehistoric Sea Contacts Between Costa Rica and Colombia. *Journal of Island and Coastal Archaeology* 2:4-23.
- Cann RL, Stoneking M, and Wilson AC. 1987. Mitochondrial DNA and Human Evolution. *Nature* 325(1987):31-36.
- Carmack R. 1994. *Historia Antigua*. San José, Costa Rica: FLACSO.
- Catillero A. 1995. *Conquista, Evangelización y Resistencia*. Panamá: Instituto Nacional de Cultura, Dirección Nacional de Extensión Cultural.
- Cavalli-Sforza LL, and Edwards AWF. 1967. Phylogenetic Analysis Models and Estimation Procedures. *American Journal of Human Genetics* 19: 233-257.
- Cavalli-Sforza LL, and Wang WY. 1986. Spatial Distance and Lexical Replacement. *Language* 62:38-55.
- Center E-W. 1992. EASWESPOP: Fertility Estimate Programs Microcomputer Software. In: CENTER E-W, editor. 2.0 ed. Honolulu.
- Chakraborty R. 1985. A Note on the Calculation of Random RP and Its Sampling Variance. *Human Biology* 57:713-717.
- Chamberlain A. 2009. Archaeological Demography. *Human Biology* 81(2-3):275-286.
- Chapman AM. 1958. *An Historical Analysis of the Tropical Forest Tribes on the Southern Border of Mesoamerica*. New York: Columbia University.
- Chávez ML. 2013. Validación de Fechas de Radiocarbono Etapa II del Proyecto Hidroeléctrico Reventazón. Proyecto Hidroeléctrico Reventazón Gestión Ambiental (Arqueología). San Jose: I.C.E.
- Chávez S, Fonseca O, and Baldi NF. 1996. Investigaciones Arqueológicas en la costa Caribe sur de Costa Rica. *Revista de Arqueología Americana* (10):123-161.
- CIDCA. 1993. *Ethnographic Notes on the Rama Indians of Nicaragua: Centro de Investigación y Documentación de la Costa Atlántica-FADCANIC*.
- Clark C, Dawson FG, and Drake JC. 1984. *Archaeology on the Mosquito Coast: A Reconnaissance of the Pre-Columbian and Historic Settlement along the Rio Tinto*. Cambridge: Center for Latin American Studies.
- Clemente I, Gassiot E, and García V. 2007. Población Pre-colombina en el Sur de Nicaragua en el Cambio de Era. In: Assini H, and Aranegui C, editors. *Excavaciones en el Exterior*.

- Coale AJ, and Trussell TJ. 1974. Model Fertility Schedules: Variations in the Age Structure of Childbearing in Human Populations. *Population Index* 40:185-258.
- Coates AG, Aubry MP, Berggren WA, and Collins LS. 2003. Early Neogene History of the Central American Arc from Bocas del Toro, Western Panama. *Geological Society of America Bulletin* 115:271-287.
- Coe FG. 2008. Rama Midwifery in Eastern Nicaragua. *Journal of Ethnopharmacology* 117:136-157.
- Coe M. 1960. Archeological Linkages with North and South America. *American Anthropologist* 62: 363-393.
- Colantonio S, Fuster V, and Marcellino AJ. 2002. Interpopulation Relationship by Isonymy: Application to Ethnosocial Groups and Illegitimacy. *Human Biology* 74(6):871-878.
- Colantonio S, Lasker GW, Kaplan BA, and Fuster V. 2003. Use of Surname Models in Human Population Biology: A Review of Recent Developments. *Human Biology* 75(6):785-807.
- Colinvaux P. 1997. The History of Forests on the Isthmus from the Ice Age to the Present. In: Coates AG, editor. *Central America: A Natural and Cultural History*. Ann Harbor, Michigan: Yale University Press. p 123-136.
- Colinvaux PA, De Oliveira PE, Moreno PE, Miller MC, and Bush MB. 1996. A long Pollen Record from Lowland Amazonia: Forest and Aridity and Refuge Hypothesis. *Science*(274):85-88.
- Coller M, and Webb RH. 2002. *Floods, Droughts, and Climate Change*. Tucson: University of Arizona Press.
- Constenla A. 1991. *Las Lenguas del Área Intermedia*. San José: Editorial Universidad de Costa Rica.
- Constenla A. 1994. Las lenguas de la Gran Nicoya. *Vínculos* 18-19(1-2):191-208.
- Constenla A. 1995. Sobre el Estudio Diacrónico de las Lenguas Chibchenses y su Contribución al Conocimiento del Pasado de sus Hablantes. *Boletín del Museo del Oro* 38-39:13-56.
- Constenla A. 2002a. Acerca de la Relación Genealógica de las Lenguas Lencas y las Lenguas Misumalpas. *Filología y Lingüística* XXVIII(1):189-205.
- Constenla A. 2002b. Acerca de las relación Genealógica de las Lenguas Lencas y las Lenguas Misumalpas. *Filología y Lingüística* XXVIII(1):189-205.
- Constenla A. 2005. ¿Existe Relación Genealógica entre las Lenguas Misumalpas y las Chibchenses? *Estudios de Lingüística Chibcha* 24:7-85.
- Constenla A. 2008. Estado Actual de la Subclasificación de las Lenguas Chibchenses y de la Reconstrucción Fonológica y Gramatical del ProtoChibchense. *Lingüística Chibcha* XXVII: 117-135.
- Conzemius E. 1927. Die Rama Indianer von Nicaragua. *Zeitschrift Etnologia* 59.
- Conzemius E. 1930. Una Tribu Incomme du Costa Rica: Les Indiens Rama du Rio Zapote. *L'Anthropologie* XL: 93-108.
- Conzemius E. 1932. Ethnographical Survey of the Miskito and Sumu Indians of Honduras and Nicaragua. *Bulletin* 106.
- Conzemius E. 1938. Les Tribus Indiennes de la Cote de Mosquitos. *Anthropos* 33:910-943.
- Cooke R, Ranere AJ, Pearson G, and Dickau R. 2013. Radiocarbon Chronology and Early Human Settlement on the Isthmus of Panama (13,000-7,000 BP) with Comments; Cultural Affinities, Environments, Subsistence, and technological Change. *Quaternary International*.

- Cooke RG. 1995. Monagrillo, Panama's First Pottery: Summary of Research, with New Interpretations. In: Hoopes JW, and Barnett WK, editors. *The Emergence of Pottery: Technology and Innovation in Ancient Societies*. Washington and London: Smithsonian Institution Press.
- Cooke RG. 1997. The Native Peoples of Central America During Precolumbian and Colonial Times. In: Coates AG, editor. *Central America: A Natural and Cultural History*. Ann Arbor, Michigan: Yale University Press. p 137-176.
- Cooke RG. 1998. Human Settlement of Central America and Northernmost South America (14,000-8000 BP). *Quaternary International* 49-50:177-190.
- Cooke RG. 2005. Prehistory of Native Americans on the Central American Land Bridge: Colonization, Dispersal, and Divergence. *Journal of Archaeological Research* 13(2):129-187.
- Cooke RG, and Fonseca O. 1994. El Sur de América Central: Contribución al Estudio de la Región Histórica Chibcha. In: Carmack R, editor. *Historia General de Centro América*. San José, Costa Rica: FLACSO.
- Cooke RG, and Pearson GA. 2002. The Role of the Panamanian land-bridge during the Initial Colonization of the Americas. *Antiquity* 76:931-932.
- Cooke RG, and Ranere AJ. 1984. The "Proyecto Santa Maria": A Multidisciplinary Analysis of Prehistoric Adaptations to a Tropical Watershed in Panama. In: Lange FW, editor. *Recent Developments in Isthmian Archaeology*. Oxford: BAR International Series 212. p 3-30.
- Cooke RG, and Ranere AJ. 1992a. The Origin of Wealth and Hierarchy in the Central Region of Panama (12,000-2,000BP), with Observations on its Relevance to the History and Phylogeny of Chibchan-Speaking Polities in Panama and Elsewhere. In: Lange FW, editor. *Wealth and Hierarchy in the Intermediate Area*. Washington, DC: Dumbarton Oaks. p 243-316.
- Cooke RG, and Ranere AJ. 1992b. Prehistoric Human Adaptations to the Seasonally Dry Forest of Panama. *World Archaeology* 24(1):114-133.
- Cooke RG, and Ranere AJ. 1992b Human Influences on the Zoogeography of Panama: An Update Based on Archaeological and Ethnohistorical Evidence. In: Darwin SP, and Welden AP, editors. *Biogeography of Mesoamerica: Proceedings of a Symposium (Mérida, Yucatán, Mexico, October 26-30, 1984)*, Special Publication of the Mesoamerican Ecology Institute. New Orleans: Tulane University. p21-58.
- Cooke RG, and Sanchez A. 2001. El Papel de Mar y de las Costas en el Panamá Pre-hispanico y del Período de Contacto: Redes Locales y Relaciones Externas. *Revista de Historia*. San José: Universidad de Costa Rica. p 15-60.
- Cooke RG, Sanchez A, and Udagawa K. 2000. An Update on Recent Excavations and New Radiocarbon Dates for Associate Pottery Styles. In: McEwan C, editor. *Chicago: Fitzroy Dearborn Publishers*. p 154-176.
- Cooke RG, and Sánchez LA. 2004. Panamá Prehispánico. In: Castellero C. A, editor. *Historia General de Panamá*. Colombia: D´Vinni Impresores. p 3-46.
- Craig C. 1990. Review: Dictionary of the Rama Language. *International Journal of American Linguistics* 56(2):293-304.
- Craig C, Tibbitts B, and Rigby N. 1986. La Lengua Rama Sobrevive. *WANI (Julio-Sep.)*: 28-46.
- Crawford MH. 1979. Comment on: The Evolutionary Relationships of two Populations: A study of the Guaymi and the Yanomama. *Current Anthropology* 20:384-385.

- Crawford MH. 2001. *The Origins of Native Americans*. Cambridge: Cambridge University Press.
- Crawford MH. 2007a. *Anthropological Genetics: Theory, Methods, and Applications*. New York: Cambridge University Press.
- Crawford MH. 2007b. The Importance of Field Research in Anthropological Genetics: Methods, Experiences and Results. In: Crawford MH, editor. *Anthropological Genetics*. New York: Cambridge University Press. p 79-111.
- Croft W. 2008. Evolutionary Linguistics. *Annual Review of Anthropology* 37: 219-234.
- Cropp S, and Boinski S. 2000. The Central American Squirrel Monkey (*Saimiri oerstedii*): Introduced Hybrid or Endemic Species? *Molecular Phylogenetics and Evolution* 16(3):350-365.
- Crow JF. 1958. Some Possibilities for Measuring Selection Intensities in Man. *Human Biology* 30:1-13.
- Crow JF. 1966. The Quality of People: Human Evolutionary Changes. *Bioscience* 16:863-867.
- Crow JF. 1980. The Estimation of Inbreeding from Isonymy. *Human Biology* (52):1-14.
- Crow JF, and Mange AP. 1965a. Measurement of Inbreeding from the Frequency of Marriages Between Persons of the Same Surname. *Eugenics Quarterly* 12:199-203.
- Crow JF, and Mange AP. 1965b. Measurement of Inbreeding from the Frequency of Marriages Between Persons of the Same Surnames. *Eugen Q* (12):199-203.
- Crow JF, and Mange AP. 1982. Measurement of Inbreeding from the Frequency of Marriages Between Persons of the Same Surname. *Soc Biol* 29(1-2):101-105.
- D'Aloja A. 1939. Informe sobre la Investigación Antropológica-Demográfica Realizada en Centroamérica. Publicación 39. México, DF: Instituto Panamericano de Geografía e Historia. 51 p.
- D'Aloja A. 1940. Sobre la Variabilidad de Algunas Características Antropológicas entre Indígenas Centroamericanos. Publicación 43. México: Instituto Panamericano de Geografía e Historia. 52 p.
- De Stefano GF. 1970-1971. Ricerche di Antropologia Biologica su Popolazioni Nicaraguensi: Nota I - Introduzione. *Rivista di Antropologia* LVII: 207-220.
- De Stefano GF. 1973. A Study of Morphological and Genetic Distance Among four Indian Villages of Nicaragua. *Journal of Human Evolution* 2:231-240.
- De Stefano GF, Formenti D, and Bondioli. 1979. Studio Morfologico di Cinque Popolazioni del Nicaragua. *Antropologia Contemporanea* 2:27-34.
- De Stefano GF, and Jenkins J. 1970-1971. Ricerche di Antropologia Biologica su Popolazioni Nicaraguensi: Nota II - Dati Craniometrici. *Rivista di Antropologia* LVII:221-246.
- De Stefano GF, and Jenkins J. 1972. Contributo per uno Studio Antropologico Comparativo Delle Popolazioni del Nicaragua. *Atti XL Congresso Internazionale Degli Americanisti*. Roma- Genova.
- De Stefano GF, and Jenkins J. 1972-1973. Ricerche di Antropologia Biologica su Popolazioni Nicaraguensi: Nota IV - Colorito Cutaneo. *Rivista di Antropologia* LVIII:302-316.
- De Stefano GF, and Jenkins J. 1974. Osservazioni Preliminari Sulla Distribuzione Degli Antigeni A,B,O e del Sistema RH in Popolazioni Nicaraguensi. *Journal of Human Evolution European Anthropology*.
- De Stefano GF, and Jenkins J. 1976. P.T.C. Tasting Among Three Indian Groups of Nicaragua. *American Journal of Physical Anthropology* 44: 371-374.

- Denevan W. 1976a. Estimating the Unknown. In: Denevan W, editor. *The Native Population of the Americas in 1492*. Madison: University of Wisconsin Press. p 1-12.
- Denevan W. 1976b. The Caribbean, Central America, and Yucatan. In: Denevan W, editor. *The Native Population of the Americas in 1492*. Madison: University of Wisconsin Press. p 35-66.
- Denevan W. 1976c. *The Native Population of the Americas in 1492*. Madison: Wisconsin University Press.
- Diaz C. 1999. Estudio Bio-Antropológico de Rasgos Mortuorios de la Operación 4 del Sitio Arqueológico Cerro Juan Díaz, Panamá Central. Bogotá: Universidad de Los Andes.
- Dickau R, Ranere AJ, and Cooke RG. 2007. Starch Grain Evidence for the Pre-ceramic Dispersals of Maize and Root Crops into Tropical Dry and Humid Forests of Panama. *PNAS* 104(9):3651-3656.
- Dipierri J, Alfaro-Gomez E, Scapoli C, Mamolini E, Rodriguez-Larralde A, and Barrai I. 2005. Surnames in Argentina: A Population Study through Isonymy. *American Journal of Physical Anthropology* 128:199-209.
- Donnelly P, and Foley RA. 2001. Towards an Integrated Approach to Human Evolution. In: Foley RA, and Donnelly P, editors. *Genes, Fossils and Behaviour: An integrated Approach to Human Evolution*. Amsterdam: IOS Press. p 1-12.
- Drennan R, Indrisano GG, Mingyu T, Shelach G, Yamping Z, Linduff KM, and Zhizhong G. 2003. Approaches in Regional Demographic Reconstructions. *Regional Archaeology in Eastern Inner Mongolia: A Methodological Exploration*. Beijing: Science Press. p 122-151.
- Drolet R. 1980. *Cultural Settlement Along the Moist Caribbean Slopes of Eastern Panama*. Urbana: University of Illinois.
- Dupanloup I, Schneider S, and Excoffier L. 2002. A Simulated Annealing Approach to Define the Genetic Structure of Populations. *Molecular Ecology* 11(12):2571-2581.
- Ebenesersdóttir SS, Sigurðsson Á, Sánchez-Quinto F, Lalueza-Fox C, Stefánsson K, and Helgason A. 2011. A New Subclade of mtDNA Haplogroup C1 Found in Icelanders: Evidence of Pre-Columbian Contact? *American Journal of Physical Anthropology* 144(1):92-99.
- Erlandson JM. 2002. Anatomical Modern Humans, Maritime Voyaging, and Pleistocene Colonization of the Americas. In: Jablonsky NG, editor. *The First Americans: The Pleistocene Colonization of The World*. San Francisco, California: Allen Press. p 59-83.
- Erlandson JM, Rick TC, Braje TJ, Caspersen M, Culleton B, Fulfrost B, Garcia T, Guthrie DA, Jew N, Kennett DJ et al. . 2011. Paleoindian Seafaring, Maritime Technologies, and Coastal Foraging on California's Channel Islands. *Science* 331(6021):1181-1185.
- ERN-CAPRA. 2011. Riesgo por Huracán de Bluefields, Informe Técnico. In: Evaluación de Riesgos Naturales AL, Consultores en Riesgos y Desastres, editor. *Análisis Probabilística de Amenazas y Riesgos Naturales, Tomo II: ERN-CAPRA-T2-9*.
- Estee S. 2004. Natality: Measure Based on Vital Statistics. In: Siegel JS, and Swanson DA, editors. *The Methods and Materials of Demography*. London, UK: Elsevier Academic Press. p 371-405.
- Excoffier L, and Lischer H. 2011. *Alequin ver. 3.5*. Computational and Molecular Genetics Lab Switzerland: Institute of Ecology and Evolution, University of Berne.

- Excoffier L, Smouse PE, and Quattro JM. 1992. Analysis of Molecular Variance Inferred From Metric Distances Among DNA Haplotypes: Application to Human Mitochondrial DNA Restriction Data. *Genetics* 131(2):479-491.
- Felsenstein J. 2004. *Inferring Phylogenies*. Sunderland, Massachusetts: Sinauer Associates.
- Fernandez-Guardia R. 1975. *Reseña Histórica de Talamanca*. San José: Editorial Costa Rica.
- Fernández-Guardia R. 1921. *Crónicas Coloniales*. San José, Costa Rica: Trejos Hermanos.
- Fernandez de Oviedo G, editor. 1959 [1535-1557 and 1851-1855]. *Historia General y Natural de las Indias*. Madrid: Ediciones Atlas.
- Fernández L. 1975. *Historia de Costa Rica Durante la Dominación Española; 1502-1821*. San José: Editorial Costa Rica.
- Ferrero L. 2001. *Entre el Pasado y el Futuro: Editorial Costa Rica*. 248 p.
- Fisher RA. 1943. The Relation Between the Number of Species and the Number of Individuals in a Random Sample of an Animal Population: Part 3. The Theoretical Distribution for Apparent Abundance of Different Species. *Journal of Animal Ecology* 12(1):42-58.
- Fitch WM, and Neel JV. 1969. The Phylogenetic Relationships of some Indian Tribes of Central and South America. *American Journal of Human Genetics* 21(4 ):384-387.
- Fix AG. 1999. *Migration and Colonization in Human Microevolution*. Cambridge: Cambridge University Press.
- Fix AG. 2004. Kin-Structured Migration: Causes and Consequences. *American Journal of Human Biology* 16:387-394.
- Fix AG. 2011. Migration in Anthropological Genetics. In: Cabana G, and Clark J, editors. *Rethinking Anthropological Perspectives on Migration*. Gainesville, FL: University Press of Florida. p 248-262.
- Floyd T. 1967. *The Anglo-Spanish Struggle for Mosquitia*. Albuquerque: University of New Mexico Press.
- Fluxus-Technology. 2011. NETWORK. 4.6.1.0 ed.
- Fonseca O. 1987. Historia Antigua del Caribe de Panamá, Costa Rica y Nicaragua. *Avances de Investigación, Universidad de Costa Rica* 28:1-25.
- Fonseca O. 1989. La Arqueología como Historia. In: Fonseca E, editor. *Historia Teoría y Métodos*. San José: Educa.
- Fonseca O. 1992. *Historia Antigua de Costa Rica: Surgimiento y Caracterización de la Primera Civilización Costarricense*. San José: Editorial Universidad de Costa Rica.
- Fonseca O. 1997a. La Cerámica Temprana de Costa Rica en el Contexto del Área Histórica Chibchoide (4000-2500 A.P.). *Revista de Arqueología Americana*(13):41-68.
- Fonseca O. 1997b. La Conformación de los Espacios Históricos, el caso de América Central y el Noroccidente Colombiano. In: INAH, editor. *Memorias del III Simposio Panamericano de Historia*.
- Fonseca O. 1998. El Espacio Histórico de los Amerindios de Filiación Chibcha: El Área Histórica Chibchoide. In: Bozzoli ME, Barrantes R, Obando D, and Rojas M, editors. *I Congreso Científico de Pueblos Indígenas y sus Fronteras*. San José: EUNED.
- Fonseca O, and Cooke RG. 1993. El Sur de América Central: Contribución al Estudio de la Región Histórica Chibcha. In: Carmack R, editor. *Historia General de Centroamérica*. San José: FLACSO. p 217-282.
- Fox WR, and Lasker GW. 1983. The Distribution of Surname Frequencies. *International Statistics Review* 51:81-87.
- Frazer JG. 1939. *The Native Races of America*. London: Percy Lund Humphries & Co LTD.

- Fu Y-X. 1997. Statistical Tests of Neutrality of Mutations Against Population Growth, Hitchhiking and Background Selection. *Genetics* 147:915-925.
- Fuentes L. 1961. Distribucion de los Grupos Sanguineos en Indios Guatusos de Costa Rica. *Revista de Biologia Tropical* 9:131-140.
- Fuselli S, Tarazona-Santos E, Dupanloup I, Soto A, Luiselli D, and Pettener D. 2003. Mitochondrial DNA Diversity in South America and the Genetic History of Andean Highlanders. *Molecular Biology and Evolution* 20:1682-1691.
- Gabb W. 1883. Tribus y Lenguas Indígenas de Costa Rica Colección de Documentos para la Historia Patria In: Fernández L, editor. *Revista del Archivo Nacional*. San José, Costa Rica. p 303-486.
- Garfield RM, Frieden T, and Vermund S. 1987. Health-Related Outcomes of War in Nicaragua. *American Journal of Public Health* 77(5):615-618.
- Gassiot E, and Estévez J. 2004. 6 años de Arqueología en la Costa Atlántica de Nicaragua: Descubrimiento de un Pasado Inédito. *Revista Bienes Culturales* 2.
- Geurds A. 2011. The Social in the Circum-Caribbean. In: Hofman C, and Van-Duijvenbode A, editors. *Communities in Contact: Essays in Archaeology, Ethnohistory, and Ethnography of the Amerindian Circum-Caribbean*. Laiden: Sidestone Press. p 45-59.
- Gnecco C, and Mora S. 1997. Early Occupations of the Tropical Forest of Northern South America by Hunter-Gatherers. *Antiquity* 71:683-690.
- González-Martin A, García-Moro C, Hernández M, and Moral P. 2006. Inbreeding and Surnames: A projection Into Easter Island's Past. *American Journal of Physical Anthropology* 129(3):435-445.
- González F, and Zeledón E. 1999. *Crónicas y Relatos para la Historia de Puerto Limón*. San José: Ministerio de Cultura Juventud y Deportes, Centro de Investigación y Conservación de Patrimonio Cultural.
- Greenberg J. 1987. *Language in the Americas*. Stanford: Stanford University Press.
- Greenberg JH, Li CGT, Zegura SL, Campbell L, Fox JA, Laughlin WS, Szathmari EJE, Weiss KM, and Woolford E. 1986. The Settlement of the Americas: A Comparison of the Linguistic, Dental, and Genetic Evidence [and Comments and Reply]. *Current Anthropology* 27(5):477-497.
- Griggs JC. 2005. *The Archaeology of Central Caribbean Panama*. Austin: University of Texas.
- Grinevald C. 2003. Educacion Intercultural y Multilingue: El Caso de los Rama. *WANI* 34:20-38.
- GTR-K. 2007. *Gobierno Territorial Rama y Kriol. Diagnóstico del Territorio Rama y Kriol. Bluefields, Nicaragua: GTR-K*.
- Guerrero JV, and Solís F. 1997. *Los Pueblos Antiguos de la Zona Cañas-Liberia del año 300 al 1500 despues de Cristo*. San José, Costa Rica: Museo Nacional de Costa Rica.
- Gut J, Catin T, Dayer P, Kronbach T, Zanger U, and Meyer U. 1986. Debrisoquine/Spartine-type Polymorphism of Drug Oxidation. *The Journal of Biological Chemistry* 261(25):11734-11743.
- Haberland W. 1981. América Central: Concepto, Límite y Problema. In: Parada A, editor. *Colección Mispanti*. San Salvador: Ediciones Cuzcatlan.
- Halberstein RA. 1973. *Evolutionary Implications of Demographic Structure of a Transplanted Population in Central Mexico*. Lawrence: Kansas.
- Hall C. 1984. *Costa Rica: Una Interpretación Geográfica con Perspectiva Histórica*. San José: Editorial Costa Rica.

- Hall C, and Perez-Brignoli H. 2003. *Historical Atlas of Central America*. Norman: University of Oklahoma Press. 312 p.
- Hall TA. 1999. BioEdit: A User Friendly Biological Sequence Alignment Editor and Analysis Program For Windows 95/98/NT. *Nucleic Acids Symp Ser* 41:95-98.
- Haller MJ. 2004. *The Emergence and Development of Chiefly Societies in the Rio Parita Valley, Panama*. Pittsburgh: University of Pittsburgh.
- Hammond N. 1982. The Prehistory of Belize. *Journal of Field Archaeology* 9(3):349-362.
- Hansell P. 1988. *The Rise and Fall of an Early Formative Community: La Mula-Sarigua, Central Pacific Panama*: Temple University.
- Hardy ET. 1992. *The Mortuary Behaviour of Guanacaste/Nicoya: An Analysis of Pre-Columbian Social Structure*. Los Angeles, California: University of California.
- Harpending H, and Jenkins T. 1973. Genetic Distance Among Southern African Populations. In: Crawford MH, editor. *Methods and Theories of Anthropological Genetics*. Albuquerque: University of Mexico Press.
- Harpending H, and Rogers A. 1984. ANTANA: Package for Multivariate Data Analysis. V.1.1. [distributed by the authors]
- Harrower DE. 1825. Rama, Mosquito, and Sumu of Nicaragua. *Indian Notes* 1:44-48.
- Hasemann G, Lara Pinto G, and Cruz Sandoval F. 1996. *Los Indios de Centroamérica*. Mexico: MAPFRE.
- Healy ME, and Hunley K. 2008. Gene Bank. Acc. numb: EU566335-EU56359.
- Helms MW. 1969. The Cultural Ecology of a Colonial Tribe. *Ethnology* 8:76-84.
- Herlihy PH, editor. 1997. *Central American Indian Peoples and Lands Today*. Ann Arbor, Michigan: Yale University Press. 215-240 p.
- Hobcraft JN, Goldman N, and Chidambaram VC. 1982. Advances in the P/F Ratio Method for the Analysis of Birth Histories. *Population Studies* 36(2):291-316.
- Hodgson G, Montalvan M, Cordero D, Miller D, and Peralta L. 1993. *Diagnóstico de las Comunidades del Municipio de Bluefields, y del Sub-Municipio de Kukra Hill. Bluefields, RASS, Nicaragua*: INDERA.
- Hofman C, Bright A, and Rodriguez Ramos R. 2010. Crossing the Caribbean Sea: Towards a Holistic View of Pre-Columbian Mobility and Exchange. *Journal of Caribbean Archaeology, Special Publication* (3):1-17.
- Holm JA. 1978. *The Creole English of Nicaragua's Miskito Coast: Its Sociolinguistic History and a Comparative Study of its Lexicon and Syntax*: University of London.
- Holt D. 1997-1998. Another Look at Aztec-Chibchan. *Linguistica Chibcha* 16:81-103.
- Hoopes JW. 2005. *Culturas Chibchas del Litoral Caribe: Explorando Conexiones Precolombinas entre Colombia y Costa Rica*. In: Gnecco C, and González V, editors. *La Arqueología del Area Intermedia: Instituto Colombiano de Antropología e Historia*.
- Hoopes JW, and Fonseca O. 2003. Goldwork and Chibchan Identity: Endogenous and Diffuse Unity in the Isthmo-Colombian Area. In: Quilter J, and Hoopes JW, editors. *Gold and Power in Ancient Costa Rica, Panama, and Colombia*. Washington D.C: Dumbarton Oaks Research Library and Collection.
- Hrdlicka A. 1926. The Indians of Panama. Their Physical Relation of the Mayas. *American Journal of Physical Anthropology* 9:1-15.
- Hünemeier T, Amorim CEG, Azevedo S, Contini V, Acuña-Alonzo V, Rothhammer F, Dugoujon J-M, Mazières S, Barrantes R, Villarreal-Molina MT et al. . 2012.



- Evolutionary Responses to a Constructed Niche: Ancient Mesoamericans as a Model of Gene-Culture Coevolution. *PLoS ONE* 7(6):e38862.
- Hunley K, and Healy M. 2011. The Impact of Founder Effects, Gene Flow, and European Admixture on Native American Genetic Diversity. *American Journal of Physical Anthropology* 146(4):530-538.
- Ibarra E. 1986. La Situación Conflictiva de Talamanca en los Siglos XVI-XVII (1539-1709). In: Barrantes Rea, editor. *Memorias del Primer Simposio Científico sobre Pueblos Indígenas de Costa Rica*. San José: Editorial Instituto Geográfico Nacional. p 13-18.
- Ibarra E. 2011a. Del Arco y la Flecha a las Armas de Fuego. San José: Editorial Universidad de Costa Rica.
- Ibarra E. 2011b. Los Nicaraos, Los Indios Votos y los Huetares en Escenarios Conflictivos en el Siglo XVI. *Cuadernos de Antropología*: 1-24.
- Ibarra E, and Salgado S. 2010. Áreas Culturales o Regiones Históricas en la Explicación de Relaciones Sociales de Pueblos Indígenas de Nicaragua y Costa Rica de los Siglos XV y XVI. *Anuario de Estudios Centroamericanos* 35-36:37-60.
- Incer J. 1975. *Geografía Ilustrada de Nicaragua*. Bogotá: Editora y Distribuidora Nicaragüense.
- Incer J, and Pérez-Valle E. 1999. Descubrimiento y Explotación del Rio San Juan. *Managua: HIPAMER*.
- Ingman M, Kaessmann H, Paabo S, and Gyllensten U. 2000. Mitochondrial Genome Variation and the Origin of Modern Humans. *Nature* 408(6813):708-713.
- INIDE. 2008a. 2008 Anuario Estadístico. Managua, Nicaragua: Instituto Nacional de Información y Desarrollo (INIDE), Sistema Estadístico Nacional (SEN).
- INIDE. 2008b. Bluefields en Cifras. Managua, Nicaragua: Instituto Nacional de Información y Desarrollo (INIDE).
- INIDE. 2008c. Estimación y Proyección de los Componentes Demográficos 1950-2050, a Nivel Nacional. Managua, Nicaragua: Instituto Nacional de Información y Desarrollo (INIDE).
- INIDE. 2008d. Proyecciones Departamentales por Sexo y Grupos de Edad, Capitulo y Anexo 2. Managua, Nicaragua: Instituto Nacional de Información y Desarrollo (INIDE), Sistema Estadístico Nacional (SEN).
- Jackson JBC, and D'Croz L. 1997. The Ocean Divided. In: Coates AG, editor. *Central America: A Natural History*. Ann Arbor, Michigan: Yale University Press. p 38-71.
- Janzen DH, editor. 1983. *Central America Dispersal Route: Biotic History and Paleogeography*. Chicago: The University of Chicago Press. 12-34 p.
- Jobling MA, Hurler ME, and Tyler-Smith C. 2004. *Human Evolutionary Genetics: Origins, Peoples & Disease*. New Delhi, India: Garland Science.
- Johnson F. 1948. Central American Cultures: An introduction. In: Steward J, editor. *Handbook of South American Indians: The Circum-Caribbean Tribes*. New York: Cooper Square. p 43-69.
- Jorge LF, Arias TD, Griese U, Nebert DW, and Eichelbaum M. 1993. Evolutionary Pharmacogenetics of CYP2D6 in Ngawbe Guaymi of Panama: Allele-specific PCR Detection of the CYP2D6B allele and RFLP analysis. *Pharmacogenetics* 3(5):231-138.
- Jurgensen JP. 1858. Mosquito Coast. *Periodical Accounts* 23:40-41.
- Jurgensen JP. 1869 [1894]. Rama Key. *Erlebnisse Dasselbst des Missionars de Brudergemeine*. In: Schneider HG, editor: *Niesky i.d. Ober-Lausitz*.

- Justice A. 2011. Genetic Structure of the Maya in Guatemala: Perspectives on the Population History of the Maya using mtDNA and Y-chromosome Markers. Lawrence: University of Kansas.
- Kaufman T. 1990. Language History in South America: What We Know and How to Know More. In: Paynen DL, editor. Amazonian Linguistics. Austin: University of Texas Press. p 13-74
- Kemble S. 1884a. Journals of Brigadier-General Kemble. In: De Lancey E, Moore G, and Libbey W, editors. The Kemble Papers: Brigadier-General in Command of the Expedition to Nicaragua, 1780-1781. New York: New York Historical Society Publication Fund. p 31-101.
- Kemble S. 1884b. Report of the Mosquito Country. The Kemple papers Vol II 1780-1781. New York: New York Historical Society Collection. p 419-431.
- Keyeux G, Rodas C, Gelvez N, and Carter D. 2002. Possible Migration Routes into South America Deduced from Mitochondrial DNA Studies in Colombian Amerindian Populations. *Human Biology* 74(2):211-233.
- Kimura M. 1968a. Evolutionary Rate at the Molecular Level. *Nature* 217(624-626).
- Kimura M. 1968b. Genetic Variability Maintained in an Infinite Population due to Mutational Production of Neutral and Nearly Neutral Isoalleles. *Genetic Research* 11:247-269.
- Kleinman JC. 1977. Statistical Notes for Health Planners. No. 3. Mortality. Rockville, Md.: National Center for Health Statistics and the Bureau of Health Planning and Resources Development, Health Resources Administration. 77-1237 p.
- Klotz U. 2007. The Role of Pharmacogenetics in the Metabolism of Antiepileptic Drugs: Pharmacokinetic and Therapeutic Implications. *Clinical Pharmacokinetics* 46(4):271-279.
- Koertvelyessy T, Crawford MH, Huntsman M, Collins D, Keeping D, and Uttley M. 1988. Repetition of the Same Pairs of Names in Marriages in Fogo Island, Newfoundland, and Genetic Variation. *American Journal of Physical Anthropology* 77:253-260.
- Kolman CJ, and Bermingham E. 1997. Mitochondrial and Nuclear DNA Diversity in the Choco and Chibcha Amerinds of Panama. *Genetics* 147(3):1289-1302.
- Kolman CJ, Bermingham E, Cooke RG, Ward RH, Arias TD, and Guionneau-Sinclair F. 1995. Reduced mtDNA Diversity in the Ngobe Amerindians of Panama. *Genetics* 41:275-283.
- Kroeber AL. 1992 [1939]. Cultural and Natural Areas of Native North America. In: AA.VV., editor. Una Definición de Mesoamerica. México: UNAM e Instituto de Investigaciones Antropológicas. p 105-139.
- Kumar S, Bellis C, Zlojutro M, Melton PE, Blangero J, and Curran JE. 2011. Large Scale Mitochondrial Sequencing in Mexican Americans Suggests a Reappraisal of Native American Origins. *BMC Evolutionary Biology* 11: 293:2-17.
- Lalueza-Fox C, Gilbert MT, Martinez-Fuentes AJ, and Calafell FB, J. 2003. Mitochondrial DNA from pre-Columbian Ciboneys from Cuba and the Prehistoric Colonization of the Caribbean. *American Journal of Physical Anthropology* 121(2):97-108.
- Lalueza-Fox C, Luna Calderon F, Calafell F, and Bertranpetit J. 2001. MtDNA from Extinct Tainos and the Peopling of the Caribbean. *Ann Hum Genet* 65:137-151.
- Lange FW. 1984. Cultural Geography of Pre-Columbian Lower America. In: Lange FW, and Stone D, editors. The Archaeology of Lower Central America. Albuquerque: University of New Mexico Press. p 33-60.
- Lange FW, Sheets P, Martinez A, and Abel-Vidor S. 1991. The Archaeology of Pacific Nicaragua. Albuquerque: University of New Mexico Press.

- Langston CE, and Heuter KJ. 2003. Leptospirosis. A re-emerging Zoonotic Disease. *Veterinary Clinics of North America, Small Animal Practice* 33(4):791-807.
- Lasker GW. 1968. The Occurrence of Identical (isonymous) Surnames in Various Relationships in Pedigrees: A Preliminary Analysis of the Relation of Surname Combinations to Inbreeding. *American Journal of Human Genetics* 20:250-257.
- Lasker GW. 1969. Isonymy (occurrence of the same surname in affinal relatives): A Comparison of Rates Calculated from Pedigrees, Grave Markers and Death and Birth Registers. *Human Biology* 49:489-493.
- Lasker GW. 1985. *Surnames and Genetic Structure*. Cambridge, UK: Cambridge University Press.
- Lasker GW. 1991. Cultural Factor in the Geographic Distribution of Personal Names: Pseudogenetic Analysis of First Names Used to Estimate the Cultural Component of Coefficients of Relationship by Isonymy. *Human Biology* 63(2):197-202.
- Lasker GW, and Kaplan BA. 1985. Surnames and Genetic-Structure: Repetition of the Same pair of Names of Married Couples, a Measure of Subdivision of the Population. *Human Biology* 57(3):431-440.
- Laurencich L. 1966. Notas Antropométricas sobre los Indios Actuales Borucas, Salitre, Ujarras. *Actas XXXVI Congreso Internacional de Americanistas*. Barcelona - Sevilla. p 122-136.
- Laurencich L. 1968. Notas Antropométricas sobre un Grupo de Indios Guaymi de la Region Sur de Costa Rica. *Memorias del XXXVIII Congreso de Americanistas*. Stuttgart - Munich. p 365-404.
- Laurencich L. 1974. Osservazione Antropologiche Sudium Gruppo di Americi Bribri e Cabecar de Costa Rica. *Archivos per L' Antropologia e La Etnologia CIV*: 79-92.
- Layrisse M, Layrisse Z, and Johannes W. 1963. Blood Group Antigen Studies of Four Chibchan Tribes. *Am Anth* 65:36-55.
- Layrisse Z, Layrisse M, and Rodríguez-Larralde. 1995. Estudios Genéticos en Poblaciones de Lengua Chibcha. *Boletín del Museo del Oro* 38-39:71-85.
- Lehmann W. 1920. *Zentral-Amerika*. Berlin.
- Leon M. 2007. Reporte de una Punta de Lanza Paleoamericana "Cola de Pez" en la Virgen de Sarapiquí, Costa Rica. *Vínculos* 30:147-154.
- Lewis MP, editor. 2009. *Ethnologue: Languages of the World*. 16 ed. Dallas, TX: SIL International.
- Leyden BW. 1995. Evidenze of the Younger Dryas in Central America. *Quaternary Science Reviews* 14:833-839.
- Lin PM, and Crawford MH. 1983. A Comparison of Mortality Patterns in Human Populations Residing Under Diverse Ecological Conditions: A Time Series Analysis. *Human Biology* 55(1):35-62.
- Linares O, and Ranere AJ, editors. 1980. *Adaptive Radiations in Prehistoric Panama*. Cambridge, Massachusetts.
- Linares O, and Sheets P. 1980. Highland Agricultural Villages in the Volcan Baru Region. In: Linares OF, and Ranere AJ, editors. *Adaptive Radiations in Prehistoric Panama*. Cambridge, Massachusetts: Peabody Museum, Monographs No 5. p 44-55.
- Lines J. 1952. *Colección de la Historia de Costa Rica, Relatos al Cuarto y Ultimo Viaje de Cristóbal Colon*. San José: Academia de Geografía e Historia de Costa Rica, Imprenta y Librería Atenea.

- Linné S. 1929. Darien in the Past: the Archaeology of Eastern Panama and North-Western Colombia. In: Kung G, editor. *Vetenskaps och Vitterhets-Samhälles Handlingar, Femte Foldjen, Ser AI, Elanders Boktryckeri Aktiebolag*. Gotedorg.
- Lohse JC, Awe J, Griffith C, Rosenswig RM, and Valdez Jr F. 2006. Preceramic Occupations in Belize: Updating the Paleoindian and Archaic Record. *Latin American Antiquity* 17(2):209-226.
- Lothrop SK. 1926. Pottery of Costa Rica and Nicaragua: Museum of American Indian, Heye Foundation.
- Lothrop SK. 1937. Coclé: An Archaeological Study of Central Panama. Part 1: Peabody Museum of Archaeology and Ethnology, Monograph No 5, Harvard University.
- Lothrop SK. 1942. Coclé: An Archaeological Study of Central Panama. Part 2: Peabody Museum of Archaeology and Ethnology, Monograph No 7, Harvard University
- Loveland F. 1975. Dialectal Aspects of Natural Symbols: Order and Disorder in Rama Indian Cosmology. Ann Arbor: University of Michigan.
- Loveland F. 1976. Snakebite Cure Among the Rama Indians of Nicaragua. In: Grolling FX, and Haley HB, editors. *Medical Anthropology*. Chicago: Mouton Publishers. p 81-101.
- Ma J, Ratan A, Raney BJ, Suh BB, Miller W, and Haussler D. 2008. The Infinite Sites Model of Genome Evolution. *Proceedings of the National Academy of Sciences* 105(38):14254-14261.
- Macbeth H, and Collinson P. 2002. Introduction: The Framework of Studying Human Population Dynamics. In: Macbeth H, and Collinson P, editors. *Human Population Dynamics: Cross-disciplinary Perspectives*. Cambridge: Cambridge University Press. p 1-16.
- Magnus RM. 1974. The Prehistory of Miskito Coast of Nicaragua: A study in Cultural Relationships. Boston, MA: University of Yale.
- Magnus RM. 1978. The Prehistoric and Modern Subsistence Patterns of the Atlantic Coast of Nicaragua. In: Stark BL, and Voohies B, editors. *Prehistoric Coastal Adaptations: The Economy and Ecology of Maritime Middle America*. New York: Academic Press. p 61-80.
- Maldonado-Koerdell. 1964. Geohistory and Paleodemography of Middle America. In: West RC, editor. *Handbook of Middle American Indians: University of Texas Press*.
- Malhi RS, Cybulski JS, Tito RY, Johnson J, Harry H, and Dan C. 2010. Brief Communication: Mitochondrial Haplotype C4c Confirmed as a Founding Genome in the Americas. *Am J Phys Anthropol* 141:494-497.
- Manly BF. 2005. *Multivariate Statistical Methods*. Florida: Chapman & Hall/CRC.
- Manni F, and Guerard E. 2004. Barrier vs 2.2. Manual of the User. Population Genetics Team. Paris [Publication distributed by the authors]: Museum of Mankind (Musée de l'Homme).
- Manni F, Guerard E, and Heyer E. 2004. Geographic Patterns of (Genetic, Morphologic, Linguistic) Variation: How Barriers can be Detected by "Monmonier's Algorithm". *Human Biology* 76(2):173-190.
- Mantel N. 1967. The Detection of Disease Clustering and a Generalized Regression Approach. *Cancer Research* 27:209-220.
- Martínez-Cruzado JC. 2010. The History of Amerindian Mitochondrial DNA in Puerto Rico. In: Fitzpatrick S, and Roos AH, editors. *Island Shores and Distant Pasts*. Gainesville: University Press of Florida. p 54-80.

- Martínez-Cruzado JC, Toro-Labrador G, Viera-Vera J, Rivera-Vega MY, Startek J, Latorre-Esteves M, Román-Colón A, Rivera-Torres R, Navarro-Millán IY, Gómez-Sánchez E et al. . 2005. Reconstructing the Population History of Puerto Rico by Means of mtDNA Phylogeographic Analysis. *American Journal of Physical Anthropology* 128(1):131-155.
- Matson AG, Sutton HE, Swanson J, Robinson AR, and Santiana A. 1966. Distribution of Hereditary Blood Groups Among Indians in South America. I. In Ecuador. *Am J Phy Anth* 24:51-70.
- Matson AG, and Swanson J. 1963a. Distribution of Hereditary Blood Antigens Among Indians in Middle America: III. In Guatemala. *Am J Phy Anth* 21:301-317.
- Matson AG, and Swanson J. 1963b. Distribution of Hereditary Blood Antigens Among Indians in Middle America: V. In Nicaragua. *American Journal of Physical Anthropology* 21:545-559.
- Matson AG, and Swanson J. 1964a. Distribution of Blood Groups Among Indians in Middle America: IV. In Honduras. *Am J Phy Anth* 22:319-332.
- Matson AG, and Swanson J. 1964b. Distribution of Hereditary Blood Antigens Among Indians in Middle America: VI. In British Honduras. *Am J Phy Anth* 21:271-284.
- Matson AG, and Swanson J. 1965a. Distribution of Hereditary Blood Antigens Among Indians in Middle America: VIII. In Panama. *American Journal of Physical Anthropology* 23:413-426.
- Matson AG, and Swanson J. 1965b. Distribution of Hereditary Blood Antigens Among Indians in Middle America: VII. In Costa Rica. *American Journal of Physical Anthropology* 23:107-122.
- McCafferty GC. 2008. Domestic practice in Postclassic Santa Isabel, Nicaragua. *Latin American Antiquity* 19(1):64-82.
- McGehee MA. 2004. Mortality. In: Siegel JS, and Swanson DA, editors. *The Methods and Materials of Demography*. 2 ed. London, UK: Elsevier Academic Press. p 265-300.
- Meggers B. 1998. *Evolución y Difusión Cultural: Enfoques Teóricos para la Investigación Arqueológica*. Quito, Ecuador: Ediciones Aby-Yala.
- Melton P, Baldi NF, Barrantes R, and Crawford MH. 2013. Microevolution, Migration, and the Population Structure of Five Amerindian Populations from Nicaragua and Costa Rica. *American Journal of Human Biology* In press.
- Melton PE. 2008. *Genetic History and Pre-columbian Diaspora of Chibchan Speaking Populations: Molecular Genetic Evidence*. Lawrence: University of Kansas.
- Melton PE, Baldi NF, Barrantes R, and Crawford MH. 2010. Microevolutionary Analysis of Y-Chromosome Variation in Five Native American Populations from Lower Central America. Abstract: American Association of Physical Anthropologists (AAPA); April 14-17. New Mexico.
- Melton PE, Briceno I, Gomez A, Devor EJ, Bernal JE, and Crawford MH. 2007. Biological Relationships Between Central and South American Chibchan Speaking Populations: Evidence From mtDNA. *American Journal of Physical Anthropology* 133(1):753-770.
- Menzies A. 2009. *Craft Specialization and Emergence of the Chiefly Central Place Community of He-4 (El Hatillo), Central Panama*. Pittsburgh: University of Pittsburgh.
- Merriwether DA, Kemp BM, Crews DE, and Neel JV. 2000. Gene Flow and Genetic Variation in the Yanomama as Revealed by Mitochondrial DNA. In: Renfrew C, editor. *America Past, America Present: Genes and Languages in the Americas and Beyond*. Cambridge, UK: Cambridge University Press.

- Meyer S, Weiss G, and von Haeseler A. 1999. Pattern of Nucleotide Substitution and Rate Heterogeneity in the Hypervariable Regions I and II of Human mtDNA. *Genetics* 152(3):1103-1110.
- Mielke JH, Koningsberg LW, and Relethford J. 2006. *Human Biological Variation*. New York: Oxford University Press.
- Miller MP. 2005. Alleles in Space (AIS): Computer Software for the Joint Analysis of Interindividual Spatial and Genetic Information. *The Journal of heredity* 96(6):722-724.
- MINITAB. 2003. State College, PA: MINITAB Inc.
- Monmonier MS. 1973. Maximum-Difference Barriers: An Alternative Numerical Regionalization Method. *Geographical Analysis* 5(3):245-261.
- Moon JH. 1994. Putting Anthropology Back Togueder Again: The Ethnogenetic Critique of Cladistic Theory *American Anthropologist* 96(4):925-948.
- Moravian-Church. 1858-2009. *Moravian Church Records*. Rama Cay.
- Mordt M. 2002. *Sustento y Sostenibilidad en la Frontera Agrícola: La Evolucion de la Frontera Sudeste de Nicaragua*. Managua: Imprimatur Artes Graficas.
- Mueller KA. 1932. *Among Creoles, Miskito and Sumus*. Bethlehem, Pa: The Comenius press.
- Muller G. 2001. *Defending Rama Indian Community Lands and the Southeastern Biosphere Reserve*. Nicaragua: Four Directions Geographic Consulting (4DGC).
- Murillo M. 2009. *Social Change in Pre-Columbian San Ramon de Alajuela, Costa Rica, and its Relation with Adjacent Regions*. Pittsburg: University of Pittsburg.
- Nagy A. 2008. An Osteological Analysis of Ten Human Crania from Costa Rica. *Annals of the Carnegie Museum* 76(4):265-278.
- Neel J. 1978. The Population Structure of an Amerindian Tribe, The Yanomama. *Annual Review of Genetics* 12:365-413.
- Neel J. 1994. *Physician to the Gene Pool: Genetic Lessons and Other Stories*. New York: John Willey and Sons.
- Neel J, and Salzano FM. 1964. A Prospectus for Genetic Studies of the American Indians. *Quantitative Biology* 29:85-98.
- Neel J, and Salzano FM. 1967. Further Studies of the Xavante Indians.X. Some Hypotheses-generalizations Resulting for This Study. *American Journal of Human Genetics* 19:554-574.
- Nei M. 1987. *Molecular Evolutionary Genetics*. New York: Columbia University Press.
- Nettle D. 1999. Linguistic Diversity of the Americas can be Reconciled with a Recent Colonization. *Proc Natl Acad Sci* 96:3325-3329.
- Newson L. 1987. *Indian Survival in Colonial Nicaragua*. USA: The University of Oklahoma Press.
- Newton AP. 1913. *The Colonising Activities of the English Puritans: The Last Phase of the Elizabethan Struggle with Spain*. New Haven, CT: Yale University Press. 240 p.
- Nietschmann B. 1969. The Distribution of Miskito, Sumu, and Rama Indians, Eastern Nicaragua. *Bulletin of International Comitee on Urgent Anthropological and Ethnological Reseach* 11:91-102.
- Nietschmann B. 1972. Hunting and Fishing Focus Among the Miskito Indians, Eastern Nicaragua. *Human Ecology* 1(1):41-67.
- Nietschmann B. 1973. *Between Land and Water*. New York: Seminar Press.
- Nietschmann B, and Nietschmann J. 1974. Cambio y Continuidad de los Indígenas Rama de Nicaragua. *Boletín Nicaragüense de Bibliografía* 26:31-41.

- Norr L. 1991. Nutritional Consequences of Pre-Historic Subsistence Strategies in Lower Central America. Champaign-Urbana: University of Illinois.
- North KE, and Crawford MH. 1996. Isonymy and Repeated Pairs Analysis: The Mating Structure of Acceglia, 1889-1968. *Rivista di Antropologia (Roma)* 74:96-103.
- Nuñez C, Baeta M, Sosa C, Casalod Y, Ge J, Budowle B, and Martínez-Jarreta B. 2010. Reconstructing the Population History of Nicaragua by means of mtDNA, Y-Chromosome STRs, and Autosomal STR Markers. *American Journal of Physical Anthropology* 143(4):591-600.
- O'Rourke DH, Hayes MG, and Carlyle SW. 2000. Spatial and Temporal Stability of mtDNA Haplogroup Frequencies in Native North America. *Human Biology* 72:15-34.
- Obando P. 1995. Childhood Stress and Bone Maintenance in Pre-Historic Northwestern Costa Rica: An Analysis of Two Coastal Populations, Nacascolo and Vidor. Boulder: University of Colorado.
- Offen KH. 1999. The Miskitu Kingdom Landscape and Emergence of a Miskitu Ethnic Identity, Northeastern Nicaragua and Honduras, 1600-1800. Austin: University of Texas.
- Offen KH. 2002. The Sambo and Tawira Miskitu: The Colonial Origins and Geography of Intra-Miskitu Differentiation in Eastern Nicaragua and Honduras. *Ethnohistory* 49:319-372.
- Olien MD. 1988. After the Indian Slave Trade: Cross-Cultural Trade in the Western Caribbean Rimland, 1816-1820. *Journal of Anthropological Research* 44(1):41-66.
- Olivier J. 2011. Foreword. In: Hofman C, and Van-Duijvenbode A, editors. *Communities in Contact: Essays in Archaeology, Ethnohistory, Etnography of the Amerindian Circum-Caribbean*. Laiden: Sidestone Press. p 9-12.
- Ordones J, Hing A, and Mullis R. 1998. Censo Socio Económico de la Comunidad Rama Cay. Proyecto DIRAL. Convenio Holanda/Nicaragua, MEDE/PESCA,RAAS.
- P.R.O.F.O. 1841. List of Grants 53/44. Fol. 128-188. London: Public Records Office F.O.
- PAHO. 2003. Nicaragua. *Epidemiological Bolletin*. p 20-23.
- PAHO. 2007. Health in the Americas: Nicaragua. p 504-531.
- PAHO. 2009. Heath Systems Profile Nicaragua: Monitoring and Analyzing Heath Systems Change. Washington, D.C: HSS/HP.USAID.
- Palumbo S. 2009. The Development of Complex Society in the Volcan Baru Region of Western Panama. Pittsburgh: University of Pittsburgh.
- Pavard S, Koons D, and Heyer E. 2007. The Influence of Maternal Care in Shaping Human Survival and Fertility. *Evolution* 61(12):2801-2810.
- Pearson GA. 2002. Pan-Continental Peleoindian Expansions and Interactions as Viewed from the Earliest Lithic Industries of Lower Central America [Ph.D. Dissertation]. Lawrence: University of Kansas.
- Pearson GA. 2003. First Report of a Newly Discovered Paleoindian Quarry site on the Isthmus of Panama. *Latin American Antiquity* 14(3):311-322.
- Peralta MM. 1883. Costa Rica, Nicaragua y Panamá en el siglo XVI, su Historia y sus Limites según los Documentos del Archivo de la Indias de Sevilla, del de Simancas etc., Recogidos y Publicados con Notas y Aclaraciones Históricas y Geográficas. Madrid: Librería de M. Murillo.
- Peralta MM. 1886. Costa Rica y Colombia de 1573 a 1881. Su Jurisdicción y sus Límites Territoriales según los Documentos Inéditos del Archivo de las Indias de Sevilla y otras Autoridades. París: Librería de M. Murillo.

- Peralta MM. 1898. *Costa Rica y Costa de Mosquitos: Documentos para la Historia de la Jurisdicción Territorial de Costa Rica y Colombia*. París: D. Manuel M. de Peralta.
- Perego UA, Achilli A, Angerhofer N, Accetturo M, Pala M, Olivieri A, Hooshiar Kashani B, Ritchie KH, Scozzari R, Kong QP et al. 2009. Distinctive Paleo-Indian Migration Routes from Beringia Marked by Two Rare mtDNA Haplogroups. *Curr Biol* 19:1-8.
- Perego UA, Lancioni H, Tribaldos M, Angerhofer N, Ekins JE, Olivieri A, Woodward SR, Pascale JM, Cooke R, Motta J et al. . 2012. Decrypting the Mitochondrial Gene Pool of Modern Panamanians. *PLoS ONE* 7(6):e38337.
- Perez-Brignoli H. 2005. La Dinámica Demográfica de las Poblaciones Indígenas del Trópico Húmedo de América Central (censos 2000). IUSSP XXVth International Population Conference. Tours, France, 18-23 July.
- Petersen DD, Kong AN, Jorge LF, Nebert DW, and Arias TD. 1991. Debrisoquine Polymorphism: Novel CYP2D6 Gene Bam HI Restriction Fragment Length Polymorphism in the Ngawbé Guaymí Indian of Panama. *Pharmacogenetics* 1(3):136-142.
- Pim Bc, and Seeman B. 1869. *Dottings on the Roadside in Panama, Nicaragua and Mosquitia*. London: Chapman and Hall.
- Pinto-Cisneros J, Pineda L, and Barrai I. 1985. Estimation of Inbreeding by Isonymy in Iberoamerican Populations: An Extension of the Method of Crow and Mange. *American Journal of Human Genetics* 37:373-385.
- Piperno D. 2006a. The Origin of Plant Cultivation and Domestication in the Neotropics. In: Douglas KJ, and Winterhalder B, editors. *Behavioral Ecology and the Transition to Agriculture*. London: University of California Press. p 137-166.
- Piperno D. 2006b. *Phytoliths: A Comprehensive Guide for Archaeologists and Paleoecologists*. Lanham, MD: AltaMira Press.
- Piperno D. 2011. The Origins of Plant Cultivation and Domestication in the New World Neotropics: Patterns, Process, and New Developments. *Current Anthropology* 52(S4):453-470.
- Piperno D, and Jones JG. 2003. Paleoecological and Archaeological Implications of the Late Pleistocene/Early Holocene Record of Vegetation and Climate Change from the Pacific Coastal Plain of Panama. *Quaternary Research* (59):79-86.
- Piperno D, and Pearsall DM. 1998. *The Origins of Agriculture in the Lowlands Neotropics*. San Diego: Academic Press.
- Pittier H. 1938. *Capítulos Escogidos de la Geografía Física de Costa Rica*. San José: Museo Nacional de Costa Rica.
- Popoff C, and Judson DH. 2004. Some Methods of Estimation for Statistically Underdeveloped Areas. In: Siegel JS, and Swanson DA, editors. *The Methods and Materials of Demography*. London, UK: Elsevier Academic Press. p 602-641.
- Post R, Neel JV, and Schull WJ. 1968. *Tabulations of Phenotype and Gene Frequencies of 11 Different Genetic Systems Studied in the American Indian*. Biomedical Challenges Presented by the American Indian. Washington, D.F.: PAHO.
- Pucciarelli HM, González J, Neves WA, Sardi M, and Ramírez F. 2008. East-West Cranial Differentiation in Pre-Columbian Population from Central and South America. *Journal of Human Evolution* 54:296-308.



- Pucciarelli HM, Neves WA, Gonzalez R, Ramirez F, Struck A, and Bonilla MY. 2006. East-West Cranial Differentiation in Pre-Columbian Human Population of South America. *Homo* 57:133-150.
- Quesada M, and Barrantes R. 1983. Dermatoglifos en dos Poblaciones Indígenas Guaymí de Costa Rica. *Revista de Biología Tropical* 31:269-275.
- Quesada M, and Barrantes R. 1986. Rasgos Dermatoglíficos de los Indígenas de Boruca, Costa Rica. In: Barrantes R, Bozzoli ME, and Gudino P, editors. *Memorias del Primer Simposio Científico sobre Pueblos Indígenas de Costa Rica*. San José, C.R.: Instituto Geográfico Nacional.
- Quesada M, and Barrantes R. 1991. Dermatoglifos en los Amerindios Bribri y Cabecar de Costa Rica. *Revista de Biología Tropical*: 63-70.
- R P. 2011. The R Foundation for Statistical Computing. Platform: i386-pc-mingw32/i386 (32-bit). 2.13.1 ed.
- Radell D. 1976. The Indian Slave Trade and Population in Nicaragua During the Sixteenth Century. In: Denevan W, editor. *The Native Population of the Americas in 1492*. Madison: University of Wisconsin Press. p 67-76.
- Rains DW. 1997. Central American Landscapes. In: Coates AG, editor. *Central America: A Natural History*. Ann Arbor, Michigan: Yale University Press. p 72-96.
- Ramenofsky A, Wilbur A, and Stone A. 2003. Native American Disease History: Past, Present and Future Directions. *World Archaeology* 35(2):241-257.
- Ramos-Onsins SE, and Rozas J. 2002. Statistical Properties of New Neutrality Tests Against Population Growth Molecular Biology and Evolution 19:2092-2100.
- Ranere AJ, and Cooke RG. 1991. Paleoindian Occupation in the Central American Tropics. In: Bonnicksen R, and Tummire KL, editors. *Clovis Origins and Adaptations*. Corvallis: Center for the Study of the First Americans, Oregon State University. p 237-253.
- Rapoport A. 2002. Spatial Organization and the Built Environment. In: Ingold T, editor. *Companion Encyclopedia of Anthropology*. New York: Routledge. p 460-502.
- Records MC. 1858-2009. Rama cay: Moravian Church.
- Reddy BM, Chopra VP, and Malhorta KC. 1987. Opportunity for Natural Selection with Special Reference to Population Structural Measures among the Vaddie. *Annals of Human Biology* 14(3):249-261.
- Reich D, Patterson N, Campbell D, Tandon A, Mazieres S, Ray N, Parra MV, Rojas W, Duque C, Mesa N et al. 2012. Reconstructing Native American Population History. *Nature* 488(7411):370-374.
- Relethford JH. 1988. Estimation of Kinship and Genetic Distance from Surnames. *Human Biology* 60:475-492.
- Relethford JH. 2012. *Human Population Genetics*. New Jersey: Wiley-Blackwell.
- Reynolds J, Weir BS, and Cockerham CC. 1983a. Estimation for the Coancestry Coefficient: Basis for a Short-Term Genetic Distance. *Genetics* 105:767-779.
- Reynolds J, Weir BS, and Cockerham CC. 1983b. Estimation for the Coancestry Coefficient: Basis for a Short-term Genetic Distance. *Genetics* 105:767-779.
- Rickards O, Martinez-Labarga C, Lum JK, De Stefano GF, and Cann RL. 1999. mtDNA History of the Cayapa Amerinds of Ecuador: Detection of Additional Founding Lineages for the Native American Populations. *American Journal of Human Genetics* 65(2):519-530.
- Riverstone G. 2004. *Living in the Land of Our Ancestors*. Managua: Imprimatur.

- Riverstone G. 2006. The Political Ecology of Indigenous Land Tenure in Caribbean Nicaragua: Crisis and Opportunity in Rama Indian Territory. In: González M, Jentoft S, Koskinen A, and Lopez D, editors. *The Rama People Struggling for Land and Culture*. Bluefields: URACCAN.
- Roberts DF. 1980. Current Developments in Anthropological Genetics: Achievements and Gaps. In: Mielke JH, and Crawford MH, editors. *Current Developments in Anthropological Genetics: Vol 1 Theories and Methods*. New York: Plenum Press. p 419-430.
- Roberts DF. 1993. Collection of Human Population Data. In: Lasker GW, and Masie-Taylor CGN, editors. *Research Strategies in Human Biology: Field and Survey Methods*. Cambridge: Cambridge University Press. p 92-107.
- Roberts O. 1978 [1827]. *Narración de los Viajes y Excursiones en la Costa Oriental y el Interior de Centroamérica*. Nicaragua: Banco de América.
- Rodríguez-Larralde A. 1993. Genetic Distance Estimated Through Surname Frequencies of 37 Counties from the State of Lara, Venezuela. *Journal of Biosocial Science* 25(1):101-110.
- Rodríguez-Larralde A, Dipierri J, Alfaro-Gomez E, Scapoli C, Mamolini E, Salvatorelli G, De Lorenzi S, Carrieri A, and Barraí I. 2011. Surnames in Bolivia: A Study of the Population of Bolivia Through Isonymy. *American Journal of Physical Anthropology*(144):177-184.
- Rodríguez-Larralde A, Scapoli C, Beretta M, Nesti C, Mamolini E, and Barraí I. 1998. Isonymy and the Genetic Structure of Switzerland. II. Isolation by Distance. *Annals of Human Biology* 25:533-540.
- Rodríguez R, Watson ME, Lopez JB, Herrera E, Miranda A, Zeledon A, Diaz B, and Rodriguez M. 2007. Biogeografía de la Costa Caribe Nicaragüense. In: Romela Arrechavala J, editor. *Historia de la Costa del Caribe de Nicaragua*. Managua: UNAN, Agencia Asturiana de Cooperación y Desarrollo. p 17-55.
- Rodríguez Ramos R, and Hofman C. 2009. Vínculos Transoceánicos en el Caribe Precolombino. *Vínculos* 32:89-106.
- Rogers AR. 1987. A Model of Kin-Structured Migration. *Evolution* 41(2):417-426.
- Rogers AR, and Harpending H. 1992. Population Growth Makes Waves in the Distribution of Pairwise Genetic Differences. *Molecular Biology and Evolution* 9:552-669.
- Rohlf F. 2002. *NTSYSpc: Numerical Taxonomy System*. 2.11s ed. New York: Setauket. Exeter Publishing.
- Roethford J. 2007. The Use of Quantitative Traits in Anthropological Genetics Studies of Population Structure and History In: Crawford MH, editor. *Anthropological Genetics: Theory, Methods, and Applications*. Cambridge, UK: Cambridge University Press.
- Romero G. 1995. *Las Sociedades del Atlántico de Nicaragua en los Siglos XVII y XVIII*. Managua: Colección Cultural Banco Nicaragüense.
- Romero G. 1996. *Historia de la Costa Atlántica*. Managua: CIDCA-EDUCA.
- Romero J. 2007. *Historia del la Costa del Caribe de Nicaragua*. Managua: EDITASA.
- Roosevelt AC, Douglas J, and Brown L. 2002. The Migrations and Adaptations of the First Americans Clovis and Pre-clovis Viewed from South America. In: Jablonsky NG, editor. *The First Americans*. San Francisco, CA: University of California Press.
- Rosemblat A. 1954. *La Población Indígena y el Mestizaje en América*. Buenos Aires: Editorial Nova.
- Rousham E, and Humphrey L. 2002. The Dynamics of Child Survival. In: Macbeth H, and Collinson P, editors. *Human Population Dynamics*. Cambridge: Cambridge University Press. p 124-140.

- Rubicz RC, Melton PE, and Crawford MH. 2007. Molecular Markers in Anthropological Genetic Studies. In: Crawford MH, editor. *Anthropological Genetics*. New York: Cambridge University Press. p 141-186.
- Ruiz-Narvaez EA, Santos FR, Carvalho-Silva Dd, Azofeifa J, Barrantes R, and Pena SD. 2005. Genetic Variation of the Y Chromosome in Chibcha-Speaking Amerindians of Costa Rica and Panama. *Human Biology* 77(1):71-91.
- Sáez-Llorens X, and McCracken GH. 2003. Bacterial Meningitis in Children. *Lancet* 361(9375):2139-2148.
- Saillard J, Foster P, Lynnerup N, Bandelt HJ, and Norby S. 2000. mtDNA Variation Among Greenland Eskimos: The Edge of the Beringian Expansion. *American Journal of Human Genetics* 63(3):718-726.
- Saitou N, and Nei M. 1987. The Neighbor-joining Method: A New Method for Reconstructing Phylogenetic Trees. *Molecular Biology and Evolution* 4(4):406-425.
- Salas A, Lovo-Gómez J, Álvarez-Iglesias V, Cerezo M, Lareu MV, Macaulay V, Richards MB, and Carracedo Á. 2009. Mitochondrial Echoes of First Settlement and Genetic Continuity in El Salvador. *PLoS ONE* 4(9):e6882.
- Salas A, Richards M, Lareu M, Sobrino B, Silva S, Matamoros M, Macaulay V, and Carracedo A. 2005. Shipwrecks and Founder Effects: Divergent Demographic Histories Reflected in Caribbean mtDNA. *Am J Phys Anthropol* 128:855-860.
- Salgado S. 1996. *Social Change in a Region of Granada, Pacific Nicaragua (1000 B.C.-1522 A.D.)*. Albany: State University of New York.
- Salgado S, and Fernández-León E. 2011. Elementos para el Estudio de una Migración Antigua: El caso de los Chorotega-Mangue. *Cuadernos de Antropología* 21:1-30.
- Salgado S, Niemel K, and Lacayo MR. 2007. Cambios Sociales en la Historia Antigua en la Zona de Granada y Masaya, Pacífico de Nicaragua. *Arqueología del Área Intermedia* 7:137-159.
- Salgado S, and Vasquez R. 2006. Was There a Greater Nicoya Subarea during the Post-Classic? *Vinculos* 29(1-2):1-16.
- Sandoval K, Buentello-Malo L, Pen˜aloza-Espinosa R, Avelino H, Salas A, Calafell F, and Comas D. 2009. Linguistic and Maternal Genetic Diversity are not Correlated in Native Mexicans. *Human Genetics* 126:521-531.
- Sanna E, Iovine MC, Melis M, and Floris G. 2006. Lasker's Coefficient of Isonymy Between and within 16 Sardinian Villages in the Periods 1825-1849, 1875-1899, and 1925-1949. *American Journal of Human Biology* 18(5): 621-629.
- Santos M, and Barrantes R. 1994. Direct Screening of a Mitochondrial DNA Deletion Valuable for Amerindian Evolutionary Research. *Human Genetics* 93: 435-436.
- Santos M, Ward RH, and Barrantes R. 1994. mtDNA Variation in the Chibchan Amerindian Huetaar from Costa Rica. *Human Biology* 66: 963-977.
- Sapper K. 1924. Die zahl und Die Völkische Der Indianischen Bevölkerung in Amerika. *La Haya: XXI Congreso Internacional de Americanistas*. p 95-104.
- Sauer C. 1966. *The Early Spanish Man*. Berkeley: University of California Press.
- Scapoli C, Mamolini E, Carrieri A, Rodriguez-Larralde A, and Barrai I. 2006. Surnames in Western Europe: A Comparison of the Subcontinental Populations through Isonymy. *Theoretical Population Biology* 71:37-48.

- Scheffler T, Hirth K, and Hasemann G. 2012. The El Gigante Rockshelter: Preliminary Observations on an Early to Late Holocene Occupation in Southern Honduras. *Latin American Antiquity* 23(4):597-610.
- Schiffer MB. 1996. Formation processes of the archaeological record. Salt Lake city, Utah: University of Utah Press.
- Schnaider R. 1989. Rama and the Sandinist Revolution. Berlin: Dietrich Reimer Verlag.
- Schneider R. 1989. Rama and the Sandinist Revolution. Berlin: Dietrich Reimer Verlag.
- Schneider S, Roessli D, and Excoffier L. 2000. Arlequin ver. 2.00: A Software for Population Genetic Data Analysis. Switzerland: Genetics and Biometry Laboratory, University of Geneva.
- Schultz AH. 1926. Anthropological Studies of the Nicaraguan Indians. *American Journal of Physical Anthropology* 9:65-79.
- Schurr G, Ballinger SW, Gan YY, Hodge JA, Merriwether DA, Lawrence DN, Knowler WC, Weiss K M, and Wallace DC. 1990. Amerindian mitochondrial DNAs have rare Asian mutations at high frequencies, suggesting they derived from four primary maternal lineages. *American Journal of Human Genetics* 46(3):613-623.
- Schurr TG. 2010. Coastal Waves and Island Hopping. In: Fitzpatrick S, and Ross AH, editors. *Island Shores, Distant Pasts*. Gainesville: University Press of Florida. p 177-197.
- Service ER. 1962. *Primitive Social Organization: An Evolutionary Perspective*. New York: Random House.
- Sheets P. 1994. Chipped Stone Artifacts from the Cordillera de Tilaran. In: Sheets P, editor. *Archaeology, Volcanism, and Remote Sensing in the Arenal Region of Costa Rica*. Austin: University of Texas Press.
- Sheets P, and McKee BR. 1994. *Archaeology, Volcanism, and Remote Sensing in the Arenal Region, Costa Rica*. Austin: University of Texas Press.
- Sherman W. 1979. *Forced Native Labor in Sixteenth-century Central America*. Lincoln: University of Nebraska Press.
- Smouse PE, Long JC, and Sokal RR. 1986. Multiple Regression and Correlation Extensions of the Mantel Test of Matrix Correspondence. *Systematic Zoology* 35(4):627-632.
- Smutko G. 1988. La Mosquitia. Managua, Nicaragua: Editorial La Ocarina.
- Snarskis M. 1978. *The Archaeology of the Central Atlantic Watershead of Costa Rica*. New York: Columbia University.
- Snarskis M. 1979. Turrialba: A Paleoindian Quarry and Workshop of Costa Rica. *American Antiquity* 44(1):125-138.
- Snarskis M. 1981. The Archaeology of Costa Rica. In: Abel-Vidor S, editor. *Between Continents/between Seas: Precolumbian Art of Costa Rica*. New York: The Detroit Institute of Art, H.N. Abrams. p 15-84.
- Snarskis M. 1992. Wealth and Hierarchy in the Archaeology of Eastern and Central Costa Rica. In: Lange FW, editor. *Wealth and Hierarchy in the Intermediate Area*. Washington D.C.: *Dumbarton Oaks*. p 141-164.
- Sol F. 2002. Nuevas Perspectivas Sobre la Arqueología del Caribe Sur de Costa Rica. *Vínculos* 27:19-44.
- Solórzano JC. 2000. Los Indígenas en las Áreas Fronterizas de Costa Rica durante el Siglo XIX. *Avances de Investigación, Centro de Investigaciones Históricas* 78:1-39.
- Solórzano JC, and Fonseca E. 2006. *Costa Rica en el Siglo XVI: Descubrimiento, Explotación y Conquista*. San José: Editorial UCR.

- Spielman RE, Neel JV, Gershowitz H, and Torrez de Arauz R. 1979. The Evolutionary Relationship of Two Populations: A study of the Guaymi and Yanomama. *Current Anthropology* 20:377-388.
- Spinden HJ. 1917. The Origin and Distribution of Agriculture in America. Proceedings of the 19th International Congress of Americanists, 1915. Washington.
- Squier EG. 1891. *Adventures on the Mosquito Shore*. New York: Worthington Co.
- Steele J, and Shennan S. 2009. Introduction: Demography and Cultural Macroevolution. *Human Biology* 81 (2-3):105 -119.
- Steward JH. 1948. The Circum-Caribbean Tribes: An Introduction. In: 143 SIBoAEB, editor. *Handbook of South American Indians*. Wasington DC. p 1-43.
- Steward JH, and Faron LC. 1959. *Native Peoples of South America*. York, PA: McGraw-Hill
- Stirling M. 1953. Hunting Prehistory in Panama Jungles. *National Geographic* p271-290.
- Stirling M, and Stirling M. 1964. Archaeological Notes on Almirante Bay, Bocas del Toro, Panama. Bureau of American Etnology, *Anthropological Papers*. Washington: Smithsonian Institution. p 255-284.
- Stone D. 1966. Synthesis of Lower Central America Ethnohistory. In: Ekhlon GF, and Willey GR, editors. *Handbook of Middle American Indians*. Austin: University of Texas Press. p 209-233.
- Stone D. 1972. Pre-columbinan Man Find Central America. *The Archalological Bridge*. Cambridge: Peabody Museum Press.
- Stone DZ. 1984. A History of Lower Central American Archaeology. In: Lange FW, and Stone DZ, editors. *The Archaeology of Lower Central America* Albuquerque: University of New Mexico Press p12-32.
- Sturrock K, and Rocha J. 2000. A Multidimensional Scaling Stress Evaluation Table. *Field Methods* 12:49-60.
- Swadesh M. 1955a. Time Depths of American Linguistic Groupings. *American Anthropologist* 56(121-137).
- Swadesh M. 1955b. Toward Greater Accuracy in Lexicostatistic Dating. *American Journal of Linguistics* 21:121-137.
- Swauger JL, and Mayer-Oakes W. 1952. A Fluted Point from Costa Rica. *American Antiquity* 17(3):264-265.
- Sweeney JW. 1976. Ceramic Analysis from 3 Sites in Northwest Coastal Guanacaste. *Vínculos* 2:1 37-44.
- Tabachnick BG, and Fidell LS. 2001. *Using Multivariate Statistics*. Boston: Allyn and Bacon. 966 p.
- Tajima F. 1989. Statistical Method for Testing the Neutral Mutation Hypothesis by DNA Polymorphisms. *Genetics* 123:585-595.
- Tajima F. 1996. Infinite-allele Model and Infinite-site Model in Population Genetics. *Journal of Genetics* 75(1):27-31.
- Tamm E, Kivisild T, Reidla M, Metspalu M, Smith DG, Mulligan CJ, Bravi CM, Rickards O, Martinez-Labarga C, Khusnutdinova EK et al. . 2007. Beringian Standstill and Spread of Native American Founders. *PLoS ONE* 2(9):e829.
- Tamura K, and Nei M. 1993. Estimation of the Number of Nucleotide Substitutions in the Control Region of Mitochondrial DNA in Humans and Chimpanzees. *Molecular Biology and Evolution* 10(3):512-526.

- Tanis RN, Neel JV, and Torrez de Arauz R. 1977. Two More Private Polymorphisms of American Tribes: LDH GUA-1 and ACP-GUA -1 in the Guaymi of Panama. *American Journal of Human Genetics* 29:419-430.
- Thompson EA, Neel JV, Smouse PE, and Barrantes R. 1992. Microevolution of the Chibcha-speaking of Lower Central America: Rare Genes in an Amerindian Complex. *American Journal of Human Genetics* 51:609-626.
- Thompson VD, and Worth JE. 2011. Dwellers by Sea: Native Americans Adaptations Along the Southern Coasts of Eastern North America. *Journal of Archaeological Research* 19:51-101.
- Tishkoff SA, and Gonder MK. 2007. Human Origins within and Out of Africa. In: Crawford MH, editor. *Anthropological Genetics: Theory, Methods and Applications*. Cambridge: Cambridge University Press. p 337-379.
- Torben RC, and Erlandson JM. 2009. Coastal Exploitation. *Science* 235:952-953.
- Torquemada J. 1975 [1615]. *Monarquía Indiana*. Mexico: Universidad Autónoma de México.
- Torróni A, Neel JV, Barrantes R, Schurr TG, and Wallace DC. 1994. Mitochondrial DNA "Clock" for the Amerinds and its Implications for Timing Their Entry into North America. *PNAS* 91(3):1158-1162.
- Torróni A, Schurr TG, Cabell MF, Brown MD, Neel JV, Larsen M, Smith DG, Vullo CM, and Wallace DC. 1993. Asian Affinities and Continental Radiation of the Four Founding Native American mtDNAs. *American Journal of Human Genetics* 53(3):563-590.
- Tous Mata M. 2002. *De la Gran Nicoya Precolombina a la Provincia de Nicaragua, s. XV y XVI*. Barcelona: Universitat de Barcelona.
- Underhill PA, and Kivisild T. 2007. Use of Y Chromosome and Mitochondrial DNA Population Structure in Tracing Human Migrations. *Annual Review of Genetics* 41:539-564.
- Valerio W. 2000. Informe de Laboratorio: Análisis Lítico. Excavaciones de Rescate en el Sitio Finca Guardiaria (C-9FG), Turrialba, Áreas Arqueológicas II,III,V. San José, Costa Rica: Departamento de Antropología e Historia.MNCR.
- van Oven M. 2010. Revision of the mtDNA Tree and Corresponding Haplogroup Nomenclature. *PNAS* 107(11):E38-E39
- van Oven M, and Kayser M. 2009. Updated Comprehensive Phylogenetic Tree of Global Human Mitochondrial DNA Variation. *Human Mutat* 30(2):E386-E339.
- Vandaele W. 1983. *Applied Time Series and Box-Jenkins Models*. NY: Accademic Press Inc.
- Vasquez R, Rojas M, Chacón A, Hidalgo T, and Bertheu M. 1993. Banco Unificado de Datos de Sitios Arqueológicos y su Estado de Investigación. San José: Museo Nacional de Costa Rica.
- Vasquez RL. 1984. Estructura e Integración y Composición Demográfica en un Cementerio de Tumbas de Cajón del Intermontano Central de Costa Rica. In: Skirboll E, and Creamer W, editors. *Inter-Regional Ties in Costa Rican Prehistory*. Oxford: BAR International Series 226. p 56-81.
- Vásquez RL, and Weaver DS. 1980. Un Análisis Osteológico para el Reconocimiento de las Condiciones de Vida del Sitio Vidor. *Vínculos* 15:1-23.
- Ventura R. 2003. Indigenous Peoples, Changing Social and Political Landscapes, and Human Genetics in the Amazonia. In: Goodman A, Heath D, and Lindee SM, editors. *Genetic Nature/Culture: Anthropology and Science Beyond the Two-Culture Divide*. London: University of California Press. p 23-40.

- Von Oerstzen RL, and Wunderrich V. 1990. *The Nicaraguan Mosquitian Historical Documents 1844-1927*. Germany: Dietrich Reimer Verlag.
- Wake T, Mojica A, Davis M, Campbell C, and Mendizabal T. 2012. Electrical Resistivity Surveying and Pseudo-Three-Dimensional Tomographic Imaging at Sitio Drago, Bocas del Toro, Panama. *Archaeological Prospection* 19:49-58.
- Wake TA. 2006. Prehistoric Exploitation of the Palm Swamp (*Raphia taedigera*: Arecaceae) at Sitio Drago, Isla Colon, Bocas del Toro Province, Panama. *Caribbean Journal of Science* 42(1):11-19.
- Wake TA, de Leon J, and Fitzgerald B. 2004. Prehistoric Sitio Drago, Bocas del Toro, Panama. *Antiquity* 78(300):1-6.
- Wallace DC, and Torroni A. 1992. American Indian Prehistory as Written in Mitochondrial DNA: A Review. *Human Biology* 63(3):403-416.
- Wang M, and Barrantes R. 2008. Dermatoglifos de los Amerindios Bribri y Cabecar de Costa Rica. *Revista de Biología Tropical* 39(1):63-70.
- Wang S, Lewis CM, Jr., Jakobsson M, Ramachandran S, Ray N, Bedoya G, Rojas W, Parra MV, Molina JA, Gallo C et al. . 2007. Genetic Variation and Population Structure in Native Americans. *PLoS Genetics* 3(11):e185.
- Ward RH, Frazier BL, Dew-Jager K, and Pääbo S. 1991. Extensive Mitochondrial Diversity within a Single Amerindian Tribe. *Proceedings of the National Academy of Sciences* 88(19):8720-8724.
- Webb RS, Rind DH, Lehman SJ, Healy RJ, and Sigman D. 1997. Influence of Ocean Heat Transport on the Climate of the Last Glacial Maximum. *Nature*(385):695-699.
- Weir JT, Bermingham E, and Schluter D. 2009 The Great American Biotic Interchange in Birds. *PNAS* (106):21737-21742.
- Weiss KM. 1998. Coming to Terms with Human Variation. *Annual Review of Anthropology* 27:273-300.
- West RC. 1964. The Natural Regions in Middle America. In: West RC, editor. *Handbook of Middle American Indians: Natural Environments and Early Cultures*. Austin: Texas Press. p 363-383.
- WHO. 1950. December. Official Records of the World Health Organization, No. 28, Third World Health Assembly, Geneva, 8 to 27 May 1950.
- Wickham HA. 1872. *Rough Notes of a Journey Through the Wilderness*. London.
- Wiley G. 1971. *An Introduction to American Archaeology*. New Jersey: Prentice Hall Anthropology Series.
- Williams SR, Chagnon NA, and Spielman RS. 2002. Nuclear and Mitochondrial Genetic Variation in the Yanomamo: A Test Case for Ancient DNA Studies of Prehistoric Populations. *American Journal of Physical Anthropology* 117(3):246-259.
- Williams W, editor. 1815. *The Journal of Llewellyn Penrose, a Seaman*. London: Taylor and Hersey.
- Wilson SM, Iceland HB, and Hester TR. 1998. Pre-ceramic Connections between Yucatan and the Caribbean. *Latin American Antiquity* 9(4):342-352.
- Wright S. 1921. System of Mating. *Genetics*(6):111-178.
- Wright S. 1943. Isolation by Distance. *Genetics* 28:114-138.
- Wright S. 1951. The Genetic Structure of Populations. *Annals of Eugenics* 15:323-354.
- Wright S. 1962. *Evolution and the Genetics of Populations, Vol. 2, The Theory of Gene Frequencies*. Chicago: University of Chicago Press.

- Zhang MQ. 1998. Statistical Features of Human Exons and Their Flanking Regions. *Human Molecular Genetics* 7(5):919-932.
- Zlojutro M, Rubicz R, Devor E, Spitsyn V, Makarov S, Wilson K, and Crawford MH. 2006. Genetic Structure of the Aleuts and Circumpolar Populations Based on Mitochondrial DNA Sequences: A Synthesis. *Am J Phys Anthropol* 129:446-464.



## APPENDIX 1.



11/8/2013  
HSCL #16735

Norberto Baldi  
Anthropology  
622 Fraser

The Human Subjects Committee Lawrence reviewed your research update application for project  
16735 Crawford/Justice/Baldi (ANTHRO) Native American Origins

and approved it through an expedited review process according to 45 CFR 46.110 (b)(2) minor changes (or no changes) in a previously approved project. Your project has continued approval to 8/2/2009. Approximately one month prior to 8/2/2009 HSCL will send you a Status Report request, which will be necessary for you to complete in order to obtain continued approval for the next twelve months. Please note that you must stop data gathering if you do not receive continued HSCL approval. Notify HSCL of any changes you wish to make during this approval period.

Please use the HSCL "approval stamp" on your consent forms. Just cut and paste. You may resize and reshape the text to fit your documents.

**Approved by the Human Subjects Committee Lawrence (HSCL)  
on 6/5/2008. HSCL approval expires one year from 8/2/2008.  
HSCL#16735**

If you complete your project before the renewal date, please notify HSCL. Thank you for providing us with this update information.

Sincerely,

A handwritten signature in cursive script that reads 'David M. Hann'.

David Hann  
HSCL Coordinator  
University of Kansas

Human Subjects Committee Lawrence  
Youngberg Hall | 2385 Irving Hill Road | Lawrence, KS 66045 | (785) 864-7429 | Fax (785) 864-5049 | [www.rcr.ku.edu/hsc](http://www.rcr.ku.edu/hsc)

## APPENDIX 2.

### Oral Consent Form

The Department of Anthropology at the University of Kansas supports the practice of protection for human subjects participating in research. The following information is provided for you to decide whether you wish to participate in the present study. You should be aware that even if you agree to participate, you are free to withdraw at any time without penalty.

We are conducting this study to reconstruct the origins and migrations among Native Americans in Central and South America, using molecular genetic information. This will entail your completion of a questionnaire and providing a cheek swab and mouth rinse. The questionnaire packet is expected to take approximately 30 minutes to complete. The biological sample will be used to extract DNA to be used solely to reconstruct the history of Central and South America. Only personnel working directly on this project will have access to the DNA and questionnaire.

The content of the questionnaires should cause no more discomfort than you would experience in your everyday life. Although participation may not benefit you directly, we believe that the information obtained from this study will help us gain a better understanding of evolution and population history of Central and South America. Your participation is solicited, although strictly voluntary. Your name will not be associated in any way with the research findings. If you would like additional information concerning this study before or after it is completed, please feel free to contact us by phone or mail.

Completion of the survey and supply of buccal and sputum sample indicates your willingness to participate in this project and that you are over the age of eighteen. If you have any additional questions about your rights as a research participant, you may call (785) 864-7429 or (785) 864-7385 or write the Human Subjects Committee Lawrence Campus (HSCL), University of Kansas, 2385 Irving Hill Road, Lawrence, Kansas 66045-7563, email [dhann@ku.edu](mailto:dhann@ku.edu) or [mdenning@ku.edu](mailto:mdenning@ku.edu).

**Approved by the Human Subjects Committee Lawrence (HSCL)  
on 6/5/2008. HSCL approval expires one year from 8/2/2008.  
HSCL#16735**

Sincerely,

Norberto Baldi.  
Principal Investigator  
Department of Anthropology  
1415 Jayhawk Blvd.  
622 Fraser Hall  
University of Kansas  
Lawrence, KS 66045, U.S.A.  
(785) 864-2606  
[ajustice@ku.edu](mailto:ajustice@ku.edu)

Michael Crawford, Ph.D.  
Faculty Supervisor  
Department of Anthropology  
1415 Jayhawk Blvd.  
622 Fraser Hall  
University of Kansas  
Lawrence, KS 66045, U.S.A.  
(785) 864-4170  
[crawford@ku.edu](mailto:crawford@ku.edu)

**Participant certification:**

I have read this consent and authorization form. I have had the opportunity to ask, and I have received answers to, any questions regarding the study. I understand that if I have any additional questions about my rights as a research participant, I may call (785) 864-7429 or (785) 864-7385 or write the Human Subjects Committee Lawrence Campus (HSCL), University of Kansas, 2385 Irving Hill Road, Lawrence, Kansas 66045-7563, email: [dhann@ku.edu](mailto:dhann@ku.edu) or [mdenning@ku.edu](mailto:mdenning@ku.edu)

**Certificación de participación:**

Yo he leído esta fórmula de consentimiento informado. Yo tuve la oportunidad de preguntar y he recibido las respuestas indicadas con respecto a este estudio. Yo entiendo que si tengo preguntas adicionales acerca de mis derechos como participante de la investigación, yo podré llamar al teléfono (785) 864-7429 o al (785) 864 7385, o escribir a Human Human Subjects Committee Lawrence Campus (HSCL), University of Kansas, 2385 Irving Hill Road, Lawrence, Kansas 66045-7563, email: [dhann@ku.edu](mailto:dhann@ku.edu) or [mdenning@ku.edu](mailto:mdenning@ku.edu)

I agree to take part in this study as a research participant  
Yo estoy de acuerdo en este estudio como participante de la investigación

---

Type print participant name

---

Date

---

Participant signature

---

By my signature I affirm that I am at least 18 years old and that I have received a copy of this consent and authorization form.

Con mi firma yo afirmo que tengo por lo menos 18 años de edad y que he recibido una copia de este consentimiento informado.

### APPENDIX 3.

No de

participante.....fecha.....entrevistador.....

#### General Information

Nombre:	Ubicación:	Residencia (aldea, ciudad):	Fecha de nacimiento:	Lugar de nacimiento:
Información para contactar:			Edad:	Idioma/etnicidad:

#### Esposo/a

Nombre de esposo/a:	Fecha de nacimiento:	Lugar de nacimiento:	Idioma/etnicidad:	Residencia (aldea, ciudad):
Edad <sup>1</sup> :	Vivo/muerto	Notas:		

<sup>1</sup> Edad o edad de defunción

#### Historia de la familia

Relaciones	Nombre	Fecha de nacimiento	Lugar de nacimiento	Idioma/etnicidad	Residencia (aldea, ciudad):	Vivo/muerto	Edad <sup>1</sup>
Madre							
Madre de su madre							
Madre de su padre							
Padre							
Madre de su padre							
Padre de su padre							

#### Hermanos/as

Nombre	Hombre/mujer	Medio hermano(a)? (S/N)	Fecha de nacimiento	Lugar de nacimiento	Idioma/etnicidad	Residencia (aldea, ciudad):	Vivo/muerto	Edad <sup>1</sup>	Madre	Padre

#### Hijos/as

Nombre	Hombre/mujer	Fecha de nacimiento	Lugar de nacimiento	Residencia (aldea, ciudad):	Casado/a (S/N)	Nombre de su esposo/a	Vivo/muerto	Edad <sup>1</sup>

APPENDIX 4.

Sumu Kat:

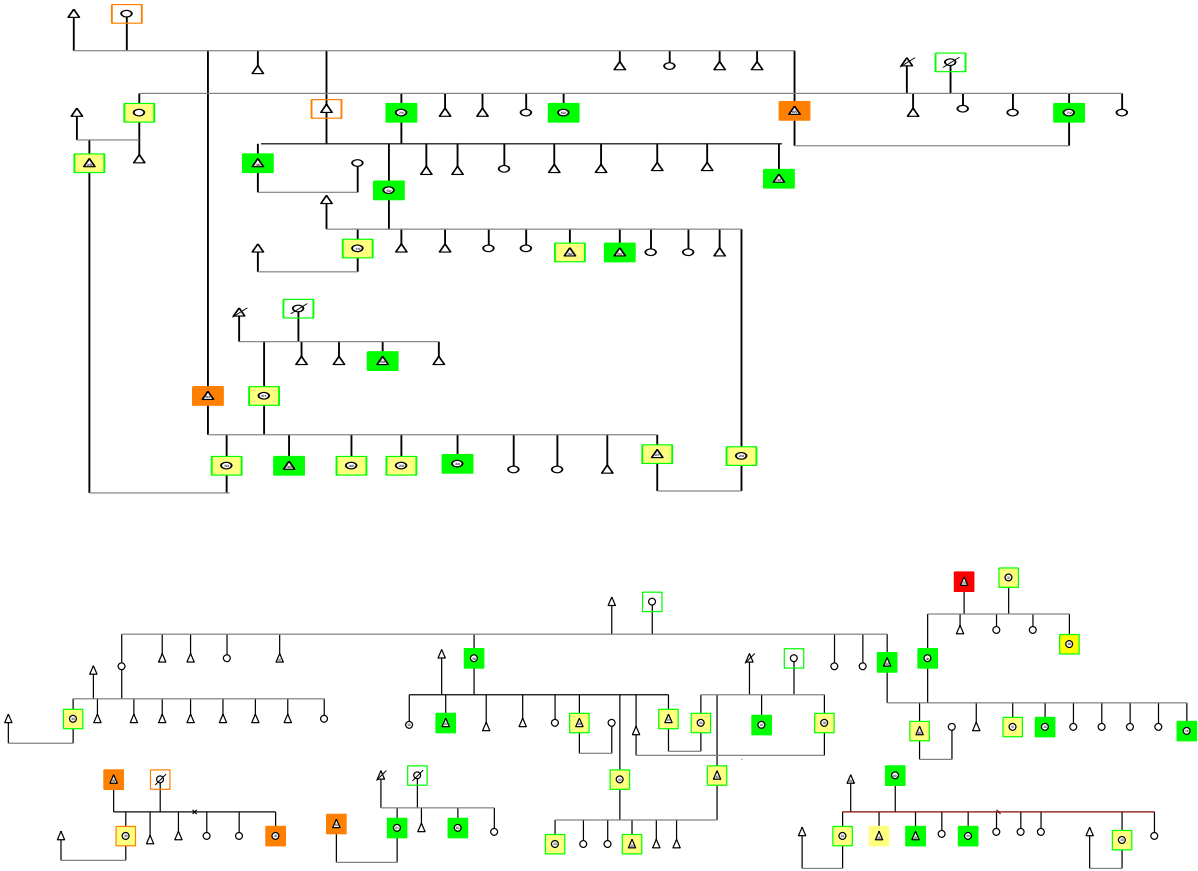

**Zompopera:**

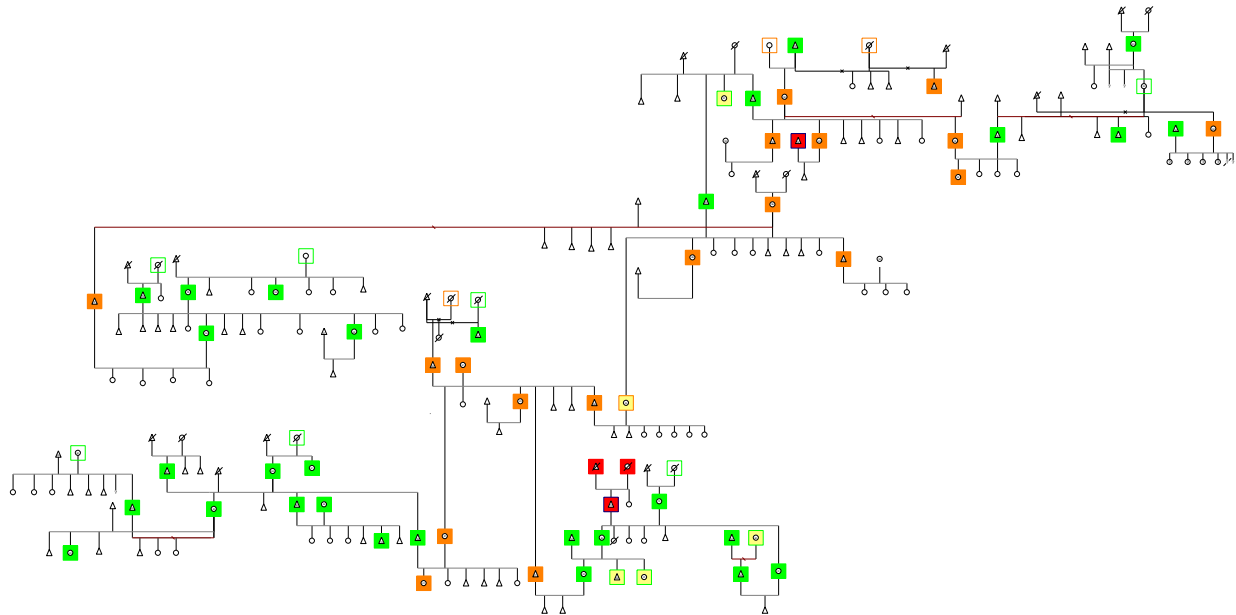

**Bluefields (Punta Fria):**

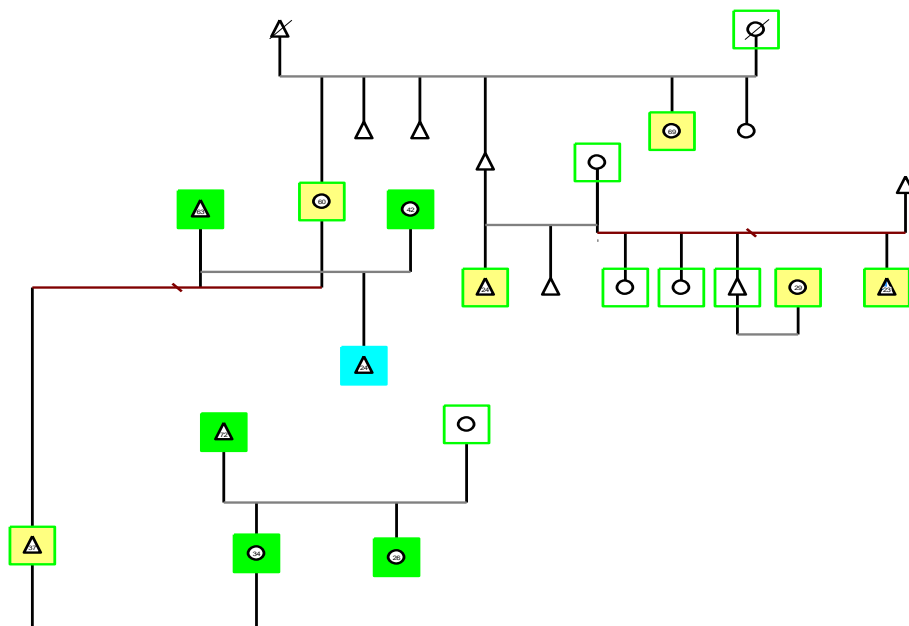

# Rama Cay:

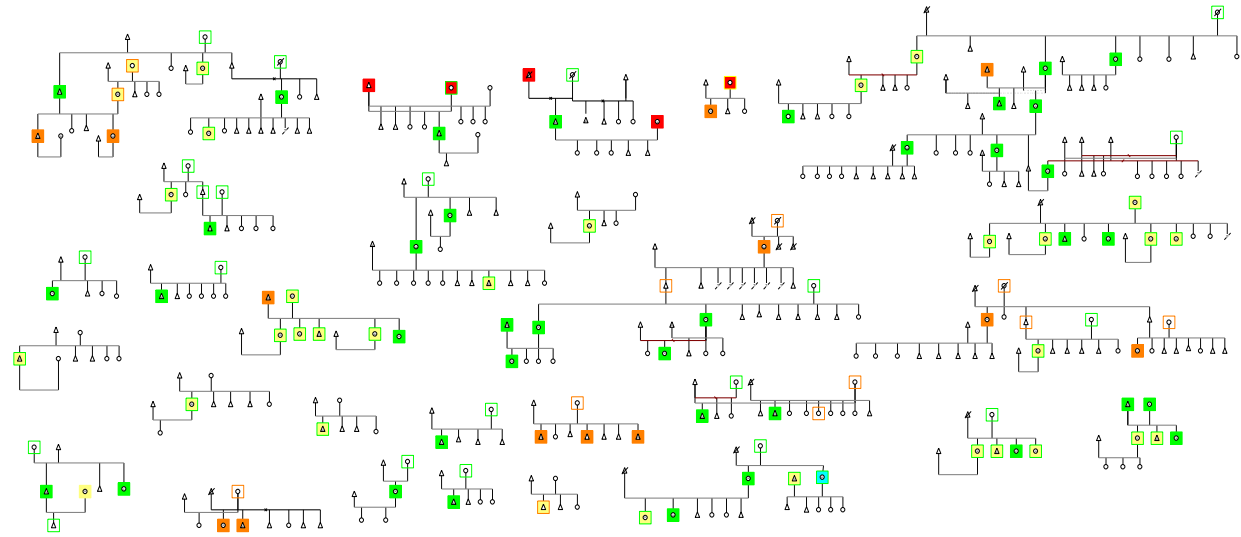
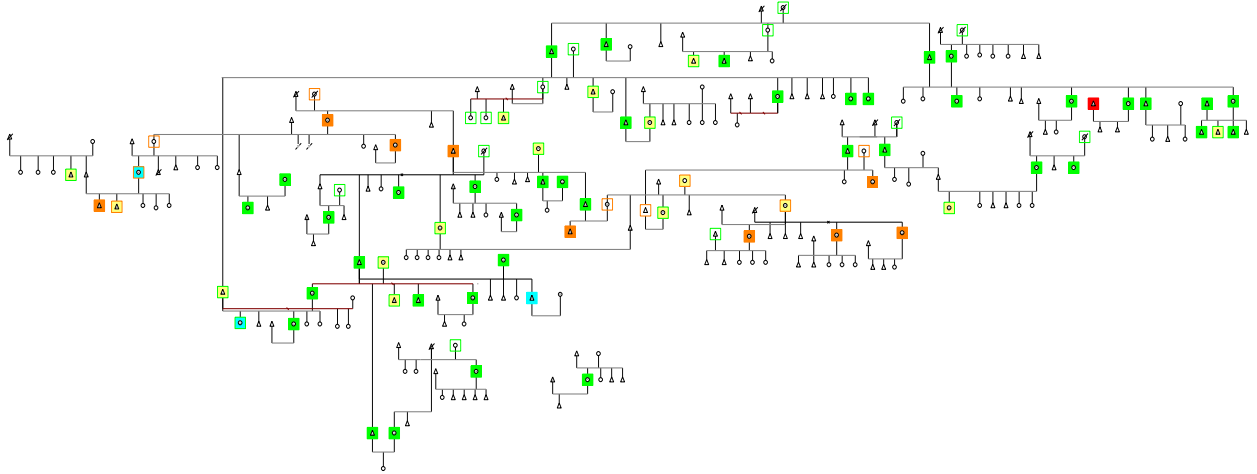

**Greytown:**

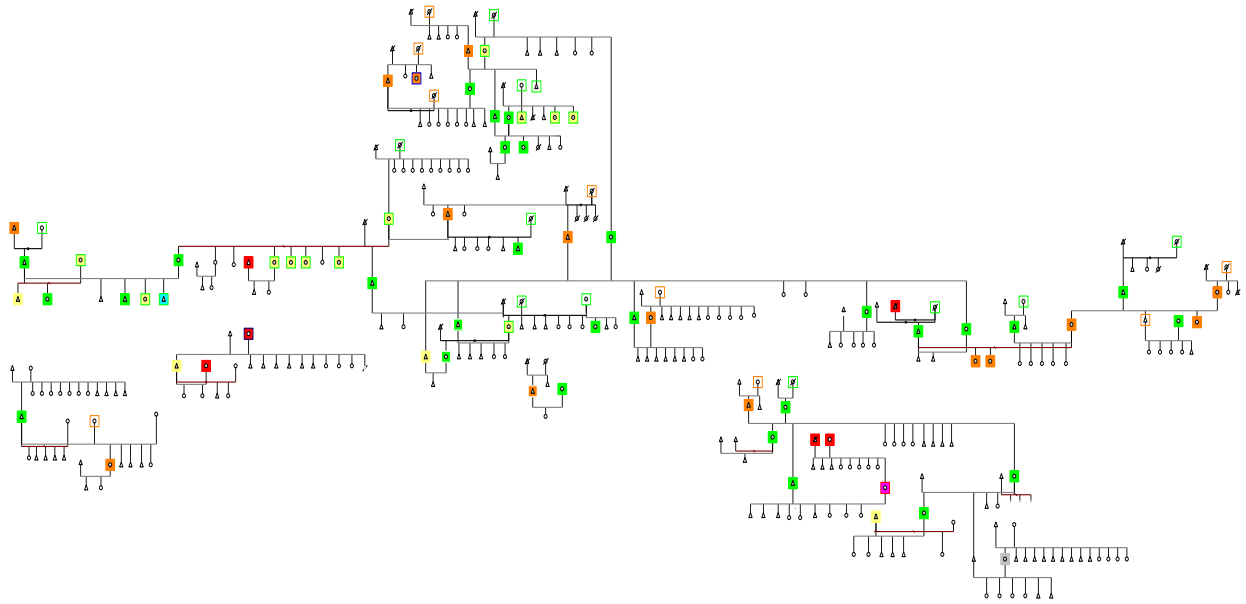

**Indian River:**

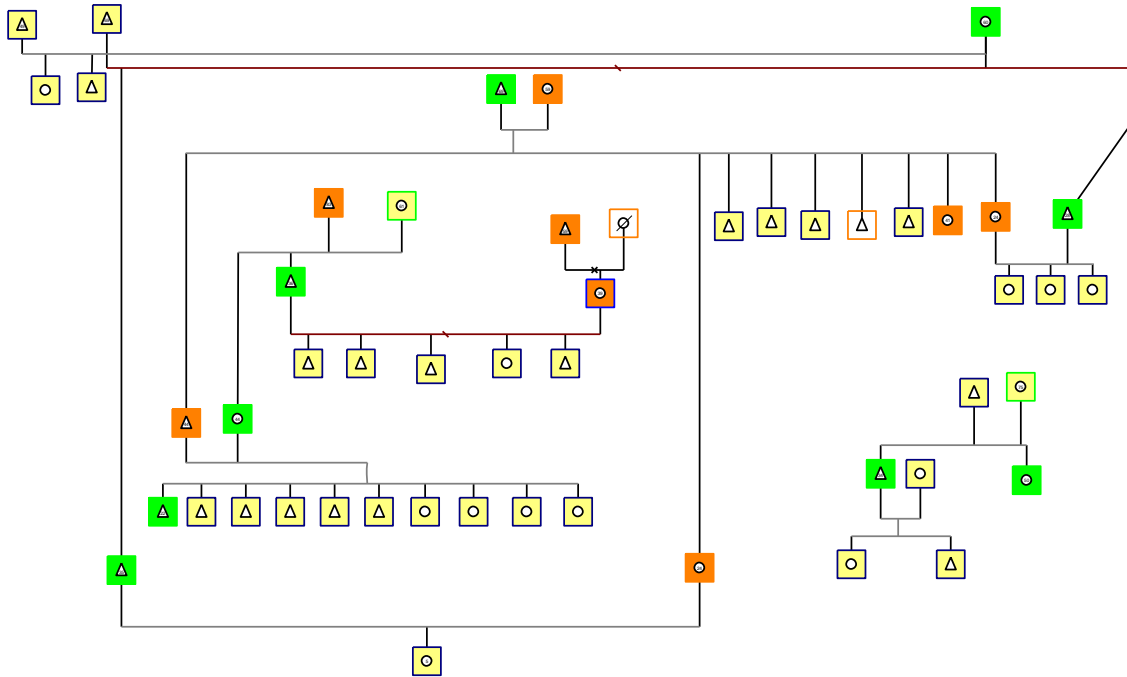



**Punta Aguila:**

